



PRECISION THIN SECTION,
SLEWING RING & CUSTOM
BEARING MANUFACTURER





Silverthin specializes in the engineering, manufacturing, sales and marketing of Thin Section and Slewing Ring (also known as Turntable) bearings. Our flexible manufacturing systems allow us to provide a wide variety of standard and custom bearing configurations across a broad range of sizes.

Silverthin manufactures large diameter, Thin Section ball bearings for space, aerospace, defense, industrial, robotic, semiconductor, medical, energy, distribution and other markets. Silverthin Thin Section bearings are manufactured in the United States in standard and custom configurations, sealed and unsealed, up to 37" in diameter. Components are stocked to meet customer short lead-time and customization requirements.

Silverthin Standard Slewing Ring bearings are manufactured in facilities located in Asia to Silverthin specifications with inspection and customer specific modifications performed in Preston, WA. We also manufacture USA Made slewing ring bearings for DFARS requirements upon customer requests. Standard and custom Slewing Ring bearings are engineered and manufactured up to 70 inches in diameter, some from special materials, to serve the needs of our diverse customer base.

The Silverthin Advantage:

- Experienced customer service representatives who provide fast, reliable, and friendly customer service.
- Flexible manufacturing and inventory management systems that offer among the industry's best lead times.
- Engineered products including standard, modified standard, and custom designs to meet specific application requirements.
- Complete application, product, and manufacturing engineering support.



ISO9001:2015

Silverthin
Mechatronics Corporation
Copyright 2026
05-08-26

Warranty, Errors & Omissions

Silverthin™ of Mechatronics, Corporation assumes no responsibility for errors or omissions in this catalog. Silverthin™ reserves the right to change information or specifications without notice. Application and use of this product is the sole responsibility of the user, however our engineering personnel will advise you of guidelines for the proper parameters of use of the product. Silverthin™ warrants the product to be free from defects in materials and workmanship only. Sellers only obligation hereunder is to either repair or replace the defective product or work within 12 months of product delivery to our customers. No other warranties are expressed or implied in fact or by law. Silverthin™ is not liable for associated costs of work done by the buyer involving our product, or altered product.

Our Quality Policy:

Our Quality Policy focuses on increasing customer satisfaction through:

- Strategic management of our corporation
- Consistently meeting customer requirements
- Continuous improvement of our processes
- The management and employees of Silverthin are committed to meeting customer requirements and expectations.
- We want to assure our customers that we have a Quality Management System capable of providing quality products and services on time.

ISO Registration Information:

- Silverthin is an ISO 9001 certified manufacturer of Thin Section and Slewing Ring bearings, Silverthin Quality Management System is certified to the ISO 9001 standard.
- A copy of our quality registration is available on request and our quality and manufacturing systems can be open to audit by our customers upon request and approval.



Office Location:

- 8152 304th Ave. SE, PO Box 5012, Preston, WA 98050-5012 USA



THIN SECTION BEARINGS	PAGE NUMBER
OVERVIEW & SELECTION GUIDE	<i>Clickable Page #</i>
What is a Thin Section Bearing and How does it Reduce Cost?	6
Industries and Applications	7-15
Selection Guide	16-19
Inch Series Dimensions & Size Range	20
Inch Series Part Numbering System	21
Metric Series Dimensions & Size Range	22
Metric Series Part Numbering System	23
Datasheet Generator	24
DIMENSIONAL TABLES	
Inch Series Open	
Angular Contact - Type A	26-32
Radial Contact - Type C	33-39
4-Point Contact - Type X	40-46
Inch Series Sealed or Shielded	
Radial Contact - Type C	47-50
4-Point Contact - Type X	51-54
Inch Series Duplex	
Back-to-Back - Type B	55-61
Face-to-Face - Type F	62-68
Tandem - Type T	70-76
Metric Series Open	
Angular Contact - Type A	78-80
Radial Contact - Type C	81-83
4-Point Contact - Type X	84-86
Metric Extra Thin	87-89
Metric Series Duplex	
Back-to-Back - Type B	90-92
Face-to-Face - Type F	93-95
Tandem - Type T	96-98
OPTIONS	
Integral Bearing Closures - Seals and Shields	100
Stainless Steel (AISI 440C)	101
Other Materials	101
Specialty Coated Bearings	101
Hybrid Bearings (Ceramic Balls Si3N4)	102
SuperDuplex Thin Section Bearings	102
Custom Bearings & Assemblies	103
Support & Design Services	104

THIN SECTION BEARINGS	PAGE NUMBER
ENGINEERING	<i>Clickable Page #</i>
Capacity and Life	
Dynamic Capacities	105
Dynamic Life - Analytical Approach	105
Dynamic Life - Published Capacity Approach	105
Static Capacities	105
Static Capacity and Static Safety Factor	105
Speeds	106
Precision Class & Runout	107
Precision Tolerances & Fits	108-113
Bearing Internal Clearance Relationship	114-115
Clearance and Preload (Internal Fits)	116
Width / Face Flushness	116
Minimum Load Requirements	117
Duplexing Options	118
Duplexing Markings and Orientation	119
Deflection and Stiffness	120-121
Rotation and Movement	122
Thermal Expansion	123-124
Torque and Resistance	125
Inspection & Mating Component Design	126
Installation, Shaft & Housing Interfaces, Shaft & Housing Fit	127
Lubrication	128
Separator Types	129
Special Widths	130
Special Application Considerations	
Space, Aerospace & Gimbals	131



Table of Contents

Slewing Ring Bearings



SLEWING RING BEARINGS	PAGE NUMBER
OVERVIEW & SELECTION GUIDE	<i>Clickable Page #</i>
Selection Guide	132-133
Datasheet Generator	25
DIMENSIONAL TABLES / CAPACITY TABLES	
Rectangular (No Gear/External Gear)	
Standard Capacity (STO-STE)	134-135
High Capacity (ST-X)	136-137
Flanged (No Gear/External Gear/Internal Gear)	
2 Mounting Flanges (SK6- P1Z)	139
1 Mounting Flange/Internal Gear (SK6- N1Z)	138
1 mounting Flange/External Gear (SK6- E1Z)	140
Load Curves	141-142
Mating Pinions & Gear Backlash	143-144
Custom Slewing Rings	145
SLEWING RING BEARINGS ENGINEERING	
Components	146
Service Factors	147
Typical Applications	148
Load Capability	148
Speed	148
Accuracy	148
Environment	148
Mounting Tension Versus Compression	148
Minimum Mounting Structure Guidelines	149
Flatness and Mounting Surface Dish	149
Allowable Deflection vs Raceway Diameter	149
Lubrication	150
Frictional Moment (Torque)	150
Bolts	150
Bolting Recommendations	151
Securing the Bearing	151
Warning Signs for Bearing Failure	151

SERVICES	PAGE NUMBER
SILVERTHIN SERVICES FOR THIN SECTION, SLEWING RING & CUSTOM BEARINGS	<i>Clickable Page #</i>
Bearing Lubrication & Relubrication	104
Bearing Analysis/Application Analysis	104
Custom Bearings or Assemblies	104
Bearing Modification	104
Special Widths	104
Pair Matching (Duplexing), Universal	104



What is a Thin Section Bearing and How does it Reduce Cost?

THIN SECTION bearings are a family of bearings designed from a limited number of widths and thicknesses (cross sections), with each cross section manufactured in a wide range of bore diameters. Most radial ball bearings are designed so that as the bore size increases, the width and the thickness of the bearing change proportionately. In the case of thin section bearings the cross section remains the same as the bore diameter increases. The thin section bearing family is made up of 9 primary cross section sets ranging from 3/16" to 1" and with bore sizes ranging from 1" to over 40". The combination of a large bore diameter in proportion to the small cross section makes these parts appear "thin" in comparison to standard ball bearings. Thin section bearings are made from 52100 chrome steel and 440C stainless steel. They can also be coated with platings like thin dense chrome. Some sizes can be configured with seals or shields. Thin section bearings are also made in one of three different contact styles; radial contact, angular contact, and four point contact. These options, along with several ball and retainer types make for a diverse range of parts even among the limited cross sections of the thin section bearing family.

Thin section bearings help reduce total cost in a system by allowing for design efficiency over standard bearing sizes. Because thin section bearings have cross sections that don't change as bore sizes increase, there needs to be no change in the space requirements, and little change in the weight of the bearing, even as the diameter of an application increases. Especially in the case of medical equipment, airborne optical and infrared scanning equipment, and robotics, the space and weight requirements of a system are major factors in the overall design and manufacturing cost. In many cases, the price of a thin section bearing is higher than a standard bearing with a similar bore size, but application and design savings due to reduced space and lower weight decrease the total cost in the application.



Space

Our Silverthin bearings play a critical role in advancing space exploration, supporting projects from Low Earth Orbit to Mars and beyond. With a lightweight, compact design, our bearings provide key advantages for spacecraft, where minimizing weight is essential. Our thin section and slewing ring bearings are integral to satellite systems, robotics, mechanical devices, communications, surveillance, tracking, and other functions, ensuring precise movement, low torque, load distribution, and vibration reduction. Engineered to endure the harsh conditions of space, these bearings deliver long-term reliability.

Additionally, our customization capabilities allow us to create tailored solutions that meet the unique demands of each mission, contributing to the success of space exploration initiatives.

Applications include:

- Spacecraft Mechanism
- Reaction Wheels
- Satellites
- Solar Array
- Multi-Axis Robotic Arm
- Rover
- Antenna System
- Scientific Instruments
- Navigation Gimbal
- Earth Observatory System
- Telescope
- New Product Development
- Harsh Environment
- Communications
- Internet
- Mobility



Aerospace & Defense

At Silverthin, precision and innovation drive the performance of every aerospace and defense bearing we manufacture. Our lightweight, compact designs are engineered to meet the stringent demands of aerospace, satellites, UAVs, and more, where every ounce matters. Whether in aircraft systems, spacecraft mechanisms, or weapons platforms, Silverthin's thin section bearings are at the core of each application, ensuring reliability and accuracy.

We specialize in custom bearing designs, offering specialty coatings, lubrications, and materials to withstand extreme conditions like high temperatures, vacuum, and radiation. From the Mars Rover to combat platforms on land, in the air, or at sea, our bearings are trusted in critical aerospace and defense applications. Our slewing ring bearings also enhance the precision of targeting systems, radar, and satellite installations.

With a commitment to partnership and legendary service, Silverthin is ready to support your mission with the precision and reliability needed to succeed in the most challenging conditions.

Applications include:

- Unmanned Aerial Vehicle (UAV)
- Gimbal
- Aerial Refueling Boom
- Guidance System
- Avionic Equipment
- Counter Measure System
- Radar/Sonar System
- Satellite Communication Installation
- Elevator and Arresters
- Target Acquisition & Tracking System
- Gun Barrel Mounts
- Turret & Weapons System
- Ground Combat/Security Vehicle
- Communication Satellites
- Antenna Pedestal
- Laser System
- Security & Surveillance



Robotics

At Silverthin, our thin section robotics bearings are essential to the precision, versatility, and compact design needed in today's evolving world of automation. From welding robots ensuring flawless joint movements to robotic end effectors handling both radial, axial and moment loads with low friction, our bearings deliver accuracy across industries—from industrial automation to space exploration and medical robotics.

In handling robots, Silverthin slewing ring bearings enable smooth, precise movements, ensuring smooth rotation and safety. For manufacturing robots, our bearings enhance productivity by supporting faster, more efficient operations. Our specialty thin section bearings have even contributed to numerous space exploration projects.

Silverthin is committed to providing high-performance bearing solutions, boosting productivity and ensuring seamless operation in robotics and automation.

Applications include:

- Multi-Axis Robotic Arm
- Vision System
- Handling Robot
- Pick and Place Robot
- Assembly Robot
- Welding Robot
- UV Sanitation Robot
- Tactical Robot
- Rover
- Space Platform Robot



Industrial Machinery

At Silverthin, we prioritize space optimization, weight reduction, and precise movement to enhance the performance of your industrial machinery. Our bearings are engineered for continuous, high-speed rotation and can be sealed to protect against contaminants, making them ideal for automation, packaging, textile manufacturing, agriculture, food processing, and more.

In automation systems, where precision and speed are critical, our thin section bearings ensure accuracy, enabling seamless coordination of robotic arms, conveyor systems, and material handling. In packaging, our bearings guarantee smooth and precise operations, safeguarding your products. In textile and food processing, they ensure uninterrupted, high-quality production.

From wastewater treatment to tire manufacturing, Silverthin bearings deliver efficiency, precision, and reliability. With Silverthin, you gain a partner committed to optimizing your machinery and driving future innovation.

Applications include:

- Automation Systems
- Packaging Equipment
- Pallet Wrapper
- Material Handling
- Indexing and Rotary Tables
- Bottling Equipment
- Food Production
- Spindle
- Textile Machinery
- Pipe Cutting and Bending Equipment
- Tire Manufacturing
- Conveyor System
- Waste Water Treatment



Medical

At Silverthin, we combine cutting-edge innovation with precision to advance medical systems. Our thin section bearings are used globally in critical devices such as centrifugal blood analyzers, prosthetics, X-ray technologies, diagnostic tools, and robotic surgeries. Designed for slow, intermittent and high-speed rotation sealed with medical-grade materials, our bearings ensure optimal performance in even the most demanding applications.

From enabling smooth, life-like movement in prosthetics to ensuring precise positioning in surgical robots, our thin section and slewing ring bearings enhance diagnostic tools and treatment equipment. In demanding fields like robotic surgery and oncology treatment, Silverthin bearings guarantee the accuracy and reliability necessary for patient care.

At Silverthin, we are committed to advancing healthcare through our precision-engineered bearings and dedicated engineering support, partnering with you to meet the highest demands of modern medical systems.

Applications include:

- Prosthetics/Artificial Limbs
- X-Ray Arm
- CT Scanner
- Diagnostic Equipment
- Oncology Treatment
- Robotic Surgery
- Centrifuge
- Scientific Instrument
- Therapeutics Manufacturing
- UV Sanitation Robot
- Microscope
- Medical Stair Lift
- Patient Assist Devices



Renewable Energy

Welcome to Silverthin, your partner in supporting a clean, more sustainable energy future. Our thin section bearings are integral to renewable energy sectors, including solar, wind, and hydropower. From turbine assemblies in hydropower equipment to ensuring precision in solar panel positioning mounts, we provide the reliability and efficiency needed for green energy applications.

In small wind turbines, our bearings capture the full potential of the breeze, while in solar energy, our slewing rings enable smooth, optimal positioning to maximize sunlight capture. We also enhance energy storage flywheels, ensuring efficient power release when needed.

At Silverthin, we are committed to elevating the renewable energy sector with innovative bearing solutions, helping you realize the full potential of every project.

Applications include:

- Energy Storage Flywheel
- Solar Panel Positioning Mounts
- Small Wind Turbine
- Gearbox
- Tidal Energy



Oil & Gas

At Silverthin, we combine engineering expertise with a deep understanding of the intricate demands of the Oil & Gas sector. Our thin section and slewing ring bearings are designed to excel in critical applications such as downhole and directional drilling, pipe inspections, riser connections, rig rotations, and blowout prevention, both on land and offshore.

In high-pressure, high-temperature environments, our bearings ensure the reliability and efficiency of downhole drilling units. From supporting accurate pipe inspections to enabling seamless rig rotation and load handling in top drive systems, Silverthin bearings are engineered for precision and durability. Our bearings also play a vital role in power swivels and blowout protectors, ensuring safety and fluid control during operations.

At Silverthin, we provide reliable bearing solutions tailored to meet the unique challenges of your Oil & Gas projects, driving success with every rotation.

Applications include:

- Downhole Drilling
- Harsh Environment
- Pipe Inspection
- Riser Connection
- Rotating Rig
- Blowout Protection
- Power Swivels
- Top Drive
- Crane
- Coil Tubing
- Mooring System
- Terminal Equipment



Heavy Equipment

Welcome to Silverthin, where resilience and precision drive the performance of heavy equipment. In industries powered by cranes, grapples, log loaders, and mining machinery, every component plays a critical role. Our slewing ring and thin section bearings are engineered to deliver smooth rotation, stability, and longevity in even the toughest environments.

From cranes lifting heavy loads with pinpoint accuracy to grapples handling timber with force, our bearings ensure seamless operation. In the mining industry, where durability is paramount, our bearings keep equipment running efficiently, minimizing downtime.

Silverthin bearings are designed to enhance the capabilities of your heavy equipment. Let's build a future of success together.

Applications include:

- Crane
- Grapple
- Log Loader
- Feller Head
- Mill Saw
- Excavator
- Mining
- Rail Car
- Material Elevator
- Rock Crusher
- Shears
- Harsh Environment
- Lifts
- Utility Vehicle
- Equipment Display
- Transportation



Semiconductor

At Silverthin, we support the fast-paced world of semiconductor manufacturing with precision-engineered thin section ball bearings. Our bearings play a critical role in semiconductor equipment, ensuring the precision, cleanliness, and reliability required for device fabrication.

From high-speed spindles in wafer dicing and cutting to the precise positioning of wafers and masks, our bearings deliver low friction and high rotational accuracy. In wafer transfer systems, our bearings enable delicate, precise movements down to the nanometer, while our slewing ring bearings power pick-and-place robotic arms for seamless production.

Silverthin's specialty-coated bearings enhance vacuum deposition and etching systems, and our bearings ensure the reliability of inspection, cleaning, and polishing equipment. We fulfill performance needs for extreme temperature, pressures, chemical exposure and other critical performance and operational requirements. We are committed to elevating semiconductor manufacturing with our high-performance bearings and dedicated support.

Applications include:

- Wafer Transfer
- Probes
- Positioners
- Vacuum Deposition
- Pick and Place Robotic Arm
- Inspection
- Etching
- Measurement
- Robots
- Sonic Cleaning
- Mechanical Polishers

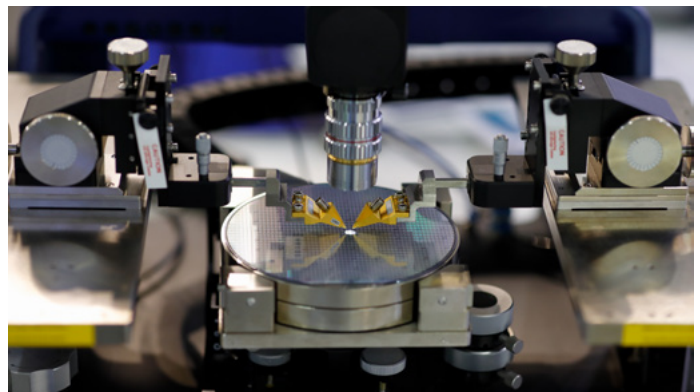

Angular Contact Bearings

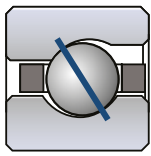

TYPE A

In applications with predominant axial loads the Type A, angular contact ball bearing should be used. This bearing also works well in radial or combined radial-thrust applications. The Type A bearing should never be used alone to support moment loads or reversing axial loading.

BEARING TYPE	LOAD CONDITION				
	RADIAL	AXIAL	MOMENT	REVERSING AXIAL	COMBINED RADIAL-THRUST
Type A Angular	Good	Excellent	Excellent Use in Pairs	Excellent Use in Pairs	Good
Type B Back-to-Back Pair	Very Good	Very Good	Very Good	Very Good	Good
Type F Face-to-Face Pair	Very Good	Very Good	Very Good	Very Good	Good
Type T Tandem Pair	Very Good	Excellent	Very Good	Very Good	Good
Type SB Single Outer Ring & Inner Ring Pair	Excellent	Excellent	Excellent	Excellent	Excellent
Type SF Outer Ring Pair & Single Inner Ring	Excellent	Excellent	Excellent	Excellent	Excellent

Two Type A bearings are often used as duplex pairs. Multiple configurations are available for duplex and superduplex. See Type B, Type F, Type T, Type SB and Type SF below for reference. Contact Silverthin Engineering for additional standard and custom configuration options for angular contact Type A thin section bearings.

Type B – Duplex Pair Back-to-Back

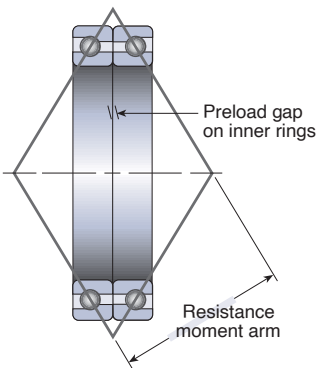

The B-Type thin section bearings are a back-to-back pair matched set using two Type A angular contact bearings that are arranged back-to-back with load lines diverging from the bearing axis. Because the Type A as a single bearing can only take axial (thrust) load in one direction, and no moment loads they are typically used in a pair matched arrangement. When they are pair matched, they can accommodate axial loading in both directions and moment loads.

Type F – Duplex Pair Face-to-Face

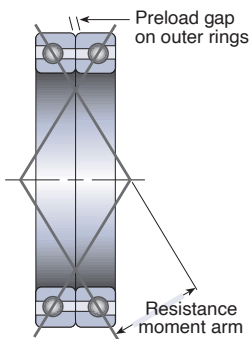

The F-Type thin section bearings are a face-to-face pair matched set using two Type A angular contact bearings that are arranged face-to-face with the load lines converging towards the bearing axis. Because the Type A as a single bearing can only take axial (thrust) load in one direction, and no moment loads they are typically used in a pair matched arrangement. When they are pair matched, they can accommodate axial loading in both directions and moment loads.

Angular Contact Bearings Continued

Type T – Duplex Pair Tandem

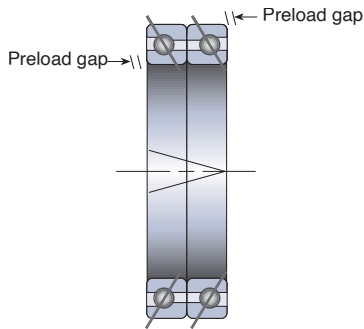

The T-Type thin section bearings are a tandem mounted pair matched set using two Type A angular contact bearings that can accept a very high axial load in one direction only. This is different from the back-to-back and face-to-face pair matched bearings, that can accommodate axial loading in both directions.

Type SB – SuperDuplex Single Outer Ring & Inner Ring Pair

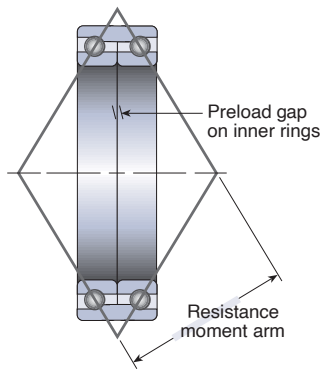

Single outer ring with inner ring matched pairs. Similar performance to a Type B Duplex Pair Back-to-Back, but in a single bearing for ease of assembly. Contact Silverthin engineering for additional Type SB SuperDuplex bearing information or request access to the Datasheet Generator.

Type SF – SuperDuplex Outer Ring Pair & Single Inner Ring

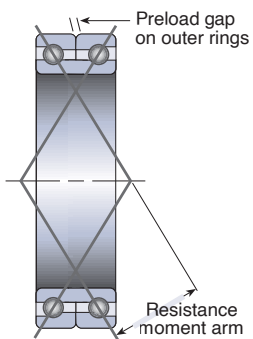

Single inner ring with outer ring matched pairs. Similar performance to a Type F Duplex Pair Face-to-Face, but in a single bearing for ease of assembly. Contact Silverthin engineering for additional Type SF SuperDuplex bearing information or request access to the Datasheet Generator.

Radial Contact Bearings Open

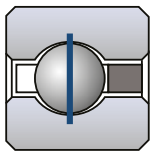

C - TYPE

LOAD CONDITION				
RADIAL	AXIAL	MOMENT	REVERSING AXIAL	COMBINED RADIAL-THRUST
Excellent	Good	Good (light to moderate loads)	Good (light to moderate loads)	Good

The Type C, radial contact ball bearing is designed with deep ball grooves to withstand high loads. Although this bearing is used primarily in applications with radial loads, it can withstand moderate axial loads, reversing axial loads, and moment loads.

Please contact Silverthin for radial bearing use with combined radial loads, with axial or moment loading, and for limiting speeds and separator selection.

Radial Contact Sealed or Shielded Bearings

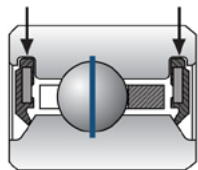

C - TYPE SEALED OR SHIELDED

The Sealed or Shielded Type C contact ball bearing has radial contact, meaning it primarily supports loads that acts perpendicular to the axis of rotation. Additionally, they are equipped with either seals or shields to provide some level of protection against contaminants, while allowing for smooth rotation.

A seal is typically made of rubber or other materials. Sealed bearings are more suitable for applications where the primary concern is preventing contaminants such as dust, dirt, and moisture from entering the bearing. A shield is typically made of metal. Shielded bearings are more suitable for applications where the primary concern is larger debris or particles rather than fine contaminants.

4-Point Contact Bearings

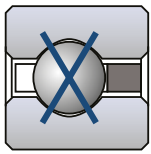

X - TYPE

LOAD CONDITION				
RADIAL	AXIAL	MOMENT	REVERSING AXIAL	COMBINED RADIAL-THRUST
Poor	Good	Excellent	Excellent	Poor

The Type X, or 4-point contact ball bearing is ideal for moment loading. Type X bearings are designed with gothic arch raceways creating 4 contact points between the balls and the raceways. This design is excellent for moment loading and reversing axial loading. The Type X bearing can be used for other light loading conditions, but is not recommended in place of the Type C or Type A bearing for pure radial or axial loads. In many cases a single Type X bearing can be used in place of multiple bearings in some cases, simplifying designs.

The Type X bearing has a slower speed capability than similar sized Type C and Type A duplex bearings. Also, this bearing comes standard with internal clearance unless specified otherwise. This means that a bearing with standard clearance will exhibit radial, axial and moment movement unless a preload is specified.

4-Point Contact Sealed or Shielded Bearings

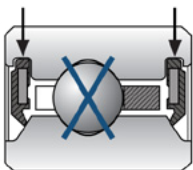

X - TYPE SEALED OR SHIELDED

The Sealed or Shielded Type X contact ball bearing or 4-point contact ball bearing is ideal for moment loading. Type X bearings are designed with gothic arch raceways creating 4 contact points between the balls and the raceways. Additionally, they are equipped with either seals or shields to provide some level of protection against contaminants, while allowing for smooth rotation. This design is excellent for moment loading and reversing axial loading. The Type X bearing can be used for other light loading conditions, but is not recommended in place of the C- or Type A bearing for pure radial loads.

A seal is typically made of rubber or other materials. Sealed bearings are more suitable for applications where the primary concern is preventing contaminants such as dust, dirt, and moisture from entering the bearing. A shield is typically made of metal. Shielded bearings are more suitable for applications where the primary concern is larger debris or particles rather than fine contaminants.

Thin Section Bearings

Inch Series Dimensions & Size Range



STANDARD PART NUMBER		TYPE		BORE DIAMETER (Inches)																													
OPEN BEARINGS	SAA 3/16" x 3/16" (.187 x .187)	 	A	1	1 1/2	1 3/4																											
			C	○	○	○																											
			X	○	○	○																											
	SA 1/4" x 1/4" (.250 x .250)	 	A				2	2 1/2	3	3 1/2	4	4 1/4	4 1/2	4 3/4	5	5 1/2	6	6 1/2	7	7 1/2	8	9	10	11	12								
			C	○	○	○	○	○	○	○	○	○	○	○	○	○	○	○	○	○	○	○	○	○	○	○	○	○	○	○	○		
			X	○	○	○	○	○	○	○	○	○	○	○	○	○	○	○	○	○	○	○	○	○	○	○	○	○	○	○	○		
	SB 5/16" x 5/16" (.3125 x .3125)	 	A																														
C			○	○	○	○	○	○	○	○	○	○	○	○	○	○	○	○	○	○	○	○	○	○	○	○	○	○	○	○			
X			○	○	○	○	○	○	○	○	○	○	○	○	○	○	○	○	○	○	○	○	○	○	○	○	○	○	○	○			
SC 3/8" x 3/8" (.375 x .375)	 	A									4	4 1/4	4 1/2	4 3/4	5	5 1/2	6	6 1/2	7	7 1/2	8	9	10	11	12	14	16	18	20	25	30		
		C	○	○	○	○	○	○	○	○	○	○	○	○	○	○	○	○	○	○	○	○	○	○	○	○	○	○	○	○	○		
		X	○	○	○	○	○	○	○	○	○	○	○	○	○	○	○	○	○	○	○	○	○	○	○	○	○	○	○	○	○		
SD 1/2" x 1/2" (.50 x .50)	 	A									4	4 1/4	4 1/2	4 3/4	5	5 1/2	6	6 1/2	7	7 1/2	8	9	10	11	12	14	16	18	20	25	30		
		C	○	○	○	○	○	○	○	○	○	○	○	○	○	○	○	○	○	○	○	○	○	○	○	○	○	○	○	○	○		
		X	○	○	○	○	○	○	○	○	○	○	○	○	○	○	○	○	○	○	○	○	○	○	○	○	○	○	○	○	○		
SF 3/4" x 3/4" (.75 x .75)	 	A									4	4 1/4	4 1/2	4 3/4	5	5 1/2	6	6 1/2	7	7 1/2	8	9	10	11	12	14	16	18	20	25	30	35	
		C	○	○	○	○	○	○	○	○	○	○	○	○	○	○	○	○	○	○	○	○	○	○	○	○	○	○	○	○	○	○	○
		X	○	○	○	○	○	○	○	○	○	○	○	○	○	○	○	○	○	○	○	○	○	○	○	○	○	○	○	○	○	○	○
SG 1" x 1" (1.0 x 1.0)	 	A									4	4 1/4	4 1/2	4 3/4	5	5 1/2	6	6 1/2	7	7 1/2	8	9	10	11	12	14	16	18	20	25	30	35	
		C	○	○	○	○	○	○	○	○	○	○	○	○	○	○	○	○	○	○	○	○	○	○	○	○	○	○	○	○	○	○	○
		X	○	○	○	○	○	○	○	○	○	○	○	○	○	○	○	○	○	○	○	○	○	○	○	○	○	○	○	○	○	○	○
SEALED / SHIELDED BEARINGS	JSHA 1/4" x 3/16" (.250 x .1875)	 	C	1	1 1/2	1 3/4																											
			X	○	○	○																											
	JSA 1/4" x 1/4" (.250 x .250)	 	C				2	2 1/2	3	3 1/2	4	4 1/4	4 1/2	4 3/4	5	5 1/2	6	6 1/2	7	7 1/2													
			X	○	○	○	○	○	○	○	○	○	○	○	○	○	○	○	○	○	○	○	○	○	○	○	○	○	○	○	○	○	○
JSB 5/16" x 5/16" (.3125 x .3125)	 	C				2	2 1/2	3	3 1/2	4	4 1/4	4 1/2	4 3/4	5	5 1/2	6	6 1/2																
		X	○	○	○	○	○	○	○	○	○	○	○	○	○	○	○	○	○	○	○	○	○	○	○	○	○	○	○	○	○	○	
JSU 1/2" x 3/8" (.50 x .375)	 	C									4	4 1/4	4 1/2	4 3/4	5	5 1/2	6	6 1/2	7	7 1/2	8	9	10	11	12								
		X	○	○	○	○	○	○	○	○	○	○	○	○	○	○	○	○	○	○	○	○	○	○	○	○	○	○	○	○	○	○	
CUSTOM BEARINGS	Standard and Special Large Diameter Unsealed and Sealed Silverthin Bearings are available upon request. These bearings are available in a variety of cross sections to meet customer needs. Email your request to us and we will advise availability or help with your special application requirements. Call us at 1-866-294-5841 or email sales@silverthin.com																																

EXAMPLE PART NUMBER:

S A 0 2 5 X P 0

SEALS & SHIELDS



Blank = No Seal/Shield

J = Buna N Rubber Seal

JN = Non-Contact Buna N Shield

EN = Non-Contact 303SS Shield

B = PTFE Coated Fiberglass Seal

Seals available on certain sizes for C and X Types. Shields and Teflon seals are possible. Contact Silverthin Engineering.

COATING

Blank = No Coating

A = Nodular Thin Dense Chrome

NTDC plate tolerances, housing and shaft fits will change. Contact Silverthin Engineering. See Speciality Coated Bearing Page 101

SILVERTHIN = S

BASE MATERIAL

Blank = AISI 52100 Steel

S = 440C Stainless Steel

Other materials available upon request.

SERIES SECTION CODE (width cross section)

AA 3/16" x 3/16"
(.1875 x .1875)

HA 1/4" x 3/16"
(.250 x .1875)

Available in sealed version

A 1/4" x 1/4"
(.250 x .250)

Available in sealed version

B 5/16" x 5/16"
(.3125 x .3125)

Available in sealed version

C 3/8" x 3/8"
(.375 x .375)

U 1/2" x 3/8"
(.50 x .375)

D 1/2" x 1/2"
(.50 x .50)

F 3/4" x 3/4"
(.75 x .75)

G 1" x 1"
(1.0 x 1.0)

BORE SIZE IN INCHES X 10

Example:

2.50 X 10 = 025

7.00 X 10 = 070

TYPE

A Angular Contact

B Duplexed Back to Back

F Duplexed Face to Face

T Duplexed Tandem

C Radial Contact

X 4 Point Contact

SB SuperDuplexed Back to Back

SF SuperDuplexed Face to Face

INTERNAL FIT

Type C & X (unmounted)

A = .0000" to .0005" clearance

B = .0000" to .0010" clearance

C = .0005" to .0010" clearance

D = .0005" to .0015" clearance

E = .0010" to .0020" clearance

F = .0015" to .0025" clearance

G = .0020" to .0030" clearance

H = .0030" to .0040" clearance

I = .0040" to .0050" clearance

J = .0050" to .0060" clearance

K = .0000" to .0005" preload

L = .0000" to .0010" preload

M = .0005" to .0010" preload

N = .0005" to .0015" preload

P = .0010" to .0020" preload

Z = Special Fits

• Diametral Preload or Clearance for Type X or C

• Axial Preload or Clearance for Duplexed Type A

Above internal bearing fits apply to unmounted bearings only. Contact Silverthin for installation fits on the above custom clearances and preloads.

PRECISION CLASS

0 = ABEC Class 1 (see pages 108 & 109)

3 = ABEC Class 3 (see page 110)

5 = ABEC Class 5 (see page 111)

For Other Classes Contact Silverthin

SEPARATOR



N = Nylon, segmented snapover C & X

P = Brass, snapover C & X

L = Nylon, one piece snapover C & X

D = Phenolic, one piece snapover C & X

T = Stainless steel, one piece snapover C & X



R = Brass, one piece circular pocket A

G = Nylon, circular pocket A

H = Phenolic, one piece circular pocket A

U = Stainless steel, one piece circular pocket A

F = Full complement, no retainer, filling slot required for for C & X



















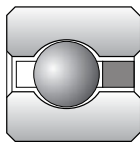





S = Spacer Balls, no retainer, filling slot required for for C & X

Z = Other

Thin Section Bearings

Metric Series Dimensions & Size Range

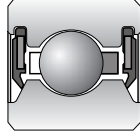

STANDARD PART NUMBER		TYPE	BORE DIAMETER (mm)																								
OPEN BEARINGS	SM08 8mm x 8mm 	 A  C  X	25	50	60	70	80	90	100	110	120	130	140	150	160	170	180	190	200	250	300	320	340	360			
			<input type="checkbox"/>	<input type="checkbox"/>	<input type="checkbox"/>	<input type="checkbox"/>	<input type="checkbox"/>	<input type="checkbox"/>	<input type="checkbox"/>	<input type="checkbox"/>	<input type="checkbox"/>	<input type="checkbox"/>	<input type="checkbox"/>	<input type="checkbox"/>	<input type="checkbox"/>	<input type="checkbox"/>	<input type="checkbox"/>	<input type="checkbox"/>	<input type="checkbox"/>	<input type="checkbox"/>	<input type="checkbox"/>	<input type="checkbox"/>	<input type="checkbox"/>	<input type="checkbox"/>	<input type="checkbox"/>	<input type="checkbox"/>	
			<input type="checkbox"/>	<input type="checkbox"/>	<input type="checkbox"/>	<input type="checkbox"/>	<input type="checkbox"/>	<input type="checkbox"/>	<input type="checkbox"/>	<input type="checkbox"/>	<input type="checkbox"/>	<input type="checkbox"/>	<input type="checkbox"/>	<input type="checkbox"/>	<input type="checkbox"/>	<input type="checkbox"/>	<input type="checkbox"/>	<input type="checkbox"/>	<input type="checkbox"/>	<input type="checkbox"/>	<input type="checkbox"/>	<input type="checkbox"/>	<input type="checkbox"/>	<input type="checkbox"/>	<input type="checkbox"/>	<input type="checkbox"/>	<input type="checkbox"/>
OPEN BEARINGS	SM13 13mm x 13mm 	 A  C  X					80	90	100	110	120	130	140	150	160	170	180	190	200	250	300	320	340	360			
			<input type="checkbox"/>	<input type="checkbox"/>	<input type="checkbox"/>	<input type="checkbox"/>	<input type="checkbox"/>	<input type="checkbox"/>	<input type="checkbox"/>	<input type="checkbox"/>	<input type="checkbox"/>	<input type="checkbox"/>	<input type="checkbox"/>	<input type="checkbox"/>	<input type="checkbox"/>	<input type="checkbox"/>	<input type="checkbox"/>	<input type="checkbox"/>	<input type="checkbox"/>	<input type="checkbox"/>	<input type="checkbox"/>	<input type="checkbox"/>	<input type="checkbox"/>	<input type="checkbox"/>	<input type="checkbox"/>	<input type="checkbox"/>	
			<input type="checkbox"/>	<input type="checkbox"/>	<input type="checkbox"/>	<input type="checkbox"/>	<input type="checkbox"/>	<input type="checkbox"/>	<input type="checkbox"/>	<input type="checkbox"/>	<input type="checkbox"/>	<input type="checkbox"/>	<input type="checkbox"/>	<input type="checkbox"/>	<input type="checkbox"/>	<input type="checkbox"/>	<input type="checkbox"/>	<input type="checkbox"/>	<input type="checkbox"/>	<input type="checkbox"/>	<input type="checkbox"/>	<input type="checkbox"/>	<input type="checkbox"/>	<input type="checkbox"/>	<input type="checkbox"/>	<input type="checkbox"/>	<input type="checkbox"/>
OPEN BEARINGS	SM20 20mm x 20mm 	 A  C  X									110	120	130	140	150	160	170	180	190	200	250	300	320	340	360		
			<input type="checkbox"/>	<input type="checkbox"/>	<input type="checkbox"/>	<input type="checkbox"/>	<input type="checkbox"/>	<input type="checkbox"/>	<input type="checkbox"/>	<input type="checkbox"/>	<input type="checkbox"/>	<input type="checkbox"/>	<input type="checkbox"/>	<input type="checkbox"/>	<input type="checkbox"/>	<input type="checkbox"/>	<input type="checkbox"/>	<input type="checkbox"/>	<input type="checkbox"/>	<input type="checkbox"/>	<input type="checkbox"/>	<input type="checkbox"/>	<input type="checkbox"/>	<input type="checkbox"/>	<input type="checkbox"/>	<input type="checkbox"/>	<input type="checkbox"/>
			<input type="checkbox"/>	<input type="checkbox"/>	<input type="checkbox"/>	<input type="checkbox"/>	<input type="checkbox"/>	<input type="checkbox"/>	<input type="checkbox"/>	<input type="checkbox"/>	<input type="checkbox"/>	<input type="checkbox"/>	<input type="checkbox"/>	<input type="checkbox"/>	<input type="checkbox"/>	<input type="checkbox"/>	<input type="checkbox"/>	<input type="checkbox"/>	<input type="checkbox"/>	<input type="checkbox"/>	<input type="checkbox"/>	<input type="checkbox"/>	<input type="checkbox"/>	<input type="checkbox"/>	<input type="checkbox"/>	<input type="checkbox"/>	<input type="checkbox"/>
OPEN EXTRA THIN BEARINGS	SSM03 2.5mm x 3mm <i>Base Material Requires 440C Stainless Steel</i>	  A  C  X	35	60	70	74	80	90	100																		
			<input type="checkbox"/>	<input type="checkbox"/>	<input type="checkbox"/>	<input type="checkbox"/>	<input type="checkbox"/>	<input type="checkbox"/>	<input type="checkbox"/>	<input type="checkbox"/>	<input type="checkbox"/>	<input type="checkbox"/>	<input type="checkbox"/>	<input type="checkbox"/>	<input type="checkbox"/>	<input type="checkbox"/>	<input type="checkbox"/>	<input type="checkbox"/>	<input type="checkbox"/>	<input type="checkbox"/>	<input type="checkbox"/>	<input type="checkbox"/>	<input type="checkbox"/>	<input type="checkbox"/>	<input type="checkbox"/>		
			<input type="checkbox"/>	<input type="checkbox"/>	<input type="checkbox"/>	<input type="checkbox"/>	<input type="checkbox"/>	<input type="checkbox"/>	<input type="checkbox"/>	<input type="checkbox"/>	<input type="checkbox"/>	<input type="checkbox"/>	<input type="checkbox"/>	<input type="checkbox"/>	<input type="checkbox"/>	<input type="checkbox"/>	<input type="checkbox"/>	<input type="checkbox"/>	<input type="checkbox"/>	<input type="checkbox"/>	<input type="checkbox"/>	<input type="checkbox"/>	<input type="checkbox"/>	<input type="checkbox"/>	<input type="checkbox"/>		
SEALED / SHIELDED BEARINGS	JSM08 8mm x 8mm 	 C  X	25	50	60	70	80	90	100	110	120	130	140	150	160	170	180	190	200	250	300	320	340	360			
			<input type="checkbox"/>	<input type="checkbox"/>	<input type="checkbox"/>	<input type="checkbox"/>	<input type="checkbox"/>	<input type="checkbox"/>	<input type="checkbox"/>	<input type="checkbox"/>	<input type="checkbox"/>	<input type="checkbox"/>	<input type="checkbox"/>	<input type="checkbox"/>	<input type="checkbox"/>	<input type="checkbox"/>	<input type="checkbox"/>	<input type="checkbox"/>	<input type="checkbox"/>	<input type="checkbox"/>	<input type="checkbox"/>	<input type="checkbox"/>	<input type="checkbox"/>	<input type="checkbox"/>	<input type="checkbox"/>	<input type="checkbox"/>	
			<input type="checkbox"/>	<input type="checkbox"/>	<input type="checkbox"/>	<input type="checkbox"/>	<input type="checkbox"/>	<input type="checkbox"/>	<input type="checkbox"/>	<input type="checkbox"/>	<input type="checkbox"/>	<input type="checkbox"/>	<input type="checkbox"/>	<input type="checkbox"/>	<input type="checkbox"/>	<input type="checkbox"/>	<input type="checkbox"/>	<input type="checkbox"/>	<input type="checkbox"/>	<input type="checkbox"/>	<input type="checkbox"/>	<input type="checkbox"/>	<input type="checkbox"/>	<input type="checkbox"/>	<input type="checkbox"/>	<input type="checkbox"/>	<input type="checkbox"/>
SEALED / SHIELDED BEARINGS	JSM13 13mm x 13mm 	 C  X					80	90	100	110	120	130	140	150	160	170	180	190	200	250	300	320	340	360			
			<input type="checkbox"/>	<input type="checkbox"/>	<input type="checkbox"/>	<input type="checkbox"/>	<input type="checkbox"/>	<input type="checkbox"/>	<input type="checkbox"/>	<input type="checkbox"/>	<input type="checkbox"/>	<input type="checkbox"/>	<input type="checkbox"/>	<input type="checkbox"/>	<input type="checkbox"/>	<input type="checkbox"/>	<input type="checkbox"/>	<input type="checkbox"/>	<input type="checkbox"/>	<input type="checkbox"/>	<input type="checkbox"/>	<input type="checkbox"/>	<input type="checkbox"/>	<input type="checkbox"/>	<input type="checkbox"/>	<input type="checkbox"/>	
			<input type="checkbox"/>	<input type="checkbox"/>	<input type="checkbox"/>	<input type="checkbox"/>	<input type="checkbox"/>	<input type="checkbox"/>	<input type="checkbox"/>	<input type="checkbox"/>	<input type="checkbox"/>	<input type="checkbox"/>	<input type="checkbox"/>	<input type="checkbox"/>	<input type="checkbox"/>	<input type="checkbox"/>	<input type="checkbox"/>	<input type="checkbox"/>	<input type="checkbox"/>	<input type="checkbox"/>	<input type="checkbox"/>	<input type="checkbox"/>	<input type="checkbox"/>	<input type="checkbox"/>	<input type="checkbox"/>	<input type="checkbox"/>	<input type="checkbox"/>
SEALED / SHIELDED BEARINGS	JSM20 20mm x 20mm 	 C  X									110	120	130	140	150	160	170	180	190	200	250	300	320	340	360		
			<input type="checkbox"/>	<input type="checkbox"/>	<input type="checkbox"/>	<input type="checkbox"/>	<input type="checkbox"/>	<input type="checkbox"/>	<input type="checkbox"/>	<input type="checkbox"/>	<input type="checkbox"/>	<input type="checkbox"/>	<input type="checkbox"/>	<input type="checkbox"/>	<input type="checkbox"/>	<input type="checkbox"/>	<input type="checkbox"/>	<input type="checkbox"/>	<input type="checkbox"/>	<input type="checkbox"/>	<input type="checkbox"/>	<input type="checkbox"/>	<input type="checkbox"/>	<input type="checkbox"/>	<input type="checkbox"/>	<input type="checkbox"/>	<input type="checkbox"/>
			<input type="checkbox"/>	<input type="checkbox"/>	<input type="checkbox"/>	<input type="checkbox"/>	<input type="checkbox"/>	<input type="checkbox"/>	<input type="checkbox"/>	<input type="checkbox"/>	<input type="checkbox"/>	<input type="checkbox"/>	<input type="checkbox"/>	<input type="checkbox"/>	<input type="checkbox"/>	<input type="checkbox"/>	<input type="checkbox"/>	<input type="checkbox"/>	<input type="checkbox"/>	<input type="checkbox"/>	<input type="checkbox"/>	<input type="checkbox"/>	<input type="checkbox"/>	<input type="checkbox"/>	<input type="checkbox"/>	<input type="checkbox"/>	<input type="checkbox"/>
CUSTOM BEARINGS	Standard and Special Large Diameter Unsealed and Sealed Silverthin Bearings are available upon request. These bearings are available in a variety of cross sections to meet customer needs. Email your request to us and we will advise availability or help with your special application requirements. Call us at 1-866-294-5841 or email sales@silverthin.com																										

EXAMPLE PART NUMBER: S M 1 5 0 0 8 X P 0

SEALS & SHIELDS



- Blank = No Seal/Shield
- J = Buna N Rubber Seal
- JN = Non-Contact Buna N Shield
- EN = Non-Contact 303SS Shield
- B = PTFE Coated Fiberglass Seal

Seals available on certain sizes for C and X Types. Shields and Teflon seals are possible. Contact Silverthin Engineering.

COATING

- Blank = No Coating
- A = Nodular Thin Dense Chrome

NTDC plate tolerances, housing and shaft fits will change. Contact Silverthin Engineering. See Speciality Coated Bearing Page 101

BASE MATERIAL

- Blank = AISI 52100 Steel
- S = 440C Stainless Steel

Other materials available upon request.

SILVERTHIN = SM

BORE SIZE IN MM

- Example:
- 150mm = 150
 - 25mm = 025

SERIES SECTION CODE

(width cross section)

Standard

08 8mm x 8mm

13 13mm x 13mm

20 20mm x 20mm

Extra Thin

(Base Material Requires 440C Stainless Steel)

03 2.5mm x 3mm

TYPE

- | | |
|--------------------------|--------------------------------|
| A Angular Contact | B Duplexed Back to Back |
| C Radial Contact | F Duplexed Face to Face |
| X 4 Point Contact | T Duplexed Tandem |

INTERNAL FIT (Inches)

Type C & X (unmounted)

- A = .0000" to .0005" clearance
- B = .0000" to .0010" clearance
- C = .0005" to .0010" clearance
- D = .0005" to .0015" clearance
- E = .0010" to .0020" clearance
- F = .0015" to .0025" clearance
- G = .0020" to .0030" clearance
- H = .0030" to .0040" clearance
- I = .0040" to .0050" clearance
- J = .0050" to .0060" clearance
- K = .0000" to .0005" preload
- L = .0000" to .0010" preload
- M = .0005" to .0010" preload
- N = .0005" to .0015" preload
- P = .0010" to .0020" preload
- Z = Special Fits

- Diametral Preload or Clearance for Type X or C
- Axial Preload or Clearance for Duplexed Type A

Above internal bearing fits apply to unmounted bearings only. Contact Silverthin for installation fits on the above custom clearances and preloads.

PRECISION CLASS

- O = ABEC Class 1 (see pages 112 & 113)

For Other Classes Contact Silverthin

SEPARATOR



- N** = Nylon, segmented snapover C & X
- P** = Brass, snapover C & X
- L** = Nylon, one piece snapover C & X
- D** = Phenolic, one piece snapover C & X
- T** = Stainless steel, one piece snapover C & X



- R** = Brass, one piece circular pocket A
- G** = Nylon, circular pocket A
- H** = Phenolic, one piece circular pocket A
- U** = Stainless steel, one piece circular pocket A



- F** = Full complement, no retainer, filling slot required for C & X
- S** = Spacer Balls, no retainer, filling slot required for C & X
- Z** = Other



Silverthin Datasheet Generator

The Silverthin Datasheet Generator is a useful reference for thin section and slewing ring bearing dimensional information, loading capacities, and speed ratings. Generate a custom datasheet specific to any part number with any combinations of options or modifications.

Thin Section Bearing example shown below:

Datasheet information includes:

- Part numbering system breakdown
- Support for standard inch and metric part numbers
- Dimensions and tolerances
- Static and Dynamic Load Ratings
- Speed Ratings and Grease Calculations
- Temperature Limits
- Recommended Fits table for mating parts
- Component materials
- 3D Modeling
- Other languages available

Access to the datasheet generator is available by contacting Silverthin directly or by contacting one of our Exclusive Distributors. Request your access key today at:

www.silverthin.com/contact/datasheet-access/

Technical Data Sheet

SC070XP0

BEARING DETAILS	
All dimensions in inches	
Approximate Weight	0.73 lbs
Nominal Ball Size	Ø 0.1875
Ball Count	59
Inner Race Runout	0.0010
Outer Race Runout	0.0010
Temperature Range	-65 °F +250 °F
Radial Clearance	0.0020 0.0030
Axial Clearance	0.0031 0.0045

<p>USER NOTES</p>	<table border="1" style="width: 100%; border-collapse: collapse;"> <tr> <td style="width: 50%; text-align: center;">S</td> <td style="width: 50%; text-align: center;">C</td> </tr> <tr> <td style="text-align: center;">070</td> <td style="text-align: center;">XP0</td> </tr> <tr> <td style="text-align: center;">ABEC 1F</td> <td style="text-align: center;">BRASS SNAPOVER CAGE</td> </tr> <tr> <td style="text-align: center;">4 POINT CONTACT</td> <td style="text-align: center;">BORE SIZE IN INCHES X 10</td> </tr> </table>	S	C	070	XP0	ABEC 1F	BRASS SNAPOVER CAGE	4 POINT CONTACT	BORE SIZE IN INCHES X 10
S	C								
070	XP0								
ABEC 1F	BRASS SNAPOVER CAGE								
4 POINT CONTACT	BORE SIZE IN INCHES X 10								

LOAD RATINGS		
	STATIC	DYNAMIC
RADIAL	3,550 lbs	1,930 lbs
AXIAL	8,870 lbs	3,130 lbs
MOMENT	13,080 in-lbs	5,340 in-lbs

Capacities do not apply simultaneously, and are based on the separator. The static ratings are based on the onset of permanent non-detrimental deformation. The dynamic rating is based on the 1,000,000 revolutions L10 bearing life.

STANDARD RECOMMENDED FITS			
ROTATING SHAFT		STATIONARY SHAFT	
Ø SHAFT	Ø HOUSING	Ø SHAFT	Ø HOUSING
7.0000	7.7500	6.9990	7.7488
7.0010	7.7512	6.9980	7.7476

Tolerance recommendations for shaft & housing shown are only valid for steel bearings, shafts and housings at standard clearance and equalized temperatures.

For other conditions, please contact Silverthin Engineering at +1.866.294.5841 or Engineering@silverthin.com for assistance.

MAX SPEED VS LOAD

SILVERTHIN BEARING GROUP

<http://www.silverthin.com>
 +1 866.294.5841
 sales@silverthin.com
 @silverthin



KEY:

LOG IN

[REQUEST ACCESS KEY](#)



Datasheet Generator Additional Features:

- Switch between Imperial and Metric units easily
- Translation support between 10+ languages
- 3D model download support
- Competitor part number recognition

Slewing Ring example shown below:

Technical Data Sheet

STE-870T

SLEWING RING DETAILS	
All dimensions in inches	
Approximate Weight	771.0 lbs
Nominal Ball Size	Ø 2.0000
Ball Count	56
Temperature Range	-65 °F . . . +250 °F
Grease Fitting	1/8-27NPT
Lifting Eye	1 1/8-7UNC
Number of Teeth	117

STATIC LOAD LIMIT	
MOMENT (FT-LBS)	AXIAL LOAD (LBS)

PINION DETAILS		
	SP870-17	SP870-17
Tooth Form	SD	SD
Number of Teeth	17	17
Approximate Weight	46.2 lbs	46.2 lbs
Pressure Angle	20°	20°
Ø (D1)	6.800	6.800
Ø (Dr1)	5.510	5.510
Ø (Do1)	7.440	7.440

NORMALLY STOCKED INVENTORY

For more information, call SILVERTHIN at +1 866.294.5841. SILVERTHIN reserves the right to change specification and other information without notice.

SILVERTHIN BEARING GROUP

<http://www.silverthin.com>
 +1 866.294.5841
sales@silverthin.com
 @silverthin



Inch Open Type A

Angular Contact Bearings



In applications with predominant axial or moment loads, angular contact ball bearings are often the appropriate selection. These bearings work well in all loading conditions (radial, axial, moment and combined loads). Type-A bearings are typically used with 2 bearings at a minimum for most applications.

Two Type A bearings are often used as a duplex pair. Different configurations for duplex bearings are shown in the Engineering section of this catalog. Please contact Silverthin for application of these bearings.

LOAD CONDITION				
RADIAL	AXIAL	MOMENT	REVERSING AXIAL	COMBINED RADIAL-THRUST
Good	Excellent	Excellent (Use In Pairs)	Excellent (Use In Pairs)	Good

SAA SERIES 3/16" X 3/16"

SILVERTHIN PART NUMBER	DIMENSIONS IN INCHES					CAPACITIES IN POUNDS				APPROX WEIGHT POUNDS
	BORE DIAMETER "B"	OUTSIDE DIAMETER "D"	LAND DIAMETER "L1"	LAND DIAMETER "L2"	LAND DIAMETER "L3"	RADIAL		THRUST		
						STATIC	DYNAMIC	STATIC	DYNAMIC	
SAA10AGO	1.000	1.375	1.140	1.235	1.274	340	195	970	450	0.03
SAA15AGO	1.500	1.875	1.640	1.735	1.774	480	240	1,380	560	0.04
SAA17AGO	1.750	2.125	1.890	1.985	2.024	530	250	1,520	600	0.04

Nylon; circular pocket separator standard 3/32" balls

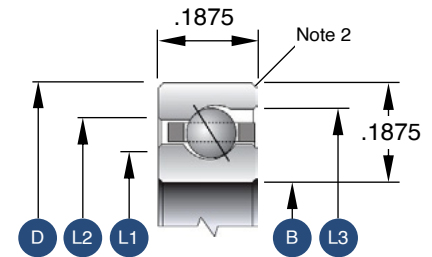

1. Load capacities are not additive
2. The maximum shaft or housing fillet radius that the bearing corners will clear for this series is 0.015"
3. Race Width Tolerance: +0.000-0.005"



SA SERIES 1/4" X 1/4"

SILVERTHIN PART NUMBER	DIMENSIONS IN INCHES					CAPACITIES IN POUNDS				APPROX WEIGHT POUNDS
	BORE DIAMETER "B"	OUTSIDE DIAMETER "D"	LAND DIAMETER "L1"	LAND DIAMETER "L2"	LAND DIAMETER "L3"	RADIAL		THRUST		
						STATIC	DYNAMIC	STATIC	DYNAMIC	
SA020ARO	2.000	2.500	2.186	2.314	2.369	790	405	2,280	960	0.10
SA025ARO	2.500	3.000	2.686	2.814	2.869	960	460	2,780	1,100	0.13
SA030ARO	3.000	3.500	3.186	3.314	3.367	1,140	505	3,290	1,230	0.15
SA035ARO	3.500	4.000	3.686	3.814	3.867	1,310	550	3,790	1,350	0.18
SA040ARO	4.000	4.500	4.186	4.314	4.367	1,490	595	4,300	1,470	0.19
SA042ARO	4.250	4.750	4.436	4.564	4.615	1,580	615	4,550	1,530	0.20
SA045ARO	4.500	5.000	4.686	4.814	4.865	1,660	635	4,810	1,580	0.22
SA047ARO	4.750	5.250	4.936	5.064	5.115	1,750	655	5,060	1,640	0.23
SA050ARO	5.000	5.500	5.186	5.314	5.365	1,840	675	5,310	1,690	0.24
SA055ARO	5.500	6.000	5.686	5.814	5.863	2,020	715	5,820	1,800	0.25
SA060ARO	6.000	6.500	6.186	6.314	6.363	2,190	750	6,320	1,900	0.28
SA065ARO	6.500	7.000	6.686	6.814	6.861	2,370	790	6,830	2,000	0.30
SA070ARO	7.000	7.500	7.186	7.314	7.361	2,540	825	7,340	2,100	0.31
SA075ARO	7.500	8.000	7.686	7.814	7.861	2,720	855	7,840	2,190	0.34
SA080ARO	8.000	8.500	8.186	8.314	8.359	2,890	890	8,350	2,280	0.38
SA090ARO	9.000	9.500	9.186	9.314	9.357	3,240	955	9,360	2,470	0.44
SA100ARO	10.000	10.500	10.186	10.314	10.355	3,590	1,015	10,370	2,640	0.50
SA110ARO	11.000	11.500	11.186	11.314	11.353	3,940	1,070	11,380	2,810	0.52
SA120ARO	12.000	12.500	12.186	12.314	12.349	4,290	1,130	12,390	2,970	0.56

Brass; one piece pocket separator
standard 1/8" balls

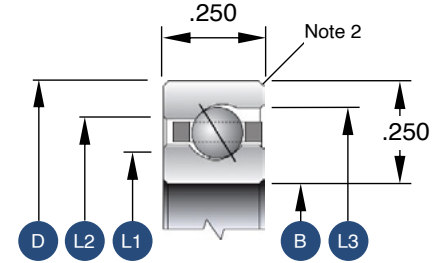

1. Load capacities are not additive
2. The maximum shaft or housing fillet radius that the bearing corners will clear for this series is 0.025"
3. Race Width Tolerance: +0.000 -0.005"



SB SERIES 5/16" X 5/16"

SILVERTHIN PART NUMBER	DIMENSIONS IN INCHES					CAPACITIES IN POUNDS				APPROX WEIGHT POUNDS
	BORE DIAMETER "B"	OUTSIDE DIAMETER "D"	LAND DIAMETER "L1"	LAND DIAMETER "L2"	LAND DIAMETER "L3"	RADIAL		THRUST		
						STATIC	DYNAMIC	STATIC	DYNAMIC	
SB020ARO	2.000	2.625	2.231	2.393	2.464	1,090	600	3,150	1,380	0.16
SB025ARO	2.500	3.125	2.731	2.893	2.964	1,340	675	3,860	1,590	0.19
SB030ARO	3.000	3.625	3.231	3.393	3.462	1,550	735	4,470	1,750	0.24
SB035ARO	3.500	4.125	3.731	3.893	3.962	1,790	800	5,180	1,930	0.29
SB040ARO	4.000	4.625	4.231	4.393	4.460	2,040	865	5,890	2,100	0.30
SB042ARO	4.250	4.875	4.481	4.643	4.710	2,150	890	6,200	2,170	0.31
SB045ARO	4.500	5.125	4.731	4.893	4.960	2,250	915	6,500	2,240	0.33
SB047ARO	4.750	5.375	4.981	5.143	5.210	2,390	950	6,910	2,340	0.34
SB050ARO	5.000	5.625	5.231	5.393	5.460	2,500	975	7,210	2,410	0.38
SB055ARO	5.500	6.125	5.731	5.893	5.958	2,740	1,035	7,920	2,560	0.41
SB060ARO	6.000	6.625	6.231	6.393	6.458	2,990	1,090	8,630	2,710	0.44
SB065ARO	6.500	7.125	6.731	6.893	6.958	3,200	1,130	9,240	2,840	0.47
SB070ARO	7.000	7.625	7.231	7.393	7.456	3,450	1,185	9,960	2,980	0.50
SB075ARO	7.500	8.125	7.731	7.893	7.955	3,700	1,235	10,670	3,120	0.53
SB080ARO	8.000	8.625	8.231	8.393	8.453	3,940	1,285	11,380	3,260	0.57
SB090ARO	9.000	9.625	9.231	9.393	9.451	4,400	1,370	12,700	3,510	0.66
SB100ARO	10.000	10.625	10.231	10.393	10.449	4,890	1,460	14,120	3,760	0.73
SB110ARO	11.000	11.625	11.231	11.393	11.447	5,350	1,540	15,440	4,000	0.75
SB120ARO	12.000	12.625	12.231	12.393	12.445	5,840	1,625	16,860	4,240	0.83
SB140ARO	14.000	14.625	14.231	14.393	14.439	6,760	1,765	19,500	4,670	1.05
SB160ARO	16.000	16.625	16.231	16.393	16.433	7,710	1,905	22,250	5,100	1.20
SB180ARO	18.000	18.625	18.231	18.393	18.425	8,660	2,040	24,990	5,510	1.35
SB200ARO	20.000	20.625	20.231	20.393	20.416	9,610	2,160	27,730	5,900	1.50

Brass; one piece pocket separator
standard 5/32" balls

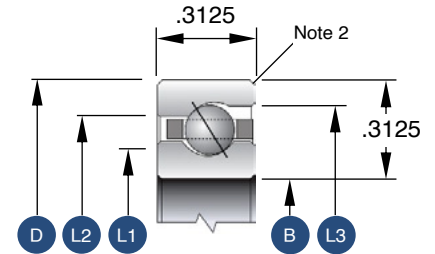

1. Load capacities are not additive
2. The maximum shaft or housing fillet radius that the bearing corners will clear for this series is 0.040"
3. Race Width Tolerance: +0.000 -0.005"



SC SERIES 3/8" X 3/8"

SILVERTHIN PART NUMBER	DIMENSIONS IN INCHES					CAPACITIES IN POUNDS				APPROX WEIGHT POUNDS
	BORE DIAMETER "B"	OUTSIDE DIAMETER "D"	LAND DIAMETER "L1"	LAND DIAMETER "L2"	LAND DIAMETER "L3"	RADIAL		THRUST		
						STATIC	DYNAMIC	STATIC	DYNAMIC	
SC040ARO	4.000	4.750	4.277	4.473	4.554	2,550	1,155	7,360	2,770	0.45
SC042ARO	4.250	5.000	4.527	4.723	4.804	2,710	1,195	7,820	2,880	0.47
SC045ARO	4.500	5.250	4.777	4.973	5.052	2,860	1,235	8,270	2,990	0.48
SC047ARO	4.750	5.500	5.027	5.223	5.302	3,020	1,275	8,720	3,100	0.50
SC050ARO	5.000	5.750	5.277	5.473	5.552	3,180	1,315	9,170	3,200	0.58
SC055ARO	5.500	6.250	5.777	5.973	6.052	3,440	1,375	9,920	3,370	0.59
SC060ARO	6.000	6.750	6.277	6.473	6.550	3,750	1,450	10,820	3,580	0.63
SC065ARO	6.500	7.250	6.777	6.973	7.050	4,060	1,520	11,720	3,770	0.68
SC070ARO	7.000	7.750	7.277	7.473	7.550	4,320	1,575	12,470	3,930	0.73
SC075ARO	7.500	8.250	7.777	7.973	8.048	4,630	1,640	13,380	4,120	0.78
SC080ARO	8.000	8.750	8.277	8.473	8.548	4,950	1,710	14,280	4,300	0.84
SC090ARO	9.000	9.750	9.277	9.473	9.546	5,520	1,820	15,930	4,630	0.94
SC100ARO	10.000	10.750	10.277	10.473	10.544	6,140	1,940	17,730	4,970	1.06
SC110ARO	11.000	11.750	11.277	11.473	11.542	6,720	2,045	19,390	5,280	1.16
SC120ARO	12.000	12.750	12.277	12.473	12.540	7,290	2,145	21,040	5,570	1.25
SC140ARO	14.000	14.750	14.277	14.473	14.535	8,490	2,345	24,500	6,170	1.52
SC160ARO	16.000	16.750	16.277	16.473	16.529	9,680	2,535	27,950	6,730	1.73
SC180ARO	18.000	18.750	18.277	18.473	18.523	10,880	2,705	31,410	7,280	1.94
SC200ARO	20.000	20.750	20.277	20.473	20.517	12,030	2,865	34,720	7,780	2.16
SC250ARO	25.000	25.750	25.277	25.473	25.500	14,900	3,235	43,280	9,010	2.69
SC300ARO	30.000	30.750	30.277	30.473	30.484	17,960	3,560	51,850	10,160	3.21

Brass; one piece pocket separator
standard 3/16" balls

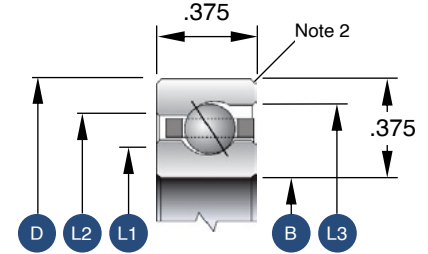

1. Load capacities are not additive
2. The maximum shaft or housing fillet radius that the bearing corners will clear for this series is 0.040"
3. Race Width Tolerance: +0.000 -0.005"



SD SERIES 1/2" X 1/2"

SILVERTHIN PART NUMBER	DIMENSIONS IN INCHES					CAPACITIES IN POUNDS				APPROX WEIGHT POUNDS
	BORE DIAMETER "B"	OUTSIDE DIAMETER "D"	LAND DIAMETER "L1"	LAND DIAMETER "L2"	LAND DIAMETER "L3"	RADIAL		THRUST		
						STATIC	DYNAMIC	STATIC	DYNAMIC	
SD040ARO	4.000	5.000	4.370	4.630	4.741	3,550	1,820	10,260	4,260	0.78
SD042ARO	4.250	5.250	4.620	4.880	4.991	3,750	1,875	10,830	4,420	0.83
SD045ARO	4.50	5.500	4.870	5.130	5.241	3,950	1,930	11,400	4,570	0.88
SD047ARO	4.750	5.750	5.120	5.380	5.490	4,150	1,985	11,970	4,720	0.94
SD050ARO	5.000	6.000	5.370	5.630	5.740	4,340	2,040	12,540	4,870	1.00
SD055ARO	5.500	6.500	5.870	6.130	6.238	4,740	2,145	13,680	5,160	1.06
SD060ARO	6.000	7.000	6.370	6.630	6.738	5,130	2,245	14,820	5,440	1.16
SD065ARO	6.500	7.500	6.870	7.130	7.236	5,530	2,345	15,960	5,720	1.22
SD070ARO	7.000	8.000	7.370	7.630	7.736	5,920	2,440	17,100	5,990	1.31
SD075ARO	7.500	8.500	7.870	8.130	8.236	6,320	2,535	18,240	6,250	1.41
SD080ARO	8.000	9.000	8.370	8.630	8.734	6,710	2,625	19,380	6,510	1.53
SD090ARO	9.000	10.000	9.370	9.630	9.732	7,500	2,805	21,660	7,010	1.72
SD100ARO	10.000	11.000	10.370	10.630	10.732	8,290	2,970	23,940	7,500	1.88
SD110ARO	11.000	12.000	11.370	11.630	11.730	9,080	3,135	26,220	7,960	2.06
SD120ARO	12.000	13.000	12.370	12.630	12.728	9,870	3,290	28,500	8,420	2.25
SD140ARO	14.000	15.000	14.370	14.630	14.724	11,450	3,580	33,060	9,290	2.73
SD160ARO	16.000	17.000	16.370	16.630	16.718	13,030	3,855	37,620	10,130	3.10
SD180ARO	18.000	19.000	18.370	18.630	18.712	14,610	4,115	42,180	10,930	3.48
SD200ARO	20.000	21.000	20.370	20.630	20.705	16,190	4,355	46,740	11,710	3.85
SD250ARO	25.000	26.000	25.370	25.630	25.688	20,140	4,910	58,140	13,540	4.79
SD300ARO	30.000	31.000	30.370	30.630	30.672	24,090	5,395	69,540	15,260	5.73

Brass; one piece pocket separator
standard 1/4" balls

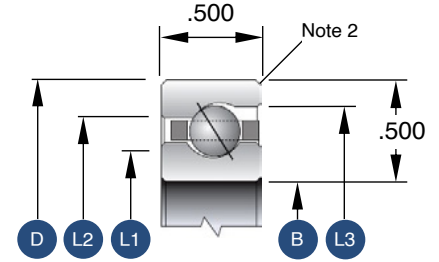

1. Load capacities are not additive
2. The maximum shaft or housing fillet radius that the bearing corners will clear for this series is 0.060"
3. Race Width Tolerance: +0.000 -0.005"



SF SERIES 3/4" X 3/4"

SILVERTHIN PART NUMBER	DIMENSIONS IN INCHES					CAPACITIES IN POUNDS				APPROX WEIGHT POUNDS
	BORE DIAMETER "B"	OUTSIDE DIAMETER "D"	LAND DIAMETER "L1"	LAND DIAMETER "L2"	LAND DIAMETER "L3"	RADIAL		THRUST		
						STATIC	DYNAMIC	STATIC	DYNAMIC	
SF040ARO	4.000	5.500	4.555	4.945	5.115	6,350	3,735	18,340	8,420	1.90
SF042ARO	4.250	5.750	4.805	5.195	5.365	6,600	3,805	19,050	8,630	2.00
SF045ARO	4.500	6.000	5.060	5.445	5.615	7,090	3,965	20,460	9,050	2.10
SF047ARO	4.750	6.250	5.305	5.695	5.865	7,330	4,035	21,160	9,260	2.20
SF050ARO	5.000	6.500	5.555	5.945	6.115	7,570	4,100	21,870	9,460	2.30
SF055ARO	5.500	7.000	6.055	6.445	6.613	8,310	4,320	23,980	10,060	2.50
SF060ARO	6.000	7.500	6.555	6.945	7.113	9,040	4,530	26,100	10,650	2.70
SF065ARO	6.500	8.000	7.055	7.445	7.613	9,770	4,735	28,220	11,220	2.90
SF070ARO	7.000	8.500	7.555	7.945	8.113	10,510	4,930	30,330	11,770	3.20
SF075ARO	7.500	9.000	8.055	8.445	8.610	11,000	5,050	31,740	12,130	3.40
SF080ARO	8.000	9.500	8.555	8.945	9.110	11,730	5,240	33,860	12,670	3.50
SF090ARO	9.000	10.500	9.555	9.945	10.108	13,190	5,610	38,090	13,700	3.90
SF100ARO	10.000	11.500	10.555	10.945	11.106	14,420	5,890	41,620	14,530	4.30
SF110ARO	11.000	12.500	11.555	11.945	12.106	15,880	6,225	45,850	15,500	4.80
SF120ARO	12.000	13.500	12.555	12.945	13.104	17,100	6,485	49,380	16,290	5.20
SF140ARO	14.000	15.500	14.555	14.945	15.102	19,790	7,045	57,140	17,950	6.00
SF160ARO	16.000	17.500	16.555	16.945	17.098	22,480	7,565	64,890	19,540	7.10
SF180ARO	18.000	19.500	18.555	18.945	19.096	25,410	8,105	73,360	21,210	7.90
SF200ARO	20.000	21.500	20.555	20.945	21.092	28,100	8,560	81,120	22,680	8.90
SF250ARO	25.000	26.500	25.555	25.945	26.085	34,700	9,585	100,200	26,100	10.90
SF300ARO	30.000	31.500	30.555	30.945	31.075	41,540	10,535	119,900	29,430	13.00
SF350ARO	35.000	36.500	35.555	35.945	36.064	48,380	11,380	139,700	32,580	15.10

Brass; one piece pocket separator
standard 3/8" balls

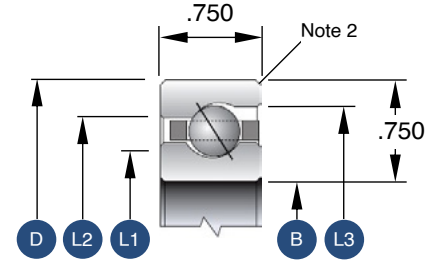

1. Load capacities are not additive
2. The maximum shaft or housing fillet radius that the bearing corners will clear for this series is 0.080"
3. Race Width Tolerance: +0.000 -0.005"

SG SERIES 1" X 1"

SILVERTHIN PART NUMBER	DIMENSIONS IN INCHES					CAPACITIES IN POUNDS				APPROX WEIGHT POUNDS
	BORE DIAMETER "B"	OUTSIDE DIAMETER "D"	LAND DIAMETER "L1"	LAND DIAMETER "L2"	LAND DIAMETER "L3"	RADIAL		THRUST		
						STATIC	DYNAMIC	STATIC	DYNAMIC	
SG040ARO	4.000	6.000	4.742	5.258	5.491	9,480	6,280	27,360	13,630	3.60
SG042ARO	4.250	6.250	4.992	5.508	5.741	9,950	6,440	28,730	14,090	3.80
SG045ARO	4.500	6.500	5.242	5.758	5.989	10,430	6,560	30,100	14,530	4.00
SG047ARO	4.750	6.750	5.492	6.008	6.239	10,900	6,745	31,460	14,970	4.10
SG050ARO	5.000	7.000	5.742	6.258	6.489	11,370	6,895	32,830	15,400	4.30
SG055ARO	5.500	7.500	6.242	6.758	6.989	12,320	7,190	35,570	16,240	4.70
SG060ARO	6.000	8.000	6.742	7.258	7.489	13,270	7,480	38,300	17,060	5.10
SG065ARO	6.500	8.500	7.242	7.758	7.987	14,220	7,760	41,040	17,870	5.40
SG070ARO	7.000	9.000	7.742	8.258	8.487	15,160	8,035	43,780	18,650	5.80
SG075ARO	7.500	9.500	8.242	8.758	8.987	16,110	8,305	46,510	19,420	6.10
SG080ARO	8.000	10.000	8.742	9.258	9.485	17,060	8,565	49,250	20,180	6.50
SG090ARO	9.000	11.000	9.742	10.258	10.485	18,960	9,075	54,720	21,640	7.20
SG100ARO	10.000	12.000	10.742	11.258	11.483	20,850	9,560	60,190	23,060	7.90
SG110ARO	11.000	13.000	11.742	12.258	12.481	22,750	10,025	65,660	24,440	8.60
SG120ARO	12.000	14.000	12.742	13.258	13.481	24,640	10,480	71,140	25,780	9.30
SG140ARO	14.000	16.000	14.742	15.258	15.478	28,430	11,340	82,080	28,360	10.80
SG160ARO	16.000	18.000	16.742	17.258	17.474	32,220	12,140	93,020	30,830	12.30
SG180ARO	18.000	20.000	18.742	19.258	19.472	36,020	12,900	104,000	33,200	13.70
SG200ARO	20.000	22.000	20.742	21.258	21.468	39,810	13,610	114,900	35,490	15.80
SG250ARO	25.000	27.000	25.742	26.258	26.461	49,280	15,240	142,300	40,920	19.50
SG300ARO	30.000	32.000	30.742	31.258	31.451	58,760	16,685	169,600	46,020	23.30
SG350ARO	35.000	37.000	35.742	36.258	36.440	68,240	17,980	197,000	50,840	27.10

Brass; one piece pocket separator
standard 1/2" balls

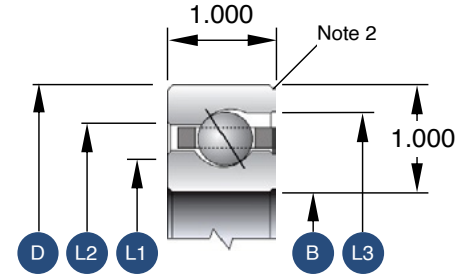

1. Load capacities are not additive
2. The maximum shaft or housing fillet radius that the bearing corners will clear for this series is 0.080"
3. Race Width Tolerance: +0.000-0.005"

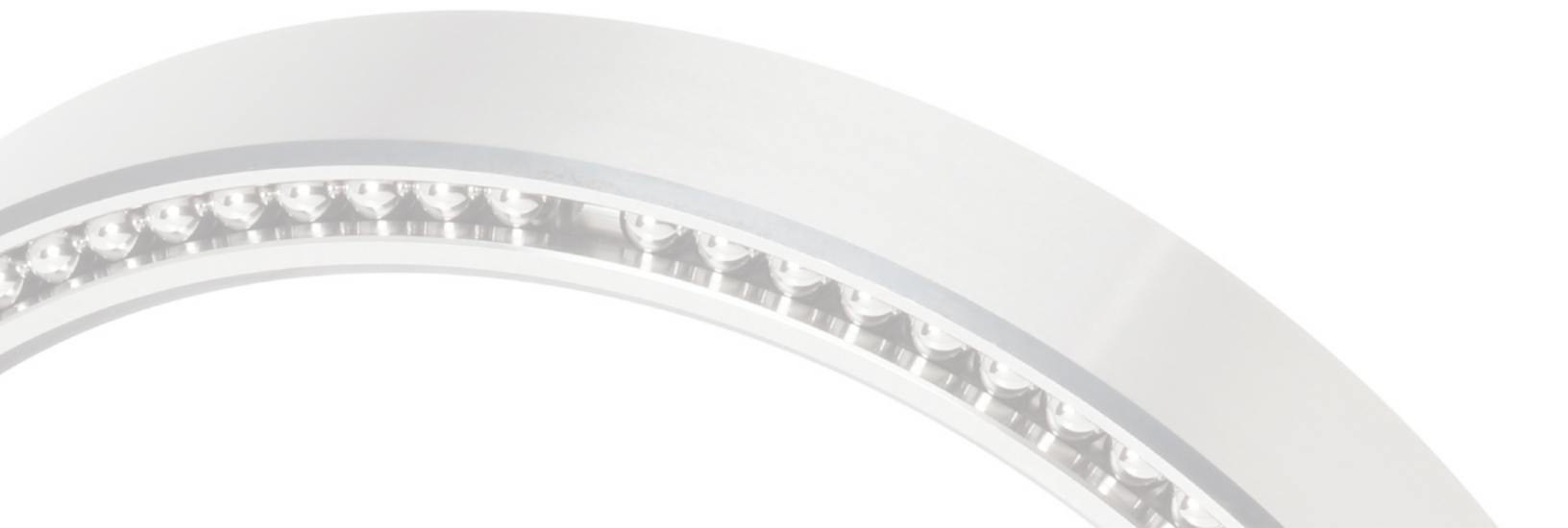

Inch Open Type C

Radial Contact Bearings



The Type C, radial contact ball bearing is designed with deep ball grooves to withstand high loads. Although this bearing is used primarily in applications with radial loads, it can withstand moderate axial loads, reversing axial loads, and moment loads.

Contact Silverthin™ for radial bearing use with combined radial loads, with axial or moment loading, and for limiting speeds and separator selection.

LOAD CONDITION				
RADIAL	AXIAL	MOMENT	REVERSING AXIAL	COMBINED RADIAL-THRUST
Excellent	Good	Good (Light Loading)	Good (Light Loading)	Good

SAA SERIES 3/16" X 3/16"

SILVERTHIN PART NUMBER	DIMENSIONS IN INCHES				CAPACITIES IN POUNDS		APPROX WEIGHT POUNDS
	BORE DIAMETER "B"	OUTSIDE DIAMETER "D"	LAND DIAMETER "L1"	LAND DIAMETER "L2"	RADIAL		
					STATIC	DYNAMIC	
SAA10CLO	1.000	1.375	1.140	1.235	290	190	0.03
SAA15CLO	1.500	1.875	1.640	1.735	400	225	0.04
SAA17CLO	1.750	2.125	1.890	1.985	460	240	0.04

Nylon; one piece snapover separator
standard 3/32" balls

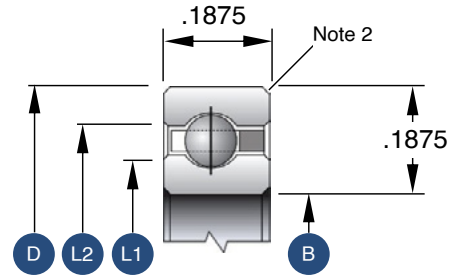

1. Load capacities are not additive
2. The maximum shaft or housing fillet radius that the bearing corners will clear for this series is 0.015"
3. Race Width Tolerance: +0.000 -0.005"



SA SERIES 1/4" X 1/4"

SILVERTHIN PART NUMBER	DIMENSIONS IN INCHES				CAPACITIES IN POUNDS		APPROX WEIGHT POUNDS
	BORE DIAMETER "B"	OUTSIDE DIAMETER "D"	LAND DIAMETER "L1"	LAND DIAMETER "L2"	RADIAL		
					STATIC	DYNAMIC	
SA020CPO	2.000	2.500	2.186	2.314	680	395	0.10
SA025CPO	2.500	3.000	2.686	2.814	830	440	0.13
SA030CPO	3.000	3.500	3.186	3.314	990	485	0.15
SA035CPO	3.500	4.000	3.686	3.814	1,140	530	0.18
SA040CPO	4.000	4.500	4.186	4.314	1,290	570	0.19
SA042CPO	4.250	4.750	4.436	4.564	1,370	590	0.20
SA045CPO	4.500	5.000	4.686	4.814	1,440	610	0.22
SA047CPO	4.750	5.250	4.936	5.064	1,520	630	0.23
SA050CPO	5.000	5.500	5.186	5.314	1,590	650	0.24
SA055CPO	5.500	6.000	5.686	5.814	1,750	685	0.25
SA060CPO	6.000	6.500	6.186	6.314	1,900	720	0.28
SA065CPO	6.500	7.000	6.686	6.814	2,050	755	0.30
SA070CPO	7.000	7.500	7.186	7.314	2,200	785	0.31
SA075CPO	7.500	8.000	7.686	7.814	2,350	820	0.34
SA080CPO	8.000	8.500	8.186	8.314	2,500	850	0.38
SA090CPO	9.000	9.500	9.186	9.314	2,810	910	0.44
SA100CPO	10.000	10.500	10.186	10.314	3,110	970	0.50
SA110CPO	11.000	11.500	11.186	11.314	3,410	1,025	0.52
SA120CPO	12.000	12.500	12.186	12.314	3,720	1,080	0.56

Brass; snapover separator standard 1/8" balls

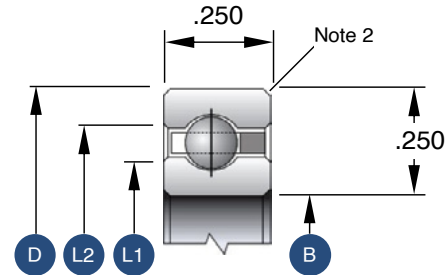

1. Load capacities are not additive
2. The maximum shaft or housing fillet radius that the bearing corners will clear for this series is 0.025"
3. Race Width Tolerance: +0.000 -0.005"



SB SERIES 5/16" X 5/16"

SILVERTHIN PART NUMBER	DIMENSIONS IN INCHES				CAPACITIES IN POUNDS		APPROX WEIGHT POUNDS
	BORE DIAMETER "B"	OUTSIDE DIAMETER "D"	LAND DIAMETER "L1"	LAND DIAMETER "L2"	RADIAL		
					STATIC	DYNAMIC	
SB020CPO	2.000	2.625	2.231	2.393	930	575	0.16
SB025CPO	2.500	3.125	2.731	2.893	1,140	645	0.19
SB030CPO	3.000	3.625	3.231	3.393	1,340	705	0.24
SB035CPO	3.500	4.125	3.731	3.893	1,540	765	0.29
SB040CPO	4.000	4.625	4.231	4.393	1,750	825	0.30
SB042CPO	4.250	4.875	4.481	4.643	1,830	845	0.31
SB045CPO	4.500	5.125	4.731	4.893	1,950	880	0.33
SB047CPO	4.750	5.375	4.981	5.143	2,030	900	0.34
SB050CPO	5.000	5.625	5.231	5.393	2,150	935	0.38
SB055CPO	5.500	6.125	5.731	5.893	2,360	985	0.41
SB060CPO	6.000	6.625	6.231	6.393	2,560	1,035	0.44
SB065CPO	6.500	7.125	6.731	6.893	2,760	1,080	0.47
SB070CPO	7.000	7.625	7.231	7.393	2,970	1,130	0.50
SB075CPO	7.500	8.125	7.731	7.893	3,170	1,175	0.53
SB080CPO	8.000	8.625	8.231	8.393	3,370	1,220	0.57
SB090CPO	9.000	9.625	9.231	9.393	3,780	1,305	0.66
SB100CPO	10.000	10.625	10.231	10.393	4,190	1,385	0.73
SB110CPO	11.000	11.625	11.231	11.393	4,590	1,465	0.75
SB120CPO	12.000	12.625	12.231	12.393	5,000	1,540	0.83
SB140CPO	14.000	14.625	14.231	14.393	5,810	1,680	1.05
SB160CPO	16.000	16.625	16.231	16.393	6,620	1,810	1.20
SB180CPO	18.000	18.625	18.231	18.393	7,440	1,935	1.35
SB200CPO	20.000	20.625	20.231	20.393	8,250	2,055	1.50

Brass; snapover separator standard
5/32" balls

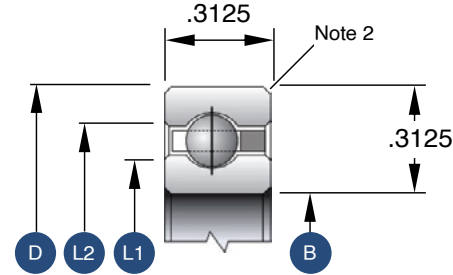

1. Load capacities are not additive
2. The maximum shaft or housing fillet radius that the bearing corners will clear for this series is 0.040"
3. Race Width Tolerance: +0.000 -0.005"



SC SERIES 3/8" X 3/8"

SILVERTHIN PART NUMBER	DIMENSIONS IN INCHES				CAPACITIES IN POUNDS		APPROX WEIGHT POUNDS
	BORE DIAMETER "B"	OUTSIDE DIAMETER "D"	LAND DIAMETER "L1"	LAND DIAMETER "L2"	RADIAL		
					STATIC	DYNAMIC	
SC040CP0	4.000	4.750	4.277	4.473	2,100	1,075	0.16
SC042CP0	4.250	5.000	4.527	4.723	2,220	1,110	0.19
SC045CP0	4.500	5.250	4.777	4.973	2,340	1,145	0.45
SC047CP0	4.750	5.500	5.027	5.223	2,460	1,175	0.47
SC050CP0	5.000	5.750	5.277	5.473	2,590	1,210	0.48
SC055CP0	5.500	6.250	5.777	5.973	2,830	1,275	0.50
SC060CP0	6.000	6.750	6.277	6.473	3,070	1,335	0.58
SC065CP0	6.500	7.250	6.777	6.973	3,310	1,395	0.59
SC070CP0	7.000	7.750	7.277	7.473	3,550	1,455	0.63
SC075CP0	7.500	8.250	7.777	7.973	3,790	1,515	0.68
SC080CP0	8.000	8.750	8.277	8.473	4,030	1,570	0.73
SC090CP0	9.000	9.750	9.277	9.473	4,510	1,680	0.78
SC100CP0	10.000	10.750	10.277	10.473	4,990	1,780	0.84
SC110CP0	11.000	11.750	11.277	11.473	5,470	1,880	0.94
SC120CP0	12.000	12.750	12.277	12.473	5,950	1,975	1.06
SC140CP0	14.000	14.750	14.277	14.473	6,910	2,155	1.16
SC160CP0	16.000	16.750	16.277	16.473	7,880	2,320	1.25
SC180CP0	18.000	18.750	18.277	18.473	8,840	2,480	1.52
SC200CP0	20.000	20.750	20.277	20.473	9,800	2,625	1.73
SC250CP0	25.000	25.750	25.277	25.473	12,200	2,960	1.94
SC300CP0	30.000	30.750	30.277	30.473	14,610	3,260	2.16

Brass; snapover separator standard
3/16" balls

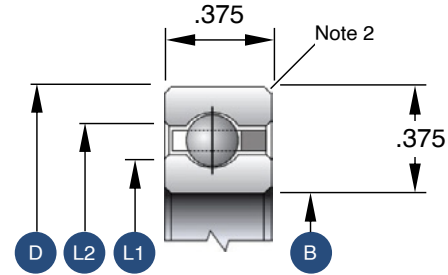

1. Load capacities are not additive
2. The maximum shaft or housing fillet radius that the bearing corners will clear for this series is 0.040"
3. Race Width Tolerance: +0.000 -0.005"

SD SERIES 1/2" X 1/2"

SILVERTHIN PART NUMBER	DIMENSIONS IN INCHES				CAPACITIES IN POUNDS		APPROX WEIGHT POUNDS
	BORE DIAMETER "B"	OUTSIDE DIAMETER "D"	LAND DIAMETER "L1"	LAND DIAMETER "L2"	RADIAL		
					STATIC	DYNAMIC	
SD040CPO	4.000	5.000	4.370	4.630	3,080	1,755	0.78
SD042CPO	4.250	5.250	4.620	4.880	3,190	1,785	0.83
SD045CPO	4.500	5.500	4.870	5.130	3,420	1,860	0.88
SD047CPO	4.750	5.750	5.120	5.380	3,530	1,890	0.94
SD050CPO	5.000	6.000	5.370	5.630	3,760	1,965	1.00
SD055CPO	5.500	6.500	5.870	6.130	4,100	2,065	1.06
SD060CPO	6.000	7.000	6.370	6.630	4,450	2,160	1.16
SD065CPO	6.500	7.500	6.870	7.130	4,790	2,255	1.22
SD070CPO	7.000	8.000	7.370	7.630	5,130	2,345	1.31
SD075CPO	7.500	8.500	7.870	8.130	5,470	2,435	1.41
SD080CPO	8.000	9.000	8.370	8.630	5,810	2,520	1.53
SD090CPO	9.000	10.000	9.370	9.630	6,500	2,690	1.72
SD100CPO	10.000	11.000	10.370	10.630	7,180	2,845	1.88
SD110CPO	11.000	12.000	11.370	11.630	7,870	3,000	2.06
SD120CPO	12.000	13.000	12.370	12.630	8,550	3,150	2.25
SD140CPO	14.000	15.000	14.370	14.630	9,920	3,425	2.73
SD160CPO	16.000	17.000	16.370	16.630	11,290	3,690	3.10
SD180CPO	18.000	19.000	18.370	18.630	12,650	3,935	3.48
SD200CPO	20.000	21.000	20.370	20.630	14,020	4,165	3.85
SD250CPO	25.000	26.000	25.370	25.630	17,440	4,690	4.79
SD300CPO	30.000	31.000	30.370	30.630	20,860	5,155	5.73

Brass; snapover separator standard
1/4" balls

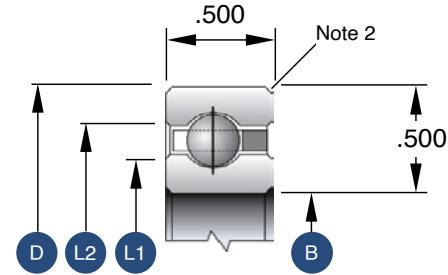

1. Load capacities are not additive
2. The maximum shaft or housing fillet radius that the bearing corners will clear for this series is 0.060"
3. Race Width Tolerance: +0.000 -0.005"

SF SERIES 3/4" X 3/4"

SILVERTHIN PART NUMBER	DIMENSIONS IN INCHES				CAPACITIES IN POUNDS		APPROX WEIGHT POUNDS
	BORE DIAMETER "B"	OUTSIDE DIAMETER "D"	LAND DIAMETER "L1"	LAND DIAMETER "L2"	RADIAL		
					STATIC	DYNAMIC	
SF040CP0	4.000	5.500	4.555	4.945	5,360	3,560	1.90
SF042CP0	4.250	5.750	4.805	5.195	5,640	3,655	2.00
SF045CP0	4.500	6.000	5.060	5.445	5,930	3,750	2.10
SF047CP0	4.750	6.250	5.305	5.695	6,210	3,845	2.20
SF050CP0	5.000	6.500	5.555	5.945	6,490	3,935	2.30
SF055CP0	5.500	7.000	6.055	6.445	7,050	4,115	2.50
SF060CP0	6.000	7.500	6.555	6.945	7,620	4,290	2.70
SF065CP0	6.500	8.000	7.055	7.445	8,180	4,460	2.90
SF070CP0	7.000	8.500	7.555	7.945	8,750	4,630	3.20
SF075CP0	7.500	9.000	8.055	8.445	9,310	4,790	3.40
SF080CP0	8.000	9.500	8.555	8.945	9,880	4,950	3.50
SF090CP0	9.000	10.500	9.555	9.945	11,000	5,255	3.90
SF100CP0	10.000	11.500	10.555	10.945	12,130	5,550	4.30
SF110CP0	11.000	12.500	11.555	11.945	13,260	5,835	4.80
SF120CP0	12.000	13.500	12.555	12.945	14,390	6,105	5.20
SF140CP0	14.000	15.500	14.555	14.945	16,650	6,620	6.00
SF160CP0	16.000	17.500	16.555	16.945	18,900	7,105	7.10
SF180CP0	18.000	19.500	18.555	18.945	21,160	7,555	7.90
SF200CP0	20.000	21.500	20.555	20.945	23,420	7,985	8.90
SF250CP0	25.000	26.500	25.555	25.945	29,060	8,965	10.90
SF300CP0	30.000	31.500	30.555	30.945	34,700	9,830	13.00
SF350CP0	35.000	36.500	35.555	35.945	40,350	10,605	15.10

Brass; snapover separator standard
3/8" balls

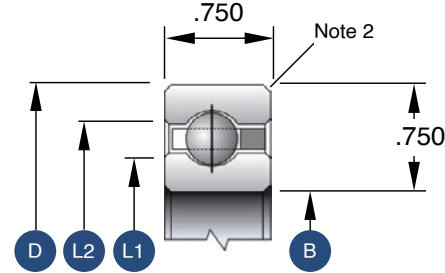

1. Load capacities are not additive
2. The maximum shaft or housing fillet radius that the bearing corners will clear for this series is 0.080"
3. Race Width Tolerance: +0.000 -0.005"



SG SERIES 1" X 1"

SILVERTHIN PART NUMBER	DIMENSIONS IN INCHES				CAPACITIES IN POUNDS		APPROX WEIGHT POUNDS
	BORE DIAMETER "B"	OUTSIDE DIAMETER "D"	LAND DIAMETER "L1"	LAND DIAMETER "L2"	RADIAL		
					STATIC	DYNAMIC	
SG040CP0	4.000	6.000	4.742	5.258	8,210	6,115	3.60
SG042CP0	4.250	6.250	4.992	5.508	8,210	6,060	3.80
SG045CP0	4.500	6.500	5.242	5.758	8,760	6,225	4.00
SG047CP0	4.750	6.750	5.492	6.008	9,300	6,485	4.10
SG050CP0	5.000	7.000	5.742	6.258	9,850	6,690	4.30
SG055CP0	5.500	7.500	6.242	6.758	10,400	6,850	4.70
SG060CP0	6.000	8.000	6.742	7.258	11,490	7,240	5.10
SG065CP0	6.500	8.500	7.242	7.758	12,040	7,395	5.40
SG070CP0	7.000	9.000	7.742	8.258	13,130	7,765	5.80
SG075CP0	7.500	9.500	8.242	8.758	13,680	7,910	6.10
SG080CP0	8.000	10.000	8.742	9.258	14,770	8,265	6.50
SG090CP0	9.000	11.000	9.742	10.258	16,420	8,745	7.20
SG100CP0	10.000	12.000	10.742	11.258	18,060	9,205	7.90
SG110CP0	11.000	13.000	11.742	12.258	19,700	9,650	8.60
SG120CP0	12.000	14.000	12.742	13.258	21,340	10,075	9.30
SG140CP0	14.000	16.000	14.742	15.258	24,620	10,885	10.80
SG160CP0	16.000	18.000	16.742	17.258	27,910	11,650	12.30
SG180CP0	18.000	20.000	18.742	19.258	31,190	12,365	13.70
SG200CP0	20.000	22.000	20.742	21.258	34,470	13,045	15.80
SG250CP0	25.000	27.000	25.742	26.258	42,680	14,595	19.50
SG300CP0	30.000	32.000	30.742	31.258	50,890	15,965	23.30
SG350CP0	35.000	37.000	35.742	36.258	59,100	17,195	27.10

Brass; snapover separator standard
1/2" balls

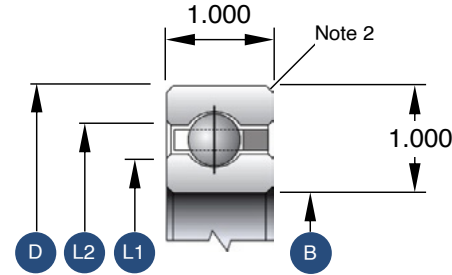

1. Load capacities are not additive
2. The maximum shaft or housing fillet radius that the bearing corners will clear for this series is 0.080"
3. Race Width Tolerance: +0.000 -0.005"



Inch Open Type X

4-Point Contact Bearings



The Type X, or 4-point contact, ball bearing is ideal for moment loading. Type X bearings are designed with gothic arch raceways creating 4 contact points between the balls and the raceways. This design is excellent for moment loading and reversing axial loading. In many cases a single Type X bearing can replace 2 bearings resulting in simplified designs.

The Type X bearing can be used for other light loading conditions, but is not recommended in place of the C- or Type A bearing for pure radial loads. Contact Silverthin™ for information on combined load and limiting speeds.

LOAD CONDITION				
RADIAL	AXIAL	MOMENT	REVERSING AXIAL	COMBINED RADIAL-THRUST
Poor	Good	Excellent	Excellent	Poor

SAA SERIES 3/16" X 3/16"

SILVERTHIN PART NUMBER	DIMENSIONS IN INCHES				CAPACITIES IN POUNDS						APPROX WEIGHT POUNDS
	BORE DIAMETER "B"	OUTSIDE DIAMETER "D"	LAND DIAMETER "L1"	LAND DIAMETER "L2"	RADIAL		THRUST		MOMENT (LBS-in)		
					STATIC	DYNAMIC	STATIC	DYNAMIC	STATIC	DYNAMIC	
SAA10XLO	1.000	1.375	1.140	1.235	290	245	730	370	170	110	0.03
SAA15XLO	1.500	1.875	1.640	1.735	400	295	1,000	460	340	185	0.04
SAA17XLO	1.750	2.125	1.890	1.985	460	320	1,140	500	440	230	0.04

Nylon; one piece snapover separator standard 3/32" balls

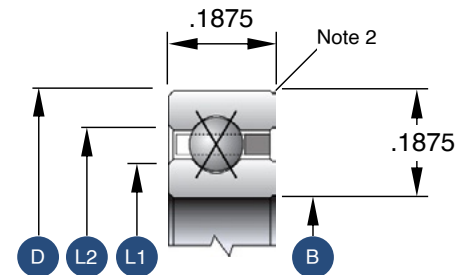

1. Load capacities are not additive
2. The maximum shaft or housing fillet radius that the bearing corners will clear for this series is 0.015"
3. Race Width Tolerance: +0.000 -0.005"



SA SERIES 1/4" X 1/4"

SILVERTHIN PART NUMBER	DIMENSIONS IN INCHES				CAPACITIES IN POUNDS						APPROX WEIGHT POUNDS
	BORE DIAMETER "B"	OUTSIDE DIAMETER "D"	LAND DIAMETER "L1"	LAND DIAMETER "L2"	RADIAL		THRUST		MOMENT (LBS-in)		
					STATIC	DYNAMIC	STATIC	DYNAMIC	STATIC	DYNAMIC	
SA020XPO	2.000	2.500	2.186	2.314	680	515	1,710	790	770	435	0.10
SA025XPO	2.500	3.000	2.686	2.814	830	585	2,090	910	1,150	600	0.13
SA030XPO	3.000	3.500	3.186	3.314	990	645	2,470	1,010	1,600	785	0.15
SA035XPO	3.500	4.000	3.686	3.814	1,140	700	2,850	1,110	2,130	985	0.18
SA040XPO	4.000	4.500	4.186	4.314	1,290	755	3,220	1,210	2,740	1,205	0.19
SA042XPO	4.250	4.750	4.436	4.564	1,370	785	3,410	1,260	3,070	1,320	0.20
SA045XPO	4.500	5.000	4.686	4.814	1,440	810	3,600	1,310	3,420	1,440	0.22
SA047XPO	4.750	5.250	4.936	5.064	1,520	835	3,790	1,350	3,790	1,565	0.23
SA050XPO	5.000	5.500	5.186	5.314	1,590	860	3,980	1,400	4,180	1,695	0.24
SA055XPO	5.500	6.000	5.686	5.814	1,750	910	4,360	1,480	5,020	1,960	0.25
SA060XPO	6.000	6.500	6.186	6.314	1,900	955	4,740	1,570	5,930	2,240	0.28
SA065XPO	6.500	7.000	6.686	6.814	2,050	1,000	5,120	1,650	6,910	2,535	0.30
SA070XPO	7.000	7.500	7.186	7.314	2,200	1,045	5,500	1,730	7,980	2,845	0.31
SA075XPO	7.500	8.000	7.686	7.814	2,350	1,090	5,880	1,810	9,120	3,165	0.34
SA080XPO	8.000	8.500	8.186	8.314	2,500	1,130	6,260	1,890	10,330	3,500	0.38
SA090XPO	9.000	9.500	9.186	9.314	2,810	1,210	7,020	2,040	12,990	4,205	0.44
SA100XPO	10.000	10.500	10.186	10.314	3,110	1,290	7,780	2,180	15,940	4,955	0.50
SA110XPO	11.000	11.500	11.186	11.314	3,410	1,360	8,540	2,320	19,210	5,750	0.52
SA120XPO	12.000	12.500	12.186	12.314	3,720	1,435	9,300	2,450	22,770	6,585	0.56

Brass; snapover separator standard
1/8" balls

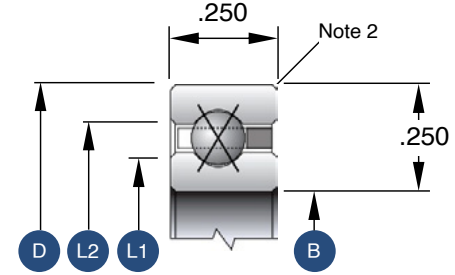

1. Load capacities are not additive
2. The maximum shaft or housing fillet radius that the bearing corners will clear for this series is 0.025"
3. Race Width Tolerance: +0.000 -0.005"



Inch Open Type X

4-Point Contact Bearings



SB SERIES 5/16" X 5/16"

SILVERTHIN PART NUMBER	DIMENSIONS IN INCHES				CAPACITIES IN POUNDS						APPROX WEIGHT POUNDS
	BORE DIAMETER "B"	OUTSIDE DIAMETER "D"	LAND DIAMETER "L1"	LAND DIAMETER "L2"	RADIAL		THRUST		MOMENT (LBS-in)		
					STATIC	DYNAMIC	STATIC	DYNAMIC	STATIC	DYNAMIC	
SB020XPO	2.000	2.625	2.231	2.393	930	760	2,340	1,130	1,080	660	0.16
SB025XPO	2.500	3.125	2.731	2.893	1,140	850	2,840	1,290	1,600	895	0.19
SB030XPO	3.000	3.625	3.231	3.393	1,340	935	3,350	1,440	2,220	1,160	0.24
SB035XPO	3.500	4.125	3.731	3.893	1,540	1,015	3,860	1,590	2,940	1,450	0.29
SB040XPO	4.000	4.625	4.231	4.393	1,750	1,090	4,370	1,720	3,770	1,765	0.30
SB042XPO	4.250	4.875	4.481	4.643	1,830	1,120	4,570	1,780	4,170	1,915	0.31
SB045XPO	4.500	5.125	4.731	4.893	1,950	1,165	4,880	1,850	4,690	2,105	0.33
SB047XPO	4.750	5.375	4.981	5.143	2,030	1,195	5,080	1,900	5,140	2,265	0.34
SB050XPO	5.000	5.625	5.231	5.393	2,150	1,235	5,380	1,980	5,720	2,465	0.38
SB055XPO	5.500	6.125	5.731	5.893	2,360	1,305	5,890	2,100	6,850	2,845	0.41
SB060XPO	6.000	6.625	6.231	6.393	2,560	1,370	6,400	2,220	8,080	3,245	0.44
SB065XPO	6.500	7.125	6.731	6.893	2,760	1,435	6,910	2,340	9,410	3,670	0.47
SB070XPO	7.000	7.625	7.231	7.393	2,970	1,500	7,420	2,450	10,850	4,110	0.50
SB075XPO	7.500	8.125	7.731	7.893	3,170	1,560	7,920	2,560	12,380	4,570	0.53
SB080XPO	8.000	8.625	8.231	8.393	3,370	1,620	8,430	2,670	14,020	5,045	0.57
SB090XPO	9.000	9.625	9.231	9.393	3,780	1,730	9,450	2,880	17,600	6,050	0.66
SB100XPO	10.000	10.625	10.231	10.393	4,190	1,840	10,460	3,080	21,580	7,120	0.73
SB110XPO	11.000	11.625	11.231	11.393	4,590	1,945	11,480	3,280	25,970	8,255	0.75
SB120XPO	12.000	12.625	12.231	12.393	5,000	2,045	12,500	3,470	30,770	9,445	0.83
SB140XPO	14.000	14.625	14.231	14.393	5,810	2,235	14,530	3,840	41,580	11,995	1.05
SB160XPO	16.000	16.625	16.231	16.393	6,620	2,410	16,560	4,190	54,020	14,750	1.20
SB180XPO	18.000	18.625	18.231	18.393	7,440	2,575	18,590	4,520	68,090	17,695	1.35
SB200XPO	20.000	20.625	20.231	20.393	8,250	2,730	20,620	4,850	83,780	20,815	1.50

Brass; snapover separator standard
5/32" balls

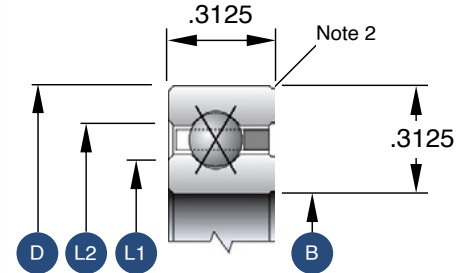

1. Load capacities are not additive
2. The maximum shaft or housing fillet radius that the bearing corners will clear for this series is 0.040"
3. Race Width Tolerance: +0.000 -0.005"



SC SERIES 3/8" X 3/8"

SILVERTHIN PART NUMBER	DIMENSIONS IN INCHES				CAPACITIES IN POUNDS						APPROX WEIGHT POUNDS
	BORE DIAMETER "B"	OUTSIDE DIAMETER "D"	LAND DIAMETER "L1"	LAND DIAMETER "L2"	RADIAL		THRUST		MOMENT (LBS-in)		
					STATIC	DYNAMIC	STATIC	DYNAMIC	STATIC	DYNAMIC	
SC040XP0	4.000	4.750	4.277	4.473	2,100	1,415	5,260	2,210	4,600	2,325	0.45
SC042XP0	4.250	5.000	4.527	4.723	2,220	1,465	5,560	2,290	5,140	2,540	0.47
SC045XP0	4.500	5.250	4.777	4.973	2,340	1,510	5,860	2,380	5,710	2,760	0.48
SC047XP0	4.750	5.500	5.027	5.223	2,460	1,555	6,160	2,460	6,320	2,990	0.50
SC050XP0	5.000	5.750	5.277	5.473	2,590	1,600	6,460	2,540	6,950	3,225	0.58
SC055XP0	5.500	6.250	5.777	5.973	2,830	1,685	7,060	2,690	8,300	3,715	0.59
SC060XP0	6.000	6.750	6.277	6.473	3,070	1,770	7,660	2,840	9,770	4,235	0.63
SC065XP0	6.500	7.250	6.777	6.973	3,310	1,850	8,270	2,990	11,370	4,775	0.68
SC070XP0	7.000	7.750	7.277	7.473	3,550	1,930	8,870	3,130	13,080	5,340	0.73
SC075XP0	7.500	8.250	7.777	7.973	3,790	2,005	9,470	3,270	14,910	5,930	0.78
SC080XP0	8.000	8.750	8.277	8.473	4,030	2,080	10,070	3,410	16,870	6,540	0.84
SC090XP0	9.000	9.750	9.277	9.473	4,510	2,225	11,270	3,670	21,130	7,830	0.94
SC100XP0	10.000	10.750	10.277	10.473	4,990	2,365	12,470	3,930	25,880	9,200	1.06
SC110XP0	11.000	11.750	11.277	11.473	5,470	2,495	13,680	4,180	31,110	10,650	1.16
SC120XP0	12.000	12.750	12.277	12.473	5,950	2,620	14,880	4,420	36,830	12,175	1.25
SC140XP0	14.000	14.750	14.277	14.473	6,910	2,860	17,280	4,890	49,690	15,435	1.52
SC160XP0	16.000	16.750	16.277	16.473	7,880	3,085	19,690	5,330	64,480	18,955	1.73
SC180XP0	18.000	18.750	18.277	18.473	8,840	3,295	22,090	5,760	81,190	22,710	1.94
SC200XP0	20.000	20.750	20.277	20.473	9,800	3,490	24,500	6,170	99,830	26,695	2.16
SC250XP0	25.000	25.750	25.277	25.473	12,200	3,940	30,510	7,140	154,800	37,520	2.69
SC300XP0	30.000	30.750	30.277	30.473	14,610	4,340	36,520	8,050	221,900	49,435	3.21

Brass; snapover separator standard
3/16" balls

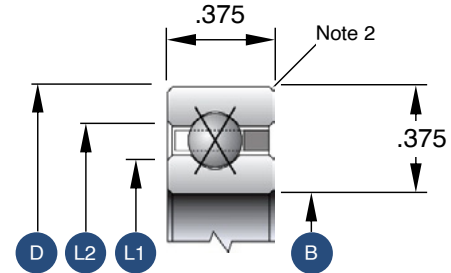

1. Load capacities are not additive
2. The maximum shaft or housing fillet radius that the bearing corners will clear for this series is 0.040"
3. Race Width Tolerance: +0.000 -0.005"



SD SERIES 1/2" X 1/2"

SILVERTHIN PART NUMBER	DIMENSIONS IN INCHES				CAPACITIES IN POUNDS						APPROX WEIGHT POUNDS
	BORE DIAMETER "B"	OUTSIDE DIAMETER "D"	LAND DIAMETER "L1"	LAND DIAMETER "L2"	RADIAL		THRUST		MOMENT (LBS-in)		
					STATIC	DYNAMIC	STATIC	DYNAMIC	STATIC	DYNAMIC	
SD040XPO	4.000	5.000	4.370	4.630	3,080	2,310	7,700	3,520	6,930	3,900	0.78
SD042XPO	4.250	5.250	4.620	4.880	3,190	2,355	7,980	3,600	7,580	4,195	0.83
SD045XPO	4.500	5.500	4.870	5.130	3,420	2,455	8,550	3,770	8,550	4,600	0.88
SD047XPO	4.750	5.750	5.120	5.380	3,530	2,495	8,840	3,860	9,280	4,915	0.94
SD050XPO	5.000	6.000	5.370	5.630	3,760	2,590	9,410	4,020	10,350	5,350	1.00
SD055XPO	5.500	6.500	5.870	6.130	4,100	2,725	10,260	4,260	12,310	6,135	1.06
SD060XPO	6.000	7.000	6.370	6.630	4,450	2,855	11,120	4,490	14,450	6,960	1.16
SD065XPO	6.500	7.500	6.870	7.130	4,790	2,980	11,970	4,720	16,760	7,825	1.22
SD070XPO	7.000	8.000	7.370	7.630	5,130	3,105	12,830	4,940	19,240	8,730	1.31
SD075XPO	7.500	8.500	7.870	8.130	5,470	3,220	13,680	5,160	21,890	9,670	1.41
SD080XPO	8.000	9.000	8.370	8.630	5,810	3,340	14,540	5,370	24,710	10,645	1.53
SD090XPO	9.000	10.000	9.370	9.630	6,500	3,560	16,250	5,790	30,870	12,695	1.72
SD100XPO	10.000	11.000	10.370	10.630	7,180	3,775	17,960	6,190	37,710	14,870	1.88
SD110XPO	11.000	12.000	11.370	11.630	7,870	3,980	19,670	6,570	45,230	17,175	2.06
SD120XPO	12.000	13.000	12.370	12.630	8,550	4,180	21,380	6,950	53,440	19,590	2.25
SD140XPO	14.000	15.000	14.370	14.630	9,920	4,550	24,800	7,670	71,910	24,755	2.73
SD160XPO	16.000	17.000	16.370	16.630	11,290	4,900	28,220	8,360	93,110	30,325	3.10
SD180XPO	18.000	19.000	18.370	18.630	12,650	5,225	31,640	9,030	117,000	36,270	3.48
SD200XPO	20.000	21.000	20.370	20.630	14,020	5,535	35,060	9,670	143,700	42,560	3.85
SD250XPO	25.000	26.000	25.370	25.630	17,440	6,235	43,610	11,180	222,400	59,650	4.79
SD300XPO	30.000	31.000	30.370	30.630	20,860	6,855	52,160	12,600	318,100	78,445	5.73

Brass; snapover separator standard
1/4" balls

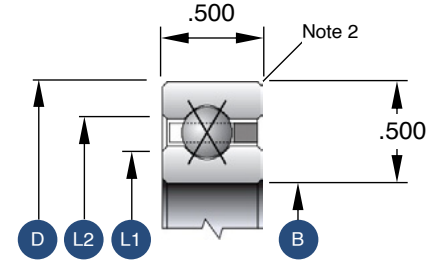

1. Load capacities are not additive
2. The maximum shaft or housing fillet radius that the bearing corners will clear for this series is 0.060"
3. Race Width Tolerance: +0.000 -0.005"

Inch Open Type X 4-Point Contact Bearings



SF SERIES 3/4" X 3/4"

SILVERTHIN PART NUMBER	DIMENSIONS IN INCHES				CAPACITIES IN POUNDS						APPROX WEIGHT POUNDS
	BORE DIAMETER "B"	OUTSIDE DIAMETER "D"	LAND DIAMETER "L1"	LAND DIAMETER "L2"	RADIAL		THRUST		MOMENT (LBS-in)		
					STATIC	DYNAMIC	STATIC	DYNAMIC	STATIC	DYNAMIC	
SF040XPO	4.000	5.500	4.555	4.945	5,360	4,665	13,400	6,830	12,730	8,310	1.90
SF042XPO	4.250	5.750	4.805	5.195	5,640	4,795	14,110	7,070	14,110	8,995	2.00
SF045XPO	4.500	6.000	5.060	5.445	5,930	4,925	14,810	7,300	15,550	9,695	2.10
SF047XPO	4.750	6.250	5.305	5.695	6,210	5,050	15,520	7,530	17,070	10,415	2.20
SF050XPO	5.000	6.500	5.555	5.945	6,490	5,170	16,220	7,760	18,660	11,155	2.30
SF055XPO	5.500	7.000	6.055	6.445	7,050	5,415	17,630	8,200	22,040	12,695	2.50
SF060XPO	6.000	7.500	6.555	6.945	7,620	5,650	19,050	8,630	25,710	14,310	2.70
SF065XPO	6.500	8.000	7.055	7.445	8,180	5,880	20,460	9,050	29,660	15,995	2.90
SF070XPO	7.000	8.500	7.555	7.945	8,750	6,105	21,870	9,460	33,890	17,745	3.20
SF075XPO	7.500	9.000	8.055	8.445	9,310	6,325	23,280	9,870	38,410	19,570	3.40
SF080XPO	8.000	9.500	8.555	8.945	9,880	6,535	24,690	10,260	43,200	21,455	3.50
SF090XPO	9.000	10.500	9.555	9.945	11,000	6,945	27,510	11,030	53,640	25,410	3.90
SF100XPO	10.000	11.500	10.555	10.945	12,130	7,340	30,330	11,770	65,210	29,610	4.30
SF110XPO	11.000	12.500	11.555	11.945	13,260	7,720	33,150	12,490	77,910	34,030	4.80
SF120XPO	12.000	13.500	12.555	12.945	14,390	8,085	35,970	13,190	91,730	38,665	5.20
SF140XPO	14.000	15.500	14.555	14.945	16,650	8,775	41,620	14,530	122,800	48,555	6.00
SF160XPO	16.000	17.500	16.555	16.945	18,900	9,420	47,260	15,820	158,300	59,200	7.10
SF180XPO	18.000	19.500	18.555	18.945	21,160	10,030	52,900	17,060	198,400	70,535	7.90
SF200XPO	20.000	21.500	20.555	20.945	23,420	10,600	58,550	18,250	243,000	82,530	8.90
SF250XPO	25.000	26.500	25.555	25.945	29,060	11,910	72,650	21,070	374,200	115,035	10.90
SF300XPO	30.000	31.500	30.555	30.945	34,700	13,065	86,760	23,720	533,600	150,710	13.00
SF350XPO	35.000	36.500	35.555	35.945	40,350	14,100	100,900	26,220	721,200	189,105	15.10

Brass; snapover separator standard
3/8" balls

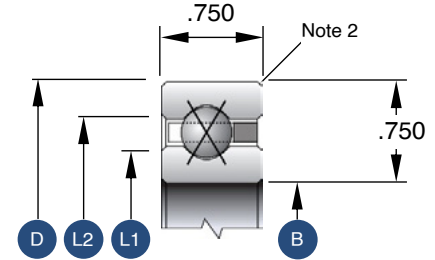

1. Load capacities are not additive
2. The maximum shaft or housing fillet radius that the bearing corners will clear for this series is 0.080"
3. Race Width Tolerance: +0.000 -0.005"

SG SERIES 1" X 1"

SILVERTHIN PART NUMBER	DIMENSIONS IN INCHES				CAPACITIES IN POUNDS						APPROX WEIGHT POUNDS
	BORE DIAMETER "B"	OUTSIDE DIAMETER "D"	LAND DIAMETER "L1"	LAND DIAMETER "L2"	RADIAL		THRUST		MOMENT (LBS-in)		
					STATIC	DYNAMIC	STATIC	DYNAMIC	STATIC	DYNAMIC	
SG040XP0	4.000	6.000	4.742	5.258	8,210	7,980	20,520	11,260	20,520	14,965	3.60
SG042XP0	4.250	6.250	4.992	5.508	8,210	7,915	20,520	11,260	21,550	15,590	3.80
SG045XP0	4.500	6.500	5.242	5.758	8,760	8,205	21,890	11,750	24,080	16,930	4.00
SG047XP0	4.750	6.750	5.492	6.008	9,300	8,485	23,260	12,230	26,740	18,305	4.10
SG050XP0	5.000	7.000	5.742	6.258	9,850	8,760	24,620	12,710	29,550	19,720	4.30
SG055XP0	5.500	7.500	6.242	6.758	10,400	8,980	25,990	13,180	33,790	21,895	4.70
SG060XP0	6.000	8.000	6.742	7.258	11,490	9,505	28,730	14,090	40,220	24,955	5.10
SG065XP0	6.500	8.500	7.242	7.758	12,040	9,715	30,100	14,530	45,140	27,325	5.40
SG070XP0	7.000	9.000	7.742	8.258	13,130	10,210	32,830	15,400	52,530	30,635	5.80
SG080XP0	8.000	10.000	8.742	9.258	14,770	10,880	36,940	16,650	66,480	36,745	6.50
SG090XP0	9.000	11.000	9.742	10.258	16,420	11,525	41,040	17,870	82,080	43,240	7.20
SG100XP0	10.000	12.000	10.742	11.258	18,060	12,145	45,140	19,040	99,320	50,125	7.90
SG110XP0	11.000	13.000	11.742	12.258	19,700	12,740	49,250	20,180	118,200	57,345	8.60
SG120XP0	12.000	14.000	12.742	13.258	21,340	13,315	53,350	21,280	138,700	64,935	9.30
SG140XP0	14.000	16.000	14.742	15.258	24,620	14,405	61,560	23,410	184,700	81,055	10.80
SG160XP0	16.000	18.000	16.742	17.258	27,910	15,425	69,770	25,450	237,200	98,375	12.30
SG180XP0	18.000	20.000	18.742	19.258	31,190	16,385	77,980	27,410	296,300	116,795	13.70
SG200XP0	20.000	22.000	20.742	21.258	34,470	17,295	86,180	29,300	362,000	136,240	15.80
SG250XP0	25.000	27.000	25.742	26.258	42,680	19,360	106,700	33,780	554,900	188,840	19.50
SG300XP0	30.000	32.000	30.742	31.258	50,890	21,200	127,200	37,980	788,800	246,540	23.30
SG350XP0	35.000	37.000	35.742	36.258	59,100	22,845	147,700	41,970	1,064,000	308,525	27.10

Brass; snapover separator standard
1/2" balls

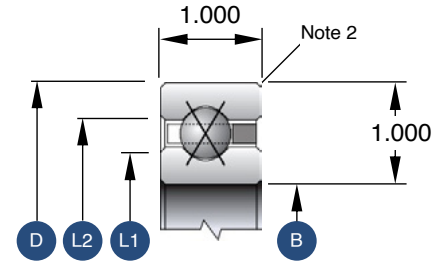

1. Load capacities are not additive
2. The maximum shaft or housing fillet radius that the bearing corners will clear for this series is 0.080"
3. Race Width Tolerance: +0.000 -0.005"

Inch Sealed or Shielded Type C Radial Contact Bearings



The Type C, radial contact ball bearing is designed with deep ball grooves to withstand high loads. Although this bearing is used primarily in applications with radial loads, it can withstand moderate axial loads, reversing axial loads, and moment loads.

Contact Silverthin™ for radial bearing use with combined radial loads, with axial or moment loading, and for limiting speeds and separator selection.

LOAD CONDITION				
RADIAL	AXIAL	MOMENT	REVERSING AXIAL	COMBINED RADIAL-THRUST
Excellent	Good	Good (Light Loading)	Good (Light Loading)	Good

JSHA SERIES 1/4" X 3/16"

SILVERTHIN PART NUMBER	DIMENSIONS IN INCHES				CAPACITIES IN POUNDS		TORQUE MAX NO LOAD (OZ-IN)	APPROX WEIGHT POUNDS
	BORE DIAMETER "B"	OUTSIDE DIAMETER "D"	LAND DIAMETER "L1"	LAND DIAMETER "L2"	RADIAL			
					STATIC	DYNAMIC		
JSHA10CLO	1.000	1.375	1.140	1.235	290	190	5	0.03
JSHA15CLO	1.500	1.875	1.640	1.735	400	225	5	0.04
JSHA17CLO	1.750	2.125	1.890	1.985	460	240	6	0.05

Nylon; one piece snapover separator standard 3/32" balls

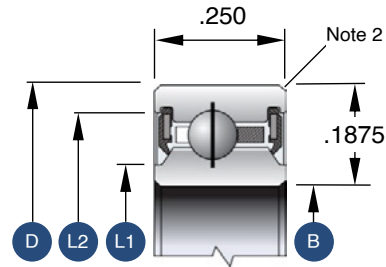

1. Load capacities are not additive
2. The maximum shaft or housing fillet radius that the bearing corners will clear for this series is 0.015"
3. Race Width Tolerance: +0.000 -0.005"



JSA SERIES 1/4" X 1/4"

SILVERTHIN PART NUMBER	DIMENSIONS IN INCHES				CAPACITIES IN POUNDS		TORQUE MAX NO LOAD (OZ-IN)	APPROX WEIGHT POUNDS
	BORE DIAMETER "B"	OUTSIDE DIAMETER "D"	LAND DIAMETER "L1"	LAND DIAMETER "L2"	RADIAL			
					STATIC	DYNAMIC		
JSA020CP0	2.000	2.500	2.186	2.314	680	395	6	0.1
JSA025CP0	2.500	3.000	2.686	2.814	830	440	8	0.12
JSA030CP0	3.000	3.500	3.186	3.314	990	485	12	0.14
JSA035CP0	3.500	4.000	3.686	3.814	1,140	530	16	0.17
JSA040CP0	4.000	4.500	4.186	4.314	1,290	570	20	0.19
JSA042CP0	4.250	4.750	4.436	4.564	1,370	590	24	0.2
JSA045CP0	4.500	5.000	4.686	4.814	1,440	610	28	0.21
JSA047CP0	4.750	5.250	4.936	5.064	1,520	630	32	0.22
JSA050CP0	5.000	5.500	5.186	5.314	1,590	650	36	0.23
JSA055CP0	5.500	6.000	5.686	5.814	1,750	685	44	0.25
JSA060CP0	6.000	6.500	6.186	6.314	1,900	720	52	0.28
JSA065CP0	6.500	7.000	6.686	6.814	2,050	755	61	0.3

Brass; snapover separator standard 1/8" balls

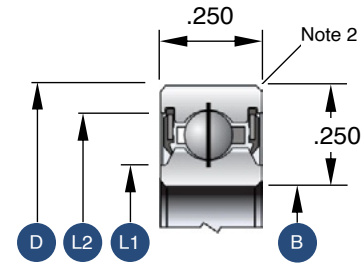

1. Load capacities are not additive
2. The maximum shaft or housing fillet radius that the bearing corners will clear for this series is 0.025"
3. Race Width Tolerance: +0.000-0.005"



JSB SERIES 5/16" X 5/16"

SILVERTHIN PART NUMBER	DIMENSIONS IN INCHES				CAPACITIES IN POUNDS		TORQUE MAX NO LOAD (OZ-IN)	APPROX WEIGHT POUNDS
	BORE DIAMETER "B"	OUTSIDE DIAMETER "D"	LAND DIAMETER "L1"	LAND DIAMETER "L2"	RADIAL			
					STATIC	DYNAMIC		
JSB020CPO	2.000	2.625	2.231	2.393	930	575	6	0.16
JSB025CPO	2.500	3.125	2.731	2.893	1,140	645	8	0.19
JSB030CPO	3.000	3.625	3.231	3.393	1,340	705	12	0.24
JSB035CPO	3.500	4.125	3.731	3.893	1,540	765	16	0.29
JSB040CPO	4.000	4.625	4.231	4.393	1,750	825	20	0.3
JSB042CPO	4.250	4.875	4.481	4.643	1,830	845	24	0.31
JSB045CPO	4.500	5.125	4.731	4.893	1,950	880	28	0.33
JSB047CPO	4.750	5.375	4.981	5.143	2,030	900	32	0.34
JSB050CPO	5.000	5.625	5.231	5.393	2,150	935	36	0.38
JSB055CPO	5.500	6.125	5.731	5.893	2,360	985	44	0.41
JSB060CPO	6.000	6.625	6.231	6.393	2,560	1,035	52	0.44
JSB065CPO	6.500	7.125	6.731	6.893	2,760	1,080	61	0.47

Brass; snapover separator standard
5/32" balls

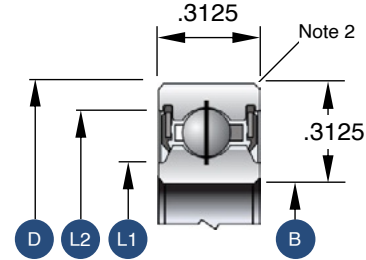

1. Load capacities are not additive
2. The maximum shaft or housing fillet radius that the bearing corners will clear for this series is 0.040"
3. Race Width Tolerance: +0.000 -0.005"



Inch Sealed or Shielded Type C Radial Contact Bearings



JSU SERIES 1/2" X 3/8"

SILVERTHIN PART NUMBER	DIMENSIONS IN INCHES				CAPACITIES IN POUNDS		TORQUE MAX NO LOAD (OZ-IN)	APPROX WEIGHT POUNDS
	BORE DIAMETER "B"	OUTSIDE DIAMETER "D"	LAND DIAMETER "L1"	LAND DIAMETER "L2"	RADIAL			
					STATIC	DYNAMIC		
JSU040CP0	4.000	4.750	4.277	4.473	2,100	1,075	46	0.55
JSU042CP0	4.250	5.000	4.527	4.723	2,220	1,110	50	0.58
JSU045CP0	4.500	5.250	4.777	4.973	2,340	1,145	56	0.61
JSU047CP0	4.750	5.500	5.027	5.223	2,460	1,175	62	0.65
JSU050CP0	5.000	5.750	5.277	5.473	2,590	1,210	70	0.68
JSU055CP0	5.500	6.250	5.777	5.973	2,830	1,275	82	0.74
JSU060CP0	6.000	6.750	6.277	6.473	3,070	1,335	98	0.81
JSU065CP0	6.500	7.250	6.777	6.973	3,310	1,395	112	0.87
JSU070CP0	7.000	7.750	7.277	7.473	3,550	1,455	130	0.93
JSU075CP0	7.500	8.250	7.777	7.973	3,790	1,515	146	0.99
JSU080CP0	8.000	8.750	8.277	8.473	4,030	1,570	166	1.06
JSU090CP0	9.000	9.750	9.277	9.473	4,510	1,680	208	1.18
JSU100CP0	10.000	10.750	10.277	10.473	4,990	1,780	256	1.31
JSU110CP0	11.000	11.750	11.277	11.473	5,470	1,880	308	1.43
JSU120CP0	12.000	12.750	12.277	12.473	5,950	1,975	364	1.56

Brass; snapover separator standard
3/16" balls

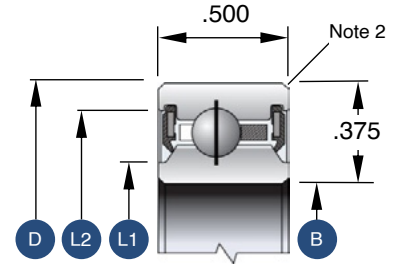

1. Load capacities are not additive
2. The maximum shaft or housing fillet radius that the bearing corners will clear for this series is 0.040"
3. Race Width Tolerance: +0.000 -0.005"

Inch Sealed or Shielded Type X 4-Point Contact Bearings



The Type X, or 4-point contact, ball bearing is ideal for moment loading. Type X bearings are designed with gothic arch raceways creating 4 contact points between the balls and the raceways. This design is excellent for moment loading and reversing axial loading.

The Type X bearing can be used for other light loading conditions, but is not recommended in place of the C- or Type A bearing for pure radial loads. Contact Silverthin™ for information on combined load and limiting speeds.

LOAD CONDITION				
RADIAL	AXIAL	MOMENT	REVERSING AXIAL	COMBINED RADIAL-THRUST
Poor	Good	Excellent	Excellent	Poor

JSHA SERIES 1/4" X 3/16"

SILVERTHIN PART NUMBER	DIMENSIONS IN INCHES				CAPACITIES IN POUNDS						TORQUE MAX NO LOAD (OZ-IN)	APPROX WEIGHT POUNDS
	BORE DIAMETER "B"	OUTSIDE DIAMETER "D"	LAND DIAMETER "L1"	LAND DIAMETER "L2"	RADIAL		THRUST		MOMENT (LBS-IN)			
					STATIC	DYNAMIC	STATIC	DYNAMIC	STATIC	DYNAMIC		
JSHA10XLO	1.000	1.375	1.140	1.235	290	245	730	370	170	110	6	0.03
JSHA15XLO	1.500	1.875	1.640	1.735	400	295	1,000	460	340	185	5	0.04
JSHA17XLO	1.750	2.125	1.890	1.985	460	320	1,140	500	440	230	6	0.05

Nylon; one piece snapover separator standard 3/32" balls

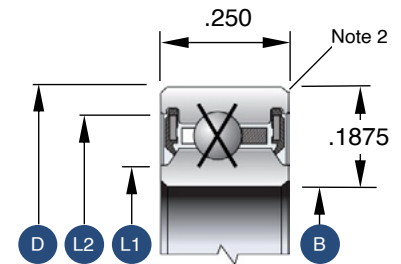

1. Load capacities are not additive
2. The maximum shaft or housing fillet radius that the bearing corners will clear for this series is 0.015"
3. Race Width Tolerance: +0.000 -0.005"

Inch Sealed or Shielded Type X 4-Point Contact Bearings



JSA SERIES 1/4" X 1/4"

SILVERTHIN PART NUMBER	DIMENSIONS IN INCHES				CAPACITIES IN POUNDS						TORQUE MAX NO LOAD (OZ-IN)	APPROX WEIGHT POUNDS
	BORE DIAMETER "B"	OUTSIDE DIAMETER "D"	LAND DIAMETER "L1"	LAND DIAMETER "L2"	RADIAL		THRUST		MOMENT (LBS-in)			
					STATIC	DYNAMIC	STATIC	DYNAMIC	STATIC	DYNAMIC		
JSA020XP0	2.000	2.500	2.186	2.314	680	515	1,710	790	770	435	6	0.10
JSA025XP0	2.500	3.000	2.686	2.814	830	585	2,090	910	1,150	600	8	0.13
JSA030XP0	3.000	3.500	3.186	3.314	990	645	2,470	1,010	1,600	785	12	0.15
JSA035XP0	3.500	4.000	3.686	3.814	1,140	700	2,850	1,110	2,130	985	16	0.18
JSA040XP0	4.000	4.500	4.186	4.314	1,290	755	3,220	1,210	2,740	1,205	20	0.19
JSA042XP0	4.250	4.750	4.436	4.564	1,370	785	3,410	1,260	3,070	1,320	24	0.20
JSA045XP0	4.500	5.000	4.686	4.814	1,440	810	3,600	1,310	3,420	1,440	28	0.22
JSA047XP0	4.750	5.250	4.936	5.064	1,520	835	3,790	1,350	3,790	1,565	32	0.23
JSA050XP0	5.000	5.500	5.186	5.314	1,590	860	3,980	1,400	4,180	1,695	36	0.24
JSA055XP0	5.500	6.000	5.686	5.814	1,750	910	4,360	1,480	5,020	1,960	44	0.25
JSA060XP0	6.000	6.500	6.186	6.314	1,900	955	4,740	1,570	5,930	2,240	52	0.28
JSA065XP0	6.500	7.000	6.686	6.814	2,050	1,000	5,120	1,650	6,910	2,535	61	0.30

Brass; snapover separator standard
1/8" balls

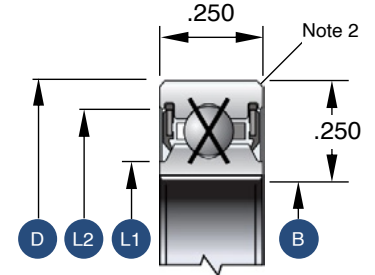

1. Load capacities are not additive
2. The maximum shaft or housing fillet radius that the bearing corners will clear for this series is 0.025"
3. Race Width Tolerance: +0.000 -0.005"



Inch Sealed or Shielded Type X 4-Point Contact Bearings



JSB SERIES 5/16" X 5/16"

SILVERTHIN PART NUMBER	DIMENSIONS IN INCHES				CAPACITIES IN POUNDS						TORQUE MAX NO LOAD (OZ-IN)	APPROX WEIGHT POUNDS
	BORE DIAMETER "B"	OUTSIDE DIAMETER "D"	LAND DIAMETER "L1"	LAND DIAMETER "L2"	RADIAL		THRUST		MOMENT (LBS-in)			
					STATIC	DYNAMIC	STATIC	DYNAMIC	STATIC	DYNAMIC		
JSB020XPO	2.000	2.625	2.231	2.393	930	760	2,340	1,130	1,080	660	6	0.16
JSB025XPO	2.500	3.125	2.731	2.893	1,140	850	2,840	1,290	1,600	895	8	0.19
JSB030XPO	3.000	3.625	3.231	3.393	1,340	935	3,350	1,440	2,220	1,160	12	0.24
JSB035XPO	3.500	4.125	3.731	3.893	1,540	1,015	3,860	1,590	2,940	1,450	16	0.29
JSB040XPO	4.000	4.625	4.231	4.393	1,750	1,090	4,370	1,720	3,770	1,765	20	0.30
JSB042XPO	4.250	4.875	4.481	4.643	1,830	1,120	4,570	1,780	4,170	1,915	24	0.31
JSB045XPO	4.500	5.125	4.731	4.893	1,950	1,165	4,880	1,850	4,690	2,105	28	0.33
JSB047XPO	4.750	5.375	4.981	5.143	2,030	1,195	5,080	1,900	5,140	2,265	32	0.34
JSB050XPO	5.000	5.625	5.231	5.393	2,150	1,235	5,380	1,980	5,720	2,465	36	0.38
JSB055XPO	5.500	6.125	5.731	5.893	2,360	1,305	5,890	2,100	6,850	2,845	44	0.41
JSB060XPO	6.000	6.625	6.231	6.393	2,560	1,370	6,400	2,220	8,080	3,245	52	0.44
JSB065XPO	6.500	7.125	6.731	6.893	2,760	1,435	6,910	2,340	9,410	3,670	61	0.47

Brass; snapover separator standard
5/32" balls

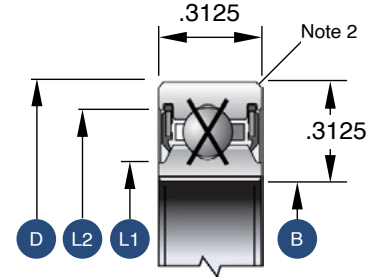

1. Load capacities are not additive
2. The maximum shaft or housing fillet radius that the bearing corners will clear for this series is 0.040"
3. Race Width Tolerance: +0.000 -0.005"



Inch Sealed or Shielded Type X 4-Point Contact Bearings



JSU SERIES 1/2" X 3/8"

SILVERTHIN PART NUMBER	DIMENSIONS IN INCHES				CAPACITIES IN POUNDS						TORQUE MAX NO LOAD (OZ-IN)	APPROX WEIGHT POUNDS
	BORE DIAMETER "B"	OUTSIDE DIAMETER "D"	LAND DIAMETER "L1"	LAND DIAMETER "L2"	RADIAL		THRUST		MOMENT (LBS-in)			
					STATIC	DYNAMIC	STATIC	DYNAMIC	STATIC	DYNAMIC		
JSU040XPO	4.000	4.750	4.277	4.473	2,100	1,415	5,260	2,210	4,600	2,325	46	0.55
JSU042XPO	4.250	5.000	4.527	4.723	2,220	1,465	5,560	2,290	5,140	2,540	50	0.58
JSU045XPO	4.500	5.250	4.777	4.973	2,340	1,510	5,860	2,380	5,710	2,760	56	0.61
JSU047XPO	4.750	5.500	5.027	5.223	2,460	1,555	6,160	2,460	6,320	2,990	62	0.65
JSU050XPO	5.000	5.750	5.277	5.473	2,590	1,600	6,460	2,540	6,950	3,225	70	0.68
JSU055XPO	5.500	6.250	5.777	5.973	2,830	1,685	7,060	2,690	8,300	3,715	82	0.74
JSU060XPO	6.000	6.750	6.277	6.473	3,070	1,770	7,660	2,840	9,770	4,235	98	0.81
JSU065XPO	6.500	7.250	6.777	6.973	3,310	1,850	8,270	2,990	11,370	4,775	112	0.87
JSU070XPO	7.000	7.750	7.277	7.473	3,550	1,930	8,870	3,130	13,080	5,340	130	0.93
JSU075XPO	7.500	8.250	7.777	7.973	3,790	2,005	9,470	3,270	14,910	5,930	146	0.99
JSU080XPO	8.000	8.750	8.277	8.473	4,030	2,080	10,070	3,410	16,870	6,540	166	1.06
JSU090XPO	9.000	9.750	9.277	9.473	4,510	2,225	11,270	3,670	21,130	7,830	208	1.18
JSU100XPO	10.000	10.750	10.277	10.473	4,990	2,365	12,470	3,930	25,880	9,200	256	1.31
JSU110XPO	11.000	11.750	11.277	11.473	5,470	2,495	13,680	4,180	31,110	10,650	308	1.43
JSU120XPO	12.000	12.750	12.277	12.473	5,950	2,620	14,880	4,420	36,830	12,175	364	1.56

Brass; snapover separator standard
3/16" balls

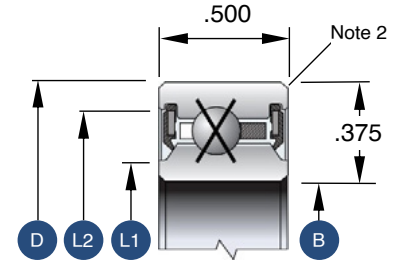

1. Load capacities are not additive
2. The maximum shaft or housing fillet radius that the bearing corners will clear for this series is 0.040"
3. Race Width Tolerance: +0.000
-0.005"

Inch Duplex Type B

Back-to-Back Paired Angular Contact Bearings



Two Type A bearings are often used as a duplex pair. This design is excellent for moment loading and reversing axial loading.

LOAD CONDITION				
RADIAL	AXIAL	MOMENT	REVERSING AXIAL	COMBINED RADIAL-THRUST
Very Good	Very Good	Very Good	Very Good	Good

SAA SERIES 3/16" X 3/16"

SILVERTHIN PART NUMBER	DIMENSIONS IN INCHES				CAPACITIES IN POUNDS						APPROX WEIGHT POUNDS
	BORE DIAMETER "B"	OUTSIDE DIAMETER "D"	LAND DIAMETER "L1"	LAND DIAMETER "L3"	RADIAL		THRUST		MOMENT (LBS-in)		
					STATIC	DYNAMIC	STATIC	DYNAMIC	STATIC	DYNAMIC	
SAA10BGO	1.000	1.375	1.140	1.274	550	310	970	450	295	170	0.05
SAA15BGO	1.500	1.875	1.640	1.774	780	390	1,380	560	555	275	0.08
SAA17BGO	1.7500	2.125	1.890	2.024	860	400	1,520	600	690	330	0.09

Nylon; circular pocket separator standard 3/32" balls

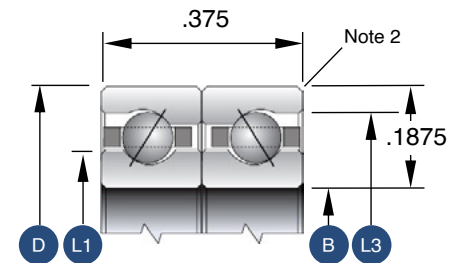

1. Load capacities are not additive
2. The maximum shaft or housing fillet radius that the bearing corners will clear for this series is 0.015"
3. Race Width Tolerance: +0.000 -0.010"

Inch Duplex Type B

Back-to-Back Paired Angular Contact Bearings



SA SERIES 1/4" X 1/4"

SILVERTHIN PART NUMBER	DIMENSIONS IN INCHES				CAPACITIES IN POUNDS						APPROX WEIGHT POUNDS
	BORE DIAMETER "B"	OUTSIDE DIAMETER "D"	LAND DIAMETER "L1"	LAND DIAMETER "L3"	RADIAL		THRUST		MOMENT (LBS-in)		
					STATIC	DYNAMIC	STATIC	DYNAMIC	STATIC	DYNAMIC	
SA020BRO	2.000	2.500	2.186	2.369	1,280	650	2,280	960	1,220	630	0.20
SA025BRO	2.500	3.000	2.686	2.869	1,560	740	2,780	1,100	1,770	845	0.26
SA030BRO	3.000	3.500	3.186	3.367	1,850	820	3,290	1,230	2,420	1,080	0.30
SA035BRO	3.500	4.000	3.686	3.867	2,120	890	3,790	1,350	3,175	1,335	0.36
SA040BRO	4.000	4.500	4.186	4.367	2,420	960	4,300	1,470	4,025	1,610	0.38
SA042BRO	4.250	4.750	4.436	4.615	2,560	990	4,550	1,530	4,490	1,755	0.40
SA045BRO	4.500	5.000	4.686	4.865	2,690	1,030	4,810	1,580	4,980	1,905	0.44
SA047BRO	4.750	5.250	4.936	5.115	2,840	1,060	5,060	1,640	5,495	2,060	0.46
SA050BRO	5.000	5.500	5.186	5.365	2,990	1,090	5,310	1,690	6,035	2,220	0.48
SA055BRO	5.500	6.000	5.686	5.863	3,280	1,160	5,820	1,800	7,195	2,550	0.50
SA060BRO	6.000	6.500	6.186	6.363	3,550	1,210	6,320	1,900	8,450	2,900	0.56
SA065BRO	6.500	7.000	6.686	6.861	3,850	1,280	6,830	2,000	9,810	3,265	0.60
SA070BRO	7.000	7.500	7.186	7.361	4,120	1,340	7,340	2,100	11,270	3,650	0.62
SA075BRO	7.500	8.000	7.686	7.861	4,420	1,380	7,840	2,190	12,835	4,050	0.68
SA080BRO	8.000	8.500	8.186	8.359	4,690	1,440	8,350	2,280	14,495	4,465	0.76
SA090BRO	9.000	9.500	9.186	9.357	5,260	1,550	9,360	2,470	18,125	5,335	0.88
SA100BRO	10.000	10.500	10.186	10.355	5,830	1,640	10,370	2,640	22,155	6,265	1.00
SA110BRO	11.000	11.500	11.186	11.353	6,400	1,730	11,380	2,810	26,595	7,240	1.04
SA120BRO	12.000	12.500	12.186	12.349	6,970	1,830	12,390	2,970	31,440	8,265	1.12

Brass; one piece pocket separator
standard 1/8" balls

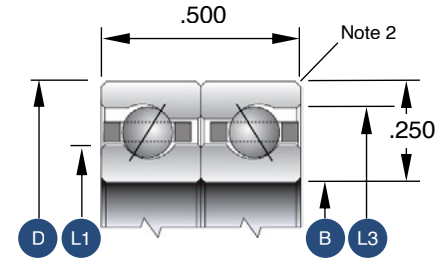

1. Load capacities are not additive
2. The maximum shaft or housing fillet radius that the bearing corners will clear for this series is 0.025"
3. Race Width Tolerance: +0.000 -0.010"

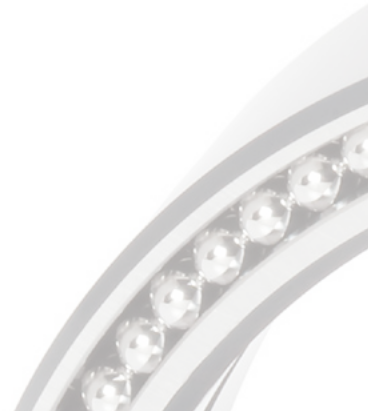

Inch Duplex Type B

Back-to-Back Paired Angular Contact Bearings



SB SERIES 5/16" X 5/16"

SILVERTHIN PART NUMBER	DIMENSIONS IN INCHES				CAPACITIES IN POUNDS						APPROX WEIGHT POUNDS
	BORE DIAMETER "B"	OUTSIDE DIAMETER "D"	LAND DIAMETER "L1"	LAND DIAMETER "L3"	RADIAL		THRUST		MOMENT (LBS-in)		
					STATIC	DYNAMIC	STATIC	DYNAMIC	STATIC	DYNAMIC	
SB020BRO	2.000	2.625	2.231	2.464	1,770	970	3,150	1,380	1,775	975	0.32
SB025BRO	2.500	3.125	2.731	2.964	2,170	1,090	3,860	1,590	2,560	1,300	0.38
SB030BRO	3.000	3.625	3.231	3.462	2,510	1,190	4,470	1,750	3,475	1,655	0.48
SB035BRO	3.500	4.125	3.731	3.962	2,900	1,300	5,180	1,930	4,525	2,030	0.58
SB040BRO	4.000	4.625	4.231	4.460	3,310	1,400	5,890	2,100	5,710	2,435	0.60
SB042BRO	4.250	4.875	4.481	4.710	3,490	1,440	6,200	2,170	6,355	2,645	0.62
SB045BRO	4.500	5.125	4.731	4.960	3,650	1,480	6,500	2,240	7,035	2,865	0.66
SB047BRO	4.750	5.375	4.981	5.210	3,880	1,540	6,910	2,340	7,745	3,090	0.68
SB050BRO	5.000	5.625	5.231	5.460	4,060	1,580	7,210	2,410	8,490	3,320	0.76
SB055BRO	5.500	6.125	5.731	5.958	4,450	1,680	7,920	2,560	10,085	3,795	0.82
SB060BRO	6.000	6.625	6.231	6.458	4,850	1,770	8,630	2,710	11,815	4,300	0.88
SB065BRO	6.500	7.125	6.731	6.958	5,200	1,830	9,240	2,840	13,680	4,825	0.94
SB070BRO	7.000	7.625	7.231	7.456	5,600	1,920	9,960	2,980	15,680	5,375	1.00
SB075BRO	7.500	8.125	7.731	7.955	6,010	2,000	10,670	3,120	17,815	5,945	1.06
SB080BRO	8.000	8.625	8.231	8.453	6,400	2,080	11,380	3,260	20,090	6,535	1.14
SB090BRO	9.000	9.625	9.231	9.451	7,150	2,220	12,700	3,510	25,045	7,785	1.32
SB100BRO	10.000	10.625	10.231	10.449	7,940	2,370	14,120	3,760	30,540	9,115	1.46
SB110BRO	11.000	11.625	11.231	11.447	8,690	2,500	15,440	4,000	36,585	10,525	1.50
SB120BRO	12.000	12.625	12.231	12.445	9,490	2,640	16,860	4,240	43,180	12,005	1.66
SB140BRO	14.000	14.625	14.231	14.439	10,980	2,860	19,500	4,670	58,005	15,175	2.10
SB160BRO	16.000	16.625	16.231	16.433	12,520	3,090	22,250	5,100	75,020	18,590	2.40
SB180BRO	18.000	18.625	18.231	18.425	14,070	3,310	24,990	5,510	94,240	22,220	2.70
SB200BRO	20.000	20.625	20.231	20.416	15,610	3,510	27,730	5,900	115,660	26,030	3.00

Brass; one piece pocket separator
standard 5/32" balls

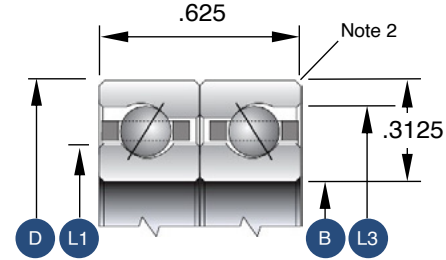

1. Load capacities are not additive
2. The maximum shaft or housing fillet radius that the bearing corners will clear for this series is 0.040"
3. Race Width Tolerance: +0.000 -0.010"

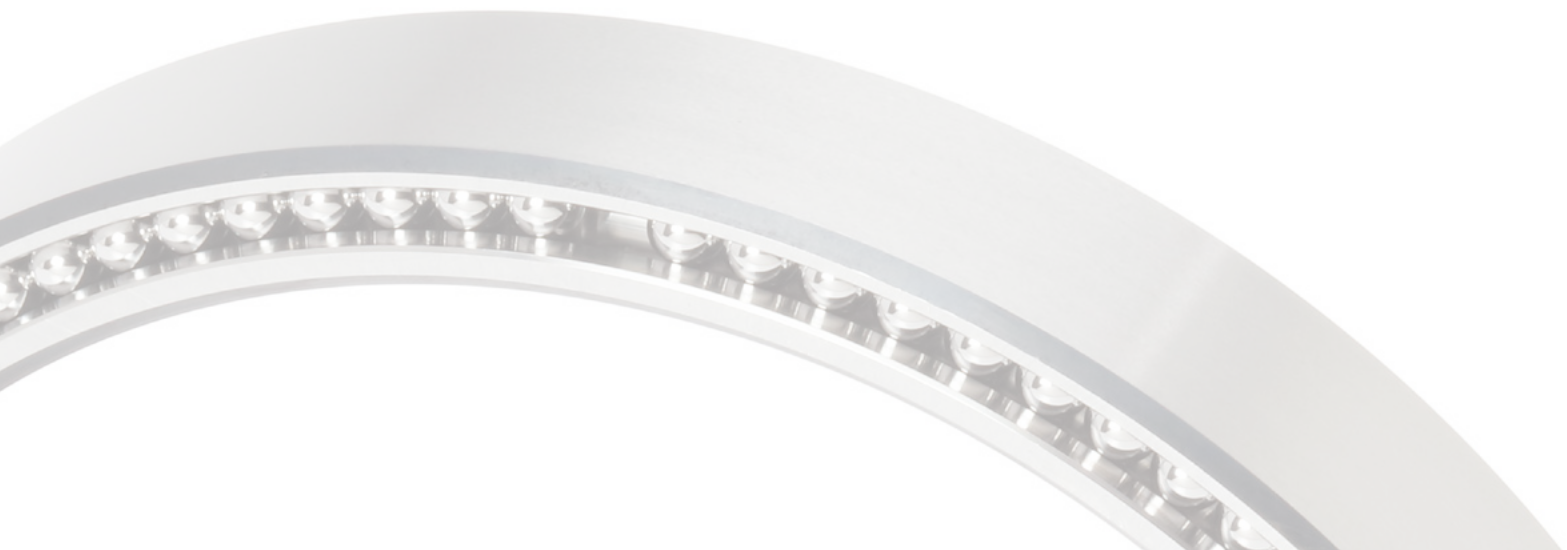

Inch Duplex Type B

Back-to-Back Paired Angular Contact Bearings



SC SERIES 3/8" X 3/8"

SILVERTHIN PART NUMBER	DIMENSIONS IN INCHES				CAPACITIES IN POUNDS						APPROX WEIGHT POUNDS
	BORE DIAMETER "B"	OUTSIDE DIAMETER "D"	LAND DIAMETER "L1"	LAND DIAMETER "L3"	RADIAL		THRUST		MOMENT (LBS-in)		
					STATIC	DYNAMIC	STATIC	DYNAMIC	STATIC	DYNAMIC	
SC040BRO	4.000	4.750	4.277	4.554	4,140	1,870	7,360	2,770	7,410	3,340	0.90
SC042BRO	4.250	5.000	4.527	4.804	4,400	1,940	7,820	2,880	8,240	3,630	0.94
SC045BRO	4.500	5.250	4.777	5.052	4,640	2,000	8,270	2,990	9,105	3,930	0.96
SC047BRO	4.750	5.500	5.027	5.302	4,900	2,070	8,720	3,100	10,020	4,240	1.00
SC050BRO	5.000	5.750	5.277	5.552	5,160	2,130	9,170	3,200	10,975	4,555	1.16
SC055BRO	5.500	6.250	5.777	6.052	5,590	2,230	9,920	3,370	13,010	5,210	1.18
SC060BRO	6.000	6.750	6.277	6.550	6,090	2,350	10,820	3,580	15,220	5,890	1.26
SC065BRO	6.500	7.250	6.777	7.050	6,590	2,470	11,720	3,770	17,595	6,600	1.36
SC070BRO	7.000	7.750	7.277	7.550	7,020	2,550	12,470	3,930	20,145	7,340	1.46
SC075BRO	7.500	8.250	7.777	8.048	7,520	2,660	13,380	4,120	22,865	8,105	1.56
SC080BRO	8.000	8.750	8.277	8.548	8,040	2,770	14,280	4,300	25,755	8,895	1.68
SC090BRO	9.000	9.750	9.277	9.546	8,970	2,950	15,930	4,630	32,050	10,565	1.88
SC100BRO	10.000	10.750	10.277	10.544	9,970	3,150	17,730	4,970	39,020	12,330	2.12
SC110BRO	11.000	11.750	11.277	11.542	10,920	3,320	19,390	5,280	46,680	14,200	2.32
SC120BRO	12.000	12.750	12.277	12.540	11,840	3,480	21,040	5,570	55,020	16,160	2.50
SC140BRO	14.000	14.750	14.277	14.535	13,790	3,810	24,500	6,170	73,745	20,360	3.04
SC160BRO	16.000	16.750	16.277	16.529	15,730	4,110	27,950	6,730	95,200	24,900	3.46
SC180BRO	18.000	18.750	18.277	18.523	17,680	4,390	31,410	7,280	119,380	29,755	3.88
SC200BRO	20.000	20.750	20.277	20.517	19,540	4,650	34,720	7,780	146,290	34,885	4.32
SC250BRO	25.000	25.750	25.277	25.500	24,210	5,250	43,280	9,010	225,490	48,770	5.38
SC300BRO	30.000	30.750	30.277	30.484	29,180	5,780	51,850	10,160	321,730	63,785	6.42

Brass; one piece pocket separator
standard 3/16" ball

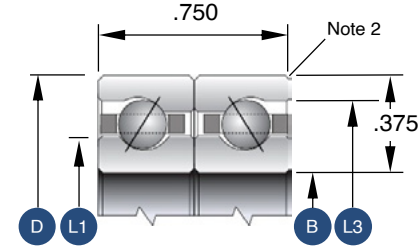

1. Load capacities are not additive
2. The maximum shaft or housing fillet radius that the bearing corners will clear for this series is 0.040"
3. Race Width Tolerance: +0.000 -0.010"

Inch Duplex Type B

Back-to-Back Paired Angular Contact Bearings



SD SERIES 1/2" X 1/2"

SILVERTHIN PART NUMBER	DIMENSIONS IN INCHES				CAPACITIES IN POUNDS						APPROX WEIGHT POUNDS
	BORE DIAMETER "B"	OUTSIDE DIAMETER "D"	LAND DIAMETER "L1"	LAND DIAMETER "L2"	RADIAL		THRUST		MOMENT (LBS-in)		
					STATIC	DYNAMIC	STATIC	DYNAMIC	STATIC	DYNAMIC	
SD040BRO	4.000	5.000	4.370	4.741	5,760	2,950	10,260	4,260	11,015	5,620	1.56
SD042BRO	4.250	5.250	4.620	4.991	6,090	3,040	10,830	4,420	12,165	6,075	1.66
SD045BRO	4.500	5.500	4.870	5.241	6,410	3,130	11,400	4,570	13,380	6,545	1.76
SD047BRO	4.750	5.750	5.120	5.490	6,740	3,220	11,970	4,720	14,645	7,020	1.88
SD050BRO	5.000	6.000	5.370	5.740	7,050	3,310	12,540	4,870	15,970	7,510	2.00
SD055BRO	5.500	6.500	5.870	6.238	7,700	3,480	13,680	5,160	18,790	8,525	2.12
SD060BRO	6.000	7.000	6.370	6.738	8,330	3,640	14,820	5,440	21,835	9,580	2.32
SD065BRO	6.500	7.500	6.870	7.236	8,980	3,810	15,960	5,720	25,110	10,675	2.44
SD070BRO	7.000	8.000	7.370	7.736	9,620	3,960	17,100	5,990	28,615	11,815	2.62
SD075BRO	7.500	8.500	7.870	8.236	10,270	4,110	18,240	6,250	32,345	12,995	2.82
SD080BRO	8.000	9.000	8.370	8.734	10,900	4,260	19,380	6,510	36,305	14,215	3.06
SD090BRO	9.000	10.000	9.370	9.732	12,180	4,550	21,660	7,010	44,910	16,770	3.44
SD100BRO	10.000	11.000	10.370	10.732	13,470	4,820	23,940	7,500	54,425	19,485	3.76
SD110BRO	11.000	12.000	11.370	11.730	14,750	5,090	26,220	7,960	64,850	22,340	4.12
SD120BRO	12.000	13.000	12.370	12.728	16,030	5,340	28,500	8,420	76,190	25,345	4.50
SD140BRO	14.000	15.000	14.370	14.724	18,600	5,810	33,060	9,290	101,605	31,755	5.46
SD160BRO	16.000	17.000	16.370	16.718	21,170	6,260	37,620	10,130	130,665	38,670	6.20
SD180BRO	18.000	19.000	18.370	18.712	23,740	6,680	42,180	10,930	163,375	46,055	6.96
SD200BRO	20.000	21.000	20.370	20.705	26,300	7,070	46,740	11,710	199,730	53,860	7.70
SD250BRO	25.000	26.000	25.370	25.688	27,590	7,260	49,020	12,085	306,585	74,940	9.58
SD300BRO	30.000	31.000	30.370	30.672	39,140	8,760	69,540	15,260	436,240	97,735	11.46

Brass; one piece pocket separator
standard 1/4" balls

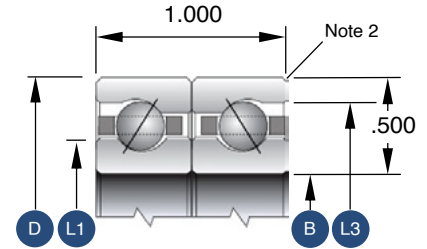

1. Load capacities are not additive
2. The maximum shaft or housing fillet radius that the bearing corners will clear for this series is 0.060"
3. Race Width Tolerance: +0.000 -0.010"

Inch Duplex Type B

Back-to-Back Paired Angular Contact Bearings



SF SERIES 3/4" X 3/4"

SILVERTHIN PART NUMBER	DIMENSIONS IN INCHES				CAPACITIES IN POUNDS						APPROX WEIGHT POUNDS
	BORE DIAMETER "B"	OUTSIDE DIAMETER "D"	LAND DIAMETER "L1"	LAND DIAMETER "L3"	RADIAL		THRUST		MOMENT (LBS-in)		
					STATIC	DYNAMIC	STATIC	DYNAMIC	STATIC	DYNAMIC	
SF040BRO	4.000	5.500	4.555	5.115	10,310	6,060	18,340	8,420	22,110	12,910	3.80
SF042BRO	4.250	5.750	4.805	5.365	10,720	6,180	19,050	8,630	24,265	13,875	4.00
SF045BRO	4.500	6.000	5.060	5.615	11,520	6,440	20,460	9,050	26,515	14,855	4.20
SF047BRO	4.750	6.250	5.305	5.865	11,910	6,550	21,160	9,260	28,860	15,855	4.40
SF050BRO	5.000	6.500	5.555	6.115	12,300	6,660	21,870	9,460	31,300	16,875	4.60
SF055BRO	5.500	7.000	6.055	6.613	13,500	7,020	23,980	10,060	36,475	18,970	5.00
SF060BRO	6.000	7.500	6.555	7.113	14,690	7,360	26,100	10,650	42,030	21,140	5.40
SF065BRO	6.500	8.000	7.055	7.613	15,870	7,690	28,220	11,220	47,970	23,385	5.80
SF070BRO	7.000	8.500	7.555	8.113	17,070	8,010	30,330	11,770	54,300	25,700	6.40
SF075BRO	7.500	9.000	8.055	8.610	17,870	8,200	31,740	12,130	61,010	28,085	6.80
SF080BRO	8.000	9.500	8.555	9.110	19,060	8,510	33,860	12,670	68,110	30,545	7.00
SF090BRO	9.000	10.500	9.555	10.108	21,430	9,110	38,090	13,700	83,465	35,665	7.80
SF100BRO	10.000	11.500	10.555	11.106	23,430	9,570	41,620	14,530	100,370	41,060	8.60
SF110BRO	11.000	12.500	11.555	12.106	25,800	10,110	45,850	15,500	118,825	46,715	9.60
SF120BRO	12.000	13.500	12.555	13.104	27,780	10,530	49,380	16,290	138,830	52,630	10.40
SF140BRO	14.000	15.500	14.555	15.102	32,150	11,440	57,140	17,950	183,525	65,205	12.00
SF160BRO	16.000	17.500	16.555	17.098	36,530	12,290	64,890	19,540	234,470	78,725	14.20
SF180BRO	18.000	19.500	18.555	19.096	41,290	13,170	73,360	21,210	291,690	93,130	15.80
SF200BRO	20.000	21.500	20.555	21.092	45,660	13,910	81,120	22,680	355,215	108,365	17.80
SF250BRO	25.000	26.500	25.555	26.085	56,380	15,570	100,200	26,100	541,745	149,725	21.80
SF300BRO	30.000	31.500	30.555	31.075	67,500	17,110	119,900	29,430	768,185	195,050	26.00
SF350BRO	35.000	36.500	35.555	36.064	78,610	18,490	139,700	32,580	1,034,910	243,450	30.20

Brass; one piece pocket separator
standard 3/8" balls

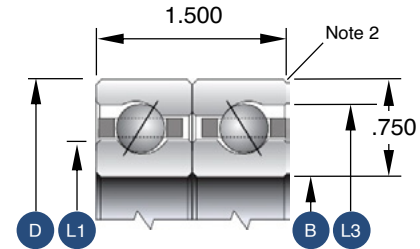

1. Load capacities are not additive
2. The maximum shaft or housing fillet radius that the bearing corners will clear for this series is 0.080"
3. Race Width Tolerance: +0.000 -0.010"

Inch Duplex Type B

Back-to-Back Paired Angular Contact Bearings



SG SERIES 1" X 1"

SILVERTHIN PART NUMBER	DIMENSIONS IN INCHES				CAPACITIES IN POUNDS						APPROX WEIGHT POUNDS
	BORE DIAMETER "B"	OUTSIDE DIAMETER "D"	LAND DIAMETER "L1"	LAND DIAMETER "L3"	RADIAL		THRUST		MOMENT (LBS-in)		
					STATIC	DYNAMIC	STATIC	DYNAMIC	STATIC	DYNAMIC	
SG040BRO	4.000	6.000	4.742	5.491	15,400	10,200	27,360	13,630	36,840	24,260	7.20
SG042BRO	4.250	6.250	4.992	5.741	16,160	10,460	28,730	14,090	40,115	25,855	7.60
SG045BRO	4.500	6.500	5.242	5.989	16,940	10,660	30,100	14,530	43,530	27,480	8.00
SG047BRO	4.750	6.750	5.492	6.239	17,710	10,960	31,460	14,970	47,085	29,135	8.20
SG050BRO	5.000	7.000	5.742	6.489	18,470	11,200	32,830	15,400	50,770	30,820	8.60
SG055BRO	5.500	7.500	6.242	6.989	20,020	11,680	35,570	16,240	58,560	34,280	9.40
SG060BRO	6.000	8.000	6.742	7.489	21,560	12,150	38,300	17,060	66,895	37,850	10.20
SG065BRO	6.500	8.500	7.242	7.987	23,100	12,610	41,040	17,870	75,775	41,535	10.80
SG070BRO	7.000	9.000	7.742	8.487	24,630	13,050	43,780	18,650	85,205	45,330	11.60
SG075BRO	7.500	9.500	8.242	8.987	26,170	13,490	46,510	19,420	95,185	49,235	12.20
SG080BRO	8.000	10.000	8.742	9.485	27,720	13,910	49,250	20,180	105,705	53,250	13.00
SG090BRO	9.000	11.000	9.742	10.485	30,810	14,740	54,720	21,640	128,395	61,600	14.40
SG100BRO	10.000	12.000	10.742	11.483	33,880	15,530	60,190	23,060	153,275	70,365	15.80
SG110BRO	11.000	13.000	11.742	12.481	36,960	16,290	65,660	24,440	180,340	79,535	17.20
SG140BRO	14.000	16.000	14.742	15.478	46,190	18,420	82,080	28,360	274,675	109,375	21.60
SG160BRO	16.000	18.000	16.742	17.474	52,350	19,720	93,020	30,830	348,505	131,090	24.60
SG180BRO	18.000	20.000	18.742	19.472	58,530	20,960	104,000	33,200	431,095	154,150	27.40
SG200BRO	20.000	22.000	20.742	21.468	64,690	22,110	114,900	35,490	522,435	178,475	31.60
SG250BRO	25.000	27.000	25.742	26.461	80,080	24,760	142,300	40,920	789,100	244,180	39.00
SG300BRO	30.000	32.000	30.742	31.451	95,480	27,110	169,600	46,020	1,110,480	315,755	46.60
SG350BRO	35.000	37.000	35.742	36.440	110,890	29,210	197,000	50,840	1,486,580	391,770	54.20

Brass; one piece pocket separator
standard 1/2" balls

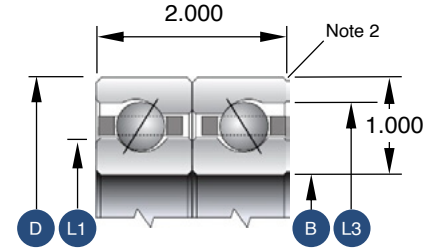

1. Load capacities are not additive
2. The maximum shaft or housing fillet radius that the bearing corners will clear for this series is 0.080"
3. Race Width Tolerance: +0.000 -0.010"

Inch Duplex Type F

Face-to-Face Paired Angular Contact Bearings



Two Type A bearings are often used as a duplex pair. This design is excellent for moment loading and reversing axial loading.

LOAD CONDITION				
RADIAL	AXIAL	MOMENT	REVERSING AXIAL	COMBINED RADIAL-THRUST
Very Good	Very Good	Very Good	Very Good	Good

SAA SERIES 3/16" X 3/16"

SILVERTHIN PART NUMBER	DIMENSIONS IN INCHES				CAPACITIES IN POUNDS						APPROX WEIGHT POUNDS
	BORE DIAMETER "B"	OUTSIDE DIAMETER "D"	LAND DIAMETER "L1"	LAND DIAMETER "L2"	RADIAL		THRUST		MOMENT (LBS-in)		
					STATIC	DYNAMIC	STATIC	DYNAMIC	STATIC	DYNAMIC	
SAA10FGO	1.000	1.375	1.140	1.235	550	310	970	450	165	95	0.05
SAA15FGO	1.500	1.875	1.640	1.735	780	390	1,380	560	375	185	0.08
SAA17FGO	1.750	2.125	1.890	1.985	860	400	1,520	600	490	235	0.09

Nylon; circular pocket separator standard 3/32" balls

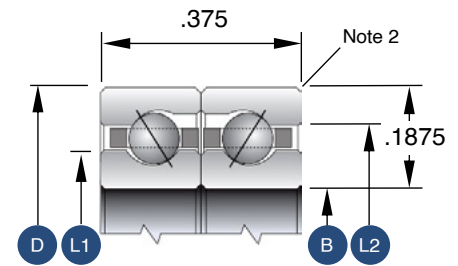

1. Load capacities are not additive
2. The maximum shaft or housing fillet radius that the bearing corners will clear for this series is 0.015"
3. Race Width Tolerance: +0.000 -0.010"

Inch Duplex Type F

Face-to-Face Paired Angular Contact Bearings



SA SERIES 1/4" X 1/4"

SILVERTHIN PART NUMBER	DIMENSIONS IN INCHES				CAPACITIES IN POUNDS						APPROX WEIGHT POUNDS
	BORE DIAMETER "B"	OUTSIDE DIAMETER "D"	LAND DIAMETER "L1"	LAND DIAMETER "L2"	RADIAL		THRUST		MOMENT (LBS-in)		
					STATIC	DYNAMIC	STATIC	DYNAMIC	STATIC	DYNAMIC	
SA020FRO	2.000	2.500	2.186	2.314	1,280	650	2,280	960	825	425	0.20
SA025FRO	2.500	3.000	2.686	2.814	1,560	740	2,780	1,100	1,290	615	0.26
SA030FRO	3.000	3.500	3.186	3.314	1,850	820	3,290	1,230	1,850	825	0.30
SA035FRO	3.500	4.000	3.686	3.814	2,120	890	3,790	1,350	2,515	1,060	0.36
SA040FRO	4.000	4.500	4.186	4.314	2,420	960	4,300	1,470	3,280	1,315	0.38
SA042FRO	4.250	4.750	4.436	4.564	2,560	990	4,550	1,530	3,705	1,445	0.40
SA045FRO	4.500	5.000	4.686	4.814	2,690	1,030	4,810	1,580	4,150	1,585	0.44
SA047FRO	4.750	5.250	4.936	5.064	2,840	1,060	5,060	1,640	4,620	1,730	0.46
SA050FRO	5.000	5.500	5.186	5.314	2,990	1,090	5,310	1,690	5,115	1,880	0.48
SA055FRO	5.500	6.000	5.686	5.814	3,280	1,160	5,820	1,800	6,185	2,195	0.50
SA060FRO	6.000	6.500	6.186	6.314	3,550	1,210	6,320	1,900	7,355	2,525	0.56
SA065FRO	6.500	7.000	6.686	6.814	3,850	1,280	6,830	2,000	8,630	2,870	0.60
SA070FRO	7.000	7.500	7.186	7.314	4,120	1,340	7,340	2,100	10,000	3,240	0.62
SA075FRO	7.500	8.000	7.686	7.814	4,420	1,380	7,840	2,190	11,475	3,620	0.68
SA080FRO	8.000	8.500	8.186	8.314	4,690	1,440	8,350	2,280	13,050	4,020	0.76
SA090FRO	9.000	9.500	9.186	9.314	5,260	1,550	9,360	2,470	16,505	4,860	0.88
SA100FRO	10.000	10.500	10.186	10.314	5,830	1,640	10,370	2,640	20,360	5,755	1.00
SA110FRO	11.000	11.500	11.186	11.314	6,400	1,730	11,380	2,810	24,625	6,705	1.04
SA120FRO	12.000	12.500	12.186	12.314	6,970	1,830	12,390	2,970	29,290	7,700	1.12

Brass; one piece pocket separator
standard 1/8" balls

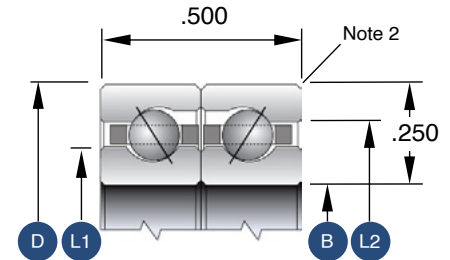

1. Load capacities are not additive
2. The maximum shaft or housing fillet radius that the bearing corners will clear for this series is 0.025"
3. Race Width Tolerance: +0.000 -0.010"

Inch Duplex Type F

Face-to-Face Paired Angular Contact Bearings



SB SERIES 5/16" X 5/16"

SILVERTHIN PART NUMBER	DIMENSIONS IN INCHES				CAPACITIES IN POUNDS						APPROX WEIGHT POUNDS
	BORE DIAMETER "B"	OUTSIDE DIAMETER "D"	LAND DIAMETER "L1"	LAND DIAMETER "L2"	RADIAL		THRUST		MOMENT (LBS-in)		
					STATIC	DYNAMIC	STATIC	DYNAMIC	STATIC	DYNAMIC	
SB020FRO	2.000	2.625	2.231	2.393	1,770	970	3,150	1,380	1,095	600	0.32
SB025FRO	2.500	3.125	2.731	2.893	2,170	1,090	3,860	1,590	1,730	885	0.38
SB030FRO	3.000	3.625	3.231	3.393	2,510	1,190	4,470	1,750	2,495	1,195	0.48
SB035FRO	3.500	4.125	3.731	3.893	2,900	1,300	5,180	1,930	3,400	1,530	0.58
SB040FRO	4.000	4.625	4.231	4.393	3,310	1,400	5,890	2,100	4,440	1,895	0.60
SB042FRO	4.250	4.875	4.481	4.643	3,490	1,440	6,200	2,170	5,010	2,090	0.62
SB045FRO	4.500	5.125	4.731	4.893	3,650	1,480	6,500	2,240	5,615	2,290	0.66
SB047FRO	4.750	5.375	4.981	5.143	3,880	1,540	6,910	2,340	6,250	2,495	0.68
SB050FRO	5.000	5.625	5.231	5.393	4,060	1,580	7,210	2,410	6,925	2,710	0.76
SB055FRO	5.500	6.125	5.731	5.893	4,450	1,680	7,920	2,560	8,370	3,150	0.82
SB060FRO	6.000	6.625	6.231	6.393	4,850	1,770	8,630	2,710	9,950	3,620	0.88
SB065FRO	6.500	7.125	6.731	6.893	5,200	1,830	9,240	2,840	11,665	4,115	0.94
SB070FRO	7.000	7.625	7.231	7.393	5,600	1,920	9,960	2,980	13,520	4,630	1.00
SB075FRO	7.500	8.125	7.731	7.893	6,010	2,000	10,670	3,120	15,510	5,170	1.06
SB080FRO	8.000	8.625	8.231	8.393	6,400	2,080	11,380	3,260	17,635	5,735	1.14
SB090FRO	9.000	9.625	9.231	9.393	7,150	2,220	12,700	3,510	22,290	6,925	1.32
SB100FRO	10.000	10.625	10.231	10.393	7,940	2,370	14,120	3,760	27,495	8,205	1.46
SB110FRO	11.000	11.625	11.231	11.393	8,690	2,500	15,440	4,000	33,245	9,560	1.50
SB120FRO	12.000	12.625	12.231	12.393	9,490	2,640	16,860	4,240	39,540	10,995	1.66
SB140FRO	14.000	14.625	14.231	14.393	10,980	2,860	19,500	4,670	53,775	14,070	2.10
SB160FRO	16.000	16.625	16.231	16.393	12,520	3,090	22,250	5,100	70,200	17,400	2.40
SB180FRO	18.000	18.625	18.231	18.393	14,070	3,310	24,990	5,510	88,825	20,950	2.70
SB200FRO	20.000	20.625	20.231	20.393	15,610	3,510	27,730	5,900	109,655	24,680	3.00

Brass; one piece pocket separator
standard 5/32" balls

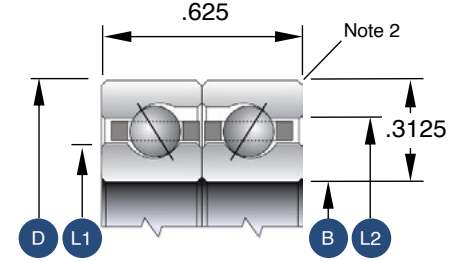

1. Load capacities are not additive
2. The maximum shaft or housing fillet radius that the bearing corners will clear for this series is 0.040"
3. Race Width Tolerance: +0.000 -0.010"

Inch Duplex Type F

Face-to-Face Paired Angular Contact Bearings



SC SERIES 3/8" X 3/8"

SILVERTHIN PART NUMBER	DIMENSIONS IN INCHES				CAPACITIES IN POUNDS						APPROX WEIGHT POUNDS
	BORE DIAMETER "B"	OUTSIDE DIAMETER "D"	LAND DIAMETER "L1"	LAND DIAMETER "L2"	RADIAL		THRUST		MOMENT (LBS-in)		
					STATIC	DYNAMIC	STATIC	DYNAMIC	STATIC	DYNAMIC	
SC040FRO	4.000	4.750	4.277	4.473	4,140	1,870	7,360	2,770	5,495	2,470	0.90
SC042FRO	4.250	5.000	4.527	4.723	4,400	1,940	7,820	2,880	6,210	2,735	0.94
SC045FRO	4.500	5.250	4.777	4.973	4,640	2,000	8,270	2,990	6,965	3,005	0.96
SC047FRO	4.750	5.500	5.027	5.223	4,900	2,070	8,720	3,100	7,765	3,290	1.00
SC050FRO	5.000	5.750	5.277	5.473	5,160	2,130	9,170	3,200	8,610	3,575	1.16
SC055FRO	5.500	6.250	5.777	5.973	5,590	2,230	9,920	3,370	10,420	4,175	1.18
SC060FRO	6.000	6.750	6.277	6.473	6,090	2,350	10,820	3,580	12,405	4,805	1.26
SC065FRO	6.500	7.250	6.777	6.973	6,590	2,470	11,720	3,770	14,560	5,465	1.36
SC070FRO	7.000	7.750	7.277	7.473	7,020	2,550	12,470	3,930	16,885	6,155	1.46
SC075FRO	7.500	8.250	7.777	7.973	7,520	2,660	13,380	4,120	19,380	6,870	1.56
SC080FRO	8.000	8.750	8.277	8.473	8,040	2,770	14,280	4,300	22,050	7,620	1.68
SC090FRO	9.000	9.750	9.277	9.473	8,970	2,950	15,930	4,630	27,895	9,195	1.88
SC100FRO	10.000	10.750	10.277	10.473	9,970	3,150	17,730	4,970	34,425	10,875	2.12
SC110FRO	11.000	11.750	11.277	11.473	10,920	3,320	19,390	5,280	41,635	12,660	2.32
SC120FRO	12.000	12.750	12.277	12.473	11,840	3,480	21,040	5,570	49,530	14,545	2.50
SC140FRO	14.000	14.750	14.277	14.473	13,790	3,810	24,500	6,170	67,370	18,595	3.04
SC160FRO	16.000	16.750	16.277	16.473	15,730	4,110	27,950	6,730	87,935	23,000	3.46
SC180FRO	18.000	18.750	18.277	18.473	17,680	4,390	31,410	7,280	111,230	27,730	3.88
SC200FRO	20.000	20.750	20.277	20.473	19,540	4,650	34,720	7,780	137,255	32,745	4.32
SC250FRO	25.000	25.750	25.277	25.473	24,210	5,250	43,280	9,010	214,240	46,360	5.38
SC300FRO	30.000	30.750	30.277	30.473	29,180	5,780	51,850	10,160	308,260	61,115	6.42

Brass; one piece pocket separator
standard 3/16" ball

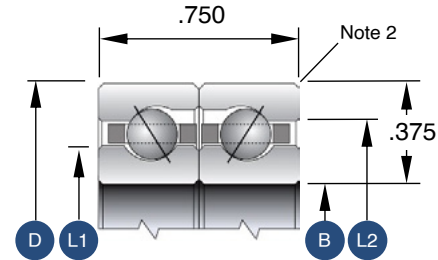

1. Load capacities are not additive
2. The maximum shaft or housing fillet radius that the bearing corners will clear for this series is 0.040"
3. Race Width Tolerance: +0.000 -0.010"

SD SERIES 1/2" X 1/2"

SILVERTHIN PART NUMBER	DIMENSIONS IN INCHES				CAPACITIES IN POUNDS						APPROX WEIGHT POUNDS
	BORE DIAMETER "B"	OUTSIDE DIAMETER "D"	LAND DIAMETER "L1"	LAND DIAMETER "L2"	RADIAL		THRUST		MOMENT (LBS-in)		
					STATIC	DYNAMIC	STATIC	DYNAMIC	STATIC	DYNAMIC	
SD040FRO	4.000	5.000	4.370	4.630	5,760	2,950	10,260	4,260	7,455	3,795	1.56
SD042FRO	4.250	5.250	4.620	4.880	6,090	3,040	10,830	4,420	8,415	4,200	1.66
SD045FRO	4.500	5.500	4.870	5.130	6,410	3,130	11,400	4,570	9,425	4,610	1.76
SD047FRO	4.750	5.750	5.120	5.380	6,740	3,220	11,970	4,720	10,495	5,035	1.88
SD050FRO	5.000	6.000	5.370	5.630	7,050	3,310	12,540	4,870	11,620	5,475	2.00
SD055FRO	5.500	6.500	5.870	6.130	7,700	3,480	13,680	5,160	14,045	6,380	2.12
SD060FRO	6.000	7.000	6.370	6.630	8,330	3,640	14,820	5,440	16,700	7,335	2.32
SD065FRO	6.500	7.500	6.870	7.130	8,980	3,810	15,960	5,720	19,580	8,335	2.44
SD070FRO	7.000	8.000	7.370	7.630	9,620	3,960	17,100	5,990	22,690	9,375	2.62
SD075FRO	7.500	8.500	7.870	8.130	10,270	4,110	18,240	6,250	26,025	10,460	2.82
SD080FRO	8.000	9.000	8.370	8.630	10,900	4,260	19,380	6,510	29,590	11,585	3.06
SD090FRO	9.000	10.000	9.370	9.630	12,180	4,550	21,660	7,010	37,400	13,965	3.44
SD100FRO	10.000	11.000	10.370	10.630	13,470	4,820	23,940	7,500	46,125	16,505	3.76
SD110FRO	11.000	12.000	11.370	11.630	14,750	5,090	26,220	7,960	55,765	19,205	4.12
SD120FRO	12.000	13.000	12.370	12.630	16,030	5,340	28,500	8,420	66,315	22,050	4.50
SD140FRO	14.000	15.000	14.370	14.630	18,600	5,810	33,060	9,290	90,150	28,170	5.46
SD160FRO	16.000	17.000	16.370	16.630	21,170	6,260	37,620	10,130	117,630	34,815	6.20
SD180FRO	18.000	19.000	18.370	18.630	23,740	6,680	42,180	10,930	148,760	41,950	6.96
SD200FRO	20.000	21.000	20.370	20.630	26,300	7,070	46,740	11,710	183,540	49,520	7.70
SD250FRO	25.000	26.000	25.370	25.630	27,590	7,260	49,020	12,085	286,445	70,060	9.58
SD300FRO	30.000	31.000	30.370	30.630	39,140	8,760	69,540	15,260	412,150	92,340	11.46

Brass; one piece pocket separator
standard 1/4" balls

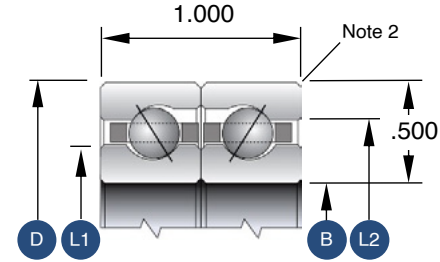

1. Load capacities are not additive
2. The maximum shaft or housing fillet radius that the bearing corners will clear for this series is 0.060"
3. Race Width Tolerance: +0.000 -0.010"



Inch Duplex Type F

Face-to-Face Paired Angular Contact Bearings



SF SERIES 3/4" X 3/4"

SILVERTHIN PART NUMBER	DIMENSIONS IN INCHES				CAPACITIES IN POUNDS						APPROX WEIGHT POUNDS
	BORE DIAMETER "B"	OUTSIDE DIAMETER "D"	LAND DIAMETER "L1"	LAND DIAMETER "L2"	RADIAL		THRUST		MOMENT (LBS-in)		
					STATIC	DYNAMIC	STATIC	DYNAMIC	STATIC	DYNAMIC	
SF040FRO	4.000	5.500	4.555	4.945	10,310	6,060	18,340	8,420	17,880	11,660	3.80
SF042FRO	4.250	5.750	4.805	5.195	10,720	6,180	19,050	8,630	20,215	12,955	4.00
SF045FRO	4.500	6.000	5.060	5.445	11,520	6,440	20,460	9,050	22,680	14,285	4.20
SF047FRO	4.750	6.250	5.305	5.695	11,910	6,550	21,160	9,260	25,285	15,645	4.40
SF050FRO	5.000	6.500	5.555	5.945	12,300	6,660	21,870	9,460	28,025	17,040	4.60
SF055FRO	5.500	7.000	6.055	6.445	13,500	7,020	23,980	10,060	33,915	19,920	5.00
SF060FRO	6.000	7.500	6.555	6.945	14,690	7,360	26,100	10,650	40,355	22,920	5.40
SF065FRO	6.500	8.000	7.055	7.445	15,870	7,690	28,220	11,220	47,345	26,050	5.80
SF070FRO	7.000	8.500	7.555	7.945	17,070	8,010	30,330	11,770	54,875	29,300	6.40
SF075FRO	7.500	9.000	8.055	8.445	17,870	8,200	31,740	12,130	62,960	32,670	6.80
SF080FRO	8.000	9.500	8.555	8.945	19,060	8,510	33,860	12,670	71,585	36,155	7.00
SF090FRO	9.000	10.500	9.555	9.945	21,430	9,110	38,090	13,700	90,485	43,480	7.80
SF100FRO	10.000	11.500	10.555	10.945	23,430	9,570	41,620	14,530	111,570	51,260	8.60
SF110FRO	11.000	12.500	11.555	11.945	25,800	10,110	45,850	15,500	134,845	59,480	9.60
SF120FRO	12.000	13.500	12.555	12.945	27,780	10,530	49,380	16,290	160,310	68,130	10.40
SF140FRO	14.000	15.500	14.555	14.945	32,150	11,440	57,140	17,950	217,805	86,660	12.00
SF160FRO	16.000	17.500	16.555	16.945	36,530	12,290	64,890	19,540	284,055	106,755	14.20
SF180FRO	18.000	19.500	18.555	18.945	41,290	13,170	73,360	21,210	359,065	128,305	15.80
SF200FRO	20.000	21.500	20.555	20.945	45,660	13,910	81,120	22,680	442,825	151,210	17.80
SF250FRO	25.000	26.500	25.555	25.945	56,380	15,570	100,200	26,100	690,530	213,725	21.80
SF300FRO	30.000	31.500	30.555	30.945	67,500	17,110	119,900	29,430	992,955	282,455	26.00
SF350FRO	35.000	36.500	35.555	35.945	78,610	18,490	139,700	32,580	1,350,100	355,795	30.20

Brass; one piece pocket separator standard 3/8" balls

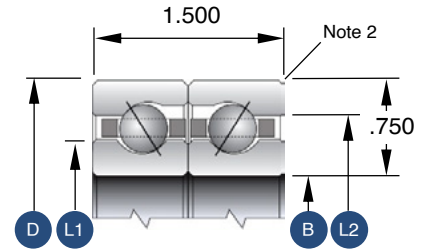

1. Load capacities are not additive
2. The maximum shaft or housing fillet radius that the bearing corners will clear for this series is 0.080"
3. Race Width Tolerance: +0.000 -0.010"



Inch Duplex Type F

Face-to-Face Paired Angular Contact Bearings



SG SERIES 1" X 1"

SILVERTHIN PART NUMBER	DIMENSIONS IN INCHES				CAPACITIES IN POUNDS						APPROX WEIGHT POUNDS
	BORE DIAMETER "B"	OUTSIDE DIAMETER "D"	LAND DIAMETER "L1"	LAND DIAMETER "L2"	RADIAL		THRUST		MOMENT (LBS-in)		
					STATIC	DYNAMIC	STATIC	DYNAMIC	STATIC	DYNAMIC	
SG040FRO	4.000	6.000	4.742	5.258	15,400	10,200	27,360	13,630	17,880	10,705	7.20
SG042FRO	4.250	6.250	4.992	5.508	16,160	10,460	28,730	14,090	20,210	12,275	7.60
SG045FRO	4.500	6.500	5.242	5.758	16,940	10,660	30,100	14,530	22,680	13,865	8.00
SG050FRO	5.000	7.000	5.742	6.258	18,470	11,200	32,830	15,400	28,025	17,100	8.60
SG055FRO	5.500	7.500	6.242	6.758	20,020	11,680	35,570	16,240	33,915	20,420	9.40
SG060FRO	6.000	8.000	6.742	7.258	21,560	12,150	38,300	17,060	40,355	23,815	10.20
SG065FRO	6.500	8.500	7.242	7.758	23,100	12,610	41,040	17,870	47,345	27,290	10.80
SG070FRO	7.000	9.000	7.742	8.258	24,630	13,050	43,780	18,650	54,875	30,845	11.60
SG075FRO	7.500	9.500	8.242	8.758	26,170	13,490	46,510	19,420	62,960	34,480	12.20
SG080FRO	8.000	10.000	8.742	9.258	27,720	13,910	49,250	20,180	71,585	38,190	13.00
SG090FRO	9.000	11.000	9.742	10.258	30,810	14,740	54,720	21,640	90,485	45,855	14.40
SG100FRO	10.000	12.000	10.742	11.258	33,880	15,530	60,190	23,060	111,570	53,840	15.80
SG110FRO	11.000	13.000	11.742	12.258	36,960	16,290	65,660	24,440	134,845	62,140	17.20
SG120FRO	12.000	14.000	12.742	13.258	40,040	17,030	71,140	25,780	160,310	70,755	18.60
SG140FRO	14.000	16.000	14.742	15.258	46,190	18,420	82,080	28,360	217,805	88,945	21.60
SG160FRO	16.000	18.000	16.742	17.258	52,350	19,720	93,020	30,830	284,055	108,400	24.60
SG180FRO	18.000	20.000	18.742	19.258	58,530	20,960	104,000	33,200	359,065	129,130	27.40
SG200FRO	20.000	22.000	20.742	21.258	64,690	22,110	114,900	35,490	442,825	151,130	31.60
SG250FRO	25.000	27.000	25.742	26.258	80,080	24,760	142,300	40,920	690,530	211,685	39.00
SG300FRO	30.000	32.000	30.742	31.258	95,480	27,110	169,600	46,020	992,955	280,175	46.60
SG350FRO	35.000	37.000	35.742	36.258	110,890	29,210	197,000	50,840	1,350,100	356,605	54.20

Brass; one piece pocket separator
standard 1/2" balls

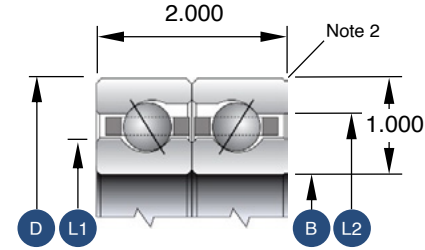

1. Load capacities are not additive
2. The maximum shaft or housing fillet radius that the bearing corners will clear for this series is 0.080"
3. Race Width Tolerance: +0.000 -0.010"

Inch Duplex Type T

Tandem Paired Angular Contact Bearings



Two Type A bearings are often used as a duplex pair. This design is excellent for axial loading.

LOAD CONDITION				
RADIAL	AXIAL	MOMENT	REVERSING AXIAL	COMBINED RADIAL-THRUST
Very Good	Excellent	Do Not Use	Do Not Use	Do Not Use

SAA SERIES 3/16" X 3/16"

SILVERTHIN PART NUMBER	DIMENSIONS IN INCHES					CAPACITIES IN POUNDS				APPROX WEIGHT POUNDS
	BORE DIAMETER "B"	OUTSIDE DIAMETER "D"	LAND DIAMETER "L1"	LAND DIAMETER "L2"	C'BORE DIAMETER "L3"	RADIAL		THRUST		
						STATIC	DYNAMIC	STATIC	DYNAMIC	
SAA10TGO	1.000	1.375	1.140	1.235	1.274	555	315	1,575	730	0.05
SAA15TGO	1.500	1.875	1.640	1.735	1.774	780	390	2,245	910	0.08
SAA17TGO	1.750	2.125	1.890	1.985	2.024	860	405	2,470	975	0.09

Nylon; circular pocket separator standard 3/32" balls

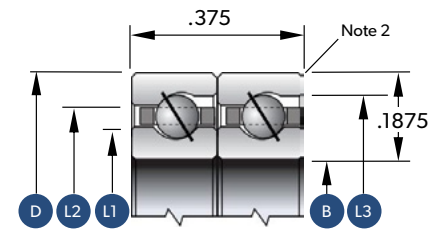

1. Load capacities are not additive
2. The maximum shaft or housing fillet radius that the bearing corners will clear for this series is 0.015"
3. Race Width Tolerance: +0.000 -0.010"

Inch Duplex Type T

Tandem Paired Angular Contact Bearings



SA SERIES 1/4" X 1/4"

SILVERTHIN PART NUMBER	DIMENSIONS IN INCHES					CAPACITIES IN POUNDS				APPROX WEIGHT POUNDS
	BORE DIAMETER "B"	OUTSIDE DIAMETER "D"	LAND DIAMETER "L1"	LAND DIAMETER "L2"	C'BORE DIAMETER "L3"	RADIAL		THRUST		
						STATIC	DYNAMIC	STATIC	DYNAMIC	
SA020TRO	2.000	2.500	2.186	2.314	2.369	1,285	660	3,705	1,560	0.20
SA025TRO	2.500	3.000	2.686	2.814	2.869	1,560	750	4,520	1,790	0.26
SA030TRO	3.000	3.500	3.186	3.314	3.367	1,855	820	5,345	2,000	0.30
SA035TRO	3.500	4.000	3.686	3.814	3.867	2,130	895	6,160	2,195	0.36
SA040TRO	4.000	4.500	4.186	4.314	4.367	2,420	965	6,990	2,390	0.38
SA042TRO	4.250	4.750	4.436	4.564	4.615	2,570	1,000	7,395	2,485	0.40
SA045TRO	4.500	5.000	4.686	4.814	4.865	2,700	1,030	7,815	2,570	0.44
SA047TRO	4.750	5.250	4.936	5.064	5.115	2,845	1,065	8,225	2,665	0.46
SA050TRO	5.000	5.500	5.186	5.314	5.365	2,990	1,095	8,630	2,745	0.48
SA055TRO	5.500	6.000	5.686	5.814	5.863	3,285	1,160	9,460	2,925	0.50
SA060TRO	6.000	6.500	6.186	6.314	6.363	3,560	1,220	10,270	3,090	0.56
SA065TRO	6.500	7.000	6.686	6.814	6.861	3,850	1,285	11,100	3,250	0.60
SA070TRO	7.000	7.500	7.186	7.314	7.361	4,130	1,340	11,930	3,415	0.62
SA075TRO	7.500	8.000	7.686	7.814	7.861	4,420	1,390	12,740	3,560	0.68
SA080TRO	8.000	8.500	8.186	8.314	8.359	4,695	1,445	13,570	3,705	0.76
SA090TRO	9.000	9.500	9.186	9.314	9.357	5,265	1,550	15,210	4,015	0.88
SA100TRO	10.000	10.500	10.186	10.314	10.355	5,835	1,650	16,850	4,290	1.00
SA110TRO	11.000	11.500	11.186	11.314	11.353	6,405	1,740	18,495	4,565	1.04
SA120TRO	12.000	12.500	12.186	12.314	12.349	6,970	1,835	20,135	4,825	1.12

Brass; circular pocket separator
standard 1/8" balls

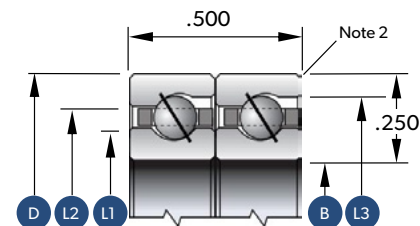

1. Load capacities are not additive
2. The maximum shaft or housing fillet radius that the bearing corners will clear for this series is 0.025"
3. Race Width Tolerance: +0.000 -0.010"

Inch Duplex Type T

Tandem Paired Angular Contact Bearings



SB SERIES 5/16" X 5/16"

SILVERTHIN PART NUMBER	DIMENSIONS IN INCHES					CAPACITIES IN POUNDS				APPROX WEIGHT POUNDS
	BORE DIAMETER "B"	OUTSIDE DIAMETER "D"	LAND DIAMETER "L1"	LAND DIAMETER "L2"	C'BORE DIAMETER "L3"	RADIAL		THRUST		
						STATIC	DYNAMIC	STATIC	DYNAMIC	
SB020TRO	2.000	2.625	2.231	2.393	2.464	1,770	975	5,120	2,245	0.32
SB025TRO	2.500	3.125	2.731	2.893	2.964	2,180	1,095	6,275	2,585	0.38
SB030TRO	3.000	3.625	3.231	3.393	3.462	2,520	1,195	7,265	2,845	0.48
SB035TRO	3.500	4.125	3.731	3.893	3.962	2,910	1,300	8,420	3,135	0.58
SB040TRO	4.000	4.625	4.231	4.393	4.460	3,315	1,405	9,570	3,415	0.60
SB042TRO	4.250	4.875	4.481	4.643	4.710	3,495	1,445	10,075	3,525	0.62
SB045TRO	4.500	5.125	4.731	4.893	4.960	3,655	1,485	10,565	3,640	0.66
SB047TRO	4.750	5.375	4.981	5.143	5.210	3,885	1,545	11,230	3,805	0.68
SB050TRO	5.000	5.625	5.231	5.393	5.460	4,065	1,585	11,715	3,915	0.76
SB055TRO	5.500	6.125	5.731	5.893	5.958	4,455	1,680	12,870	4,160	0.82
SB060TRO	6.000	6.625	6.231	6.393	6.458	4,860	1,770	14,025	4,405	0.88
SB065TRO	6.500	7.125	6.731	6.893	6.958	5,200	1,835	15,015	4,615	0.94
SB070TRO	7.000	7.625	7.231	7.393	7.456	5,605	1,925	16,185	4,845	1.00
SB075TRO	7.500	8.125	7.731	7.893	7.955	6,015	2,005	17,340	5,070	1.06
SB080TRO	8.000	8.625	8.231	8.393	8.453	6,405	2,090	18,495	5,300	1.14
SB090TRO	9.000	9.625	9.231	9.393	9.451	7,150	2,225	20,640	5,705	1.32
SB100TRO	10.000	10.625	10.231	10.393	10.449	7,945	2,375	22,945	6,110	1.46
SB110TRO	11.000	11.625	11.231	11.393	11.447	8,695	2,505	25,090	6,500	1.50
SB120TRO	12.000	12.625	12.231	12.393	12.445	9,490	2,640	27,400	6,890	1.66
SB140TRO	14.000	14.625	14.231	14.393	14.439	10,985	2,870	31,690	7,590	2.10
SB160TRO	16.000	16.625	16.231	16.393	16.433	12,530	3,095	36,155	8,290	2.40
SB180TRO	18.000	18.625	18.231	18.393	18.425	14,075	3,315	40,610	8,955	2.70
SB200TRO	20.000	20.625	20.231	20.393	20.416	15,615	3,510	45,060	9,590	3.00

Brass; circular pocket separator
standard 5/32" balls

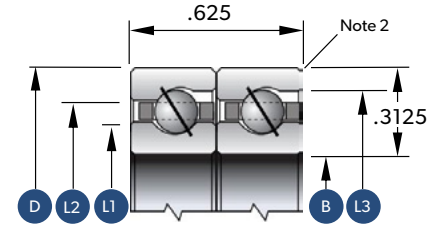

1. Load capacities are not additive
2. The maximum shaft or housing fillet radius that the bearing corners will clear for this series is 0.040"
3. Race Width Tolerance: +0.000 -0.010"

Inch Duplex Type T

Tandem Paired Angular Contact Bearings



SC SERIES 3/8" X 3/8"

SILVERTHIN PART NUMBER	DIMENSIONS IN INCHES					CAPACITIES IN POUNDS				APPROX WEIGHT POUNDS
	BORE DIAMETER "B"	OUTSIDE DIAMETER "D"	LAND DIAMETER "L1"	LAND DIAMETER "L2"	C'BORE DIAMETER "L3"	RADIAL		THRUST		
						STATIC	DYNAMIC	STATIC	DYNAMIC	
SC040TRO	4.000	4.750	4.277	4.473	4.554	4,145	1,875	11,960	4,500	0.90
SC042TRO	4.250	5.000	4.527	4.723	4.804	4,405	1,940	12,710	4,680	0.94
SC045TRO	4.500	5.250	4.777	4.973	5.052	4,650	2,005	13,440	4,860	0.96
SC047TRO	4.750	5.500	5.027	5.223	5.302	4,910	2,070	14,170	5,040	1.00
SC050TRO	5.000	5.750	5.277	5.473	5.552	5,170	2,135	14,900	5,200	1.16
SC055TRO	5.500	6.250	5.777	5.973	6.052	5,590	2,235	16,120	5,475	1.18
SC060TRO	6.000	6.750	6.277	6.473	6.550	6,095	2,355	17,585	5,820	1.26
SC065TRO	6.500	7.250	6.777	6.973	7.050	6,600	2,470	19,045	6,125	1.36
SC070TRO	7.000	7.750	7.277	7.473	7.550	7,020	2,560	20,265	6,385	1.46
SC075TRO	7.500	8.250	7.777	7.973	8.048	7,525	2,665	21,745	6,695	1.56
SC080TRO	8.000	8.750	8.277	8.473	8.548	8,045	2,780	23,205	6,990	1.68
SC090TRO	9.000	9.750	9.277	9.473	9.546	8,970	2,960	25,885	7,525	1.88
SC100TRO	10.000	10.750	10.277	10.473	10.544	9,980	3,155	28,810	8,075	2.12
SC110TRO	11.000	11.750	11.277	11.473	11.542	10,920	3,325	31,510	8,580	2.32
SC120TRO	12.000	12.750	12.277	12.473	12.540	11,845	3,485	34,190	9,050	2.50
SC140TRO	14.000	14.750	14.277	14.473	14.535	13,795	3,810	39,815	10,025	3.04
SC160TRO	16.000	16.750	16.277	16.473	16.529	15,730	4,120	45,420	10,935	3.46
SC180TRO	18.000	18.750	18.277	18.473	18.523	17,680	4,395	51,040	11,830	3.88
SC200TRO	20.000	20.750	20.277	20.473	20.517	19,550	4,655	56,420	12,645	4.32
SC250TRO	25.000	25.750	25.277	25.473	25.500	24,215	5,255	70,330	14,640	5.38
SC300TRO	30.000	30.750	30.277	30.473	30.484	29,185	5,785	84,255	16,510	6.42

Brass; circular pocket separator
standard 3/16" ball

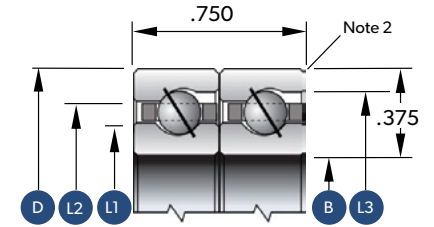

1. Load capacities are not additive
2. The maximum shaft or housing fillet radius that the bearing corners will clear for this series is 0.040"
3. Race Width Tolerance: +0.000 -0.010"

SD SERIES 1/2" X 1/2"

SILVERTHIN PART NUMBER	DIMENSIONS IN INCHES					CAPACITIES IN POUNDS				APPROX WEIGHT POUNDS
	BORE DIAMETER "B"	OUTSIDE DIAMETER "D"	LAND DIAMETER "L1"	LAND DIAMETER "L2"	C'BORE DIAMETER "L3"	RADIAL		THRUST		
						STATIC	DYNAMIC	STATIC	DYNAMIC	
SD040TRO	4.000	5.000	4.370	4.630	4.741	5,770	2,960	16,675	6,925	1.56
SD042TRO	4.250	5.250	4.620	4.880	4.991	6,095	3,045	17,600	7,185	1.66
SD045TRO	4.500	5.500	4.870	5.130	5.241	6,420	3,135	18,525	7,425	1.76
SD047TRO	4.750	5.750	5.120	5.380	5.490	6,745	3,225	19,450	7,670	1.88
SD050TRO	5.000	6.000	5.370	5.630	5.740	7,055	3,315	20,380	7,915	2.00
SD055TRO	5.500	6.500	5.870	6.130	6.238	7,705	3,485	22,230	8,385	2.12
SD060TRO	6.000	7.000	6.370	6.630	6.738	8,335	3,650	24,085	8,840	2.32
SD065TRO	6.500	7.500	6.870	7.130	7.236	8,985	3,810	25,935	9,295	2.44
SD070TRO	7.000	8.000	7.370	7.630	7.736	9,620	3,965	27,790	9,735	2.62
SD075TRO	7.500	8.500	7.870	8.130	8.236	10,270	4,120	29,640	10,155	2.82
SD080TRO	8.000	9.000	8.370	8.630	8.734	10,905	4,265	31,495	10,580	3.06
SD090TRO	9.000	10.000	9.370	9.630	9.732	12,190	4,560	35,200	11,390	3.44
SD100TRO	10.000	11.000	10.370	10.630	10.732	13,470	4,825	38,905	12,190	3.76
SD110TRO	11.000	12.000	11.370	11.630	11.730	14,755	5,095	42,610	12,935	4.12
SD120TRO	12.000	13.000	12.370	12.630	12.728	16,040	5,345	46,315	13,685	4.50
SD140TRO	14.000	15.000	14.370	14.630	14.724	18,605	5,820	53,725	15,095	5.46
SD160TRO	16.000	17.000	16.370	16.630	16.718	21,175	6,265	61,135	16,460	6.20
SD180TRO	18.000	19.000	18.370	18.630	18.712	23,740	6,685	68,545	17,760	6.96
SD200TRO	20.000	21.000	20.370	20.630	20.705	26,310	7,075	75,955	19,030	7.70
SD250TRO	25.000	26.000	25.370	25.630	25.688	32,730	7,980	94,480	22,005	9.58
SD300TRO	30.000	31.000	30.370	30.630	30.672	39,145	8,765	113,005	24,800	11.46

Brass; circular pocket separator
standard 1/4" balls

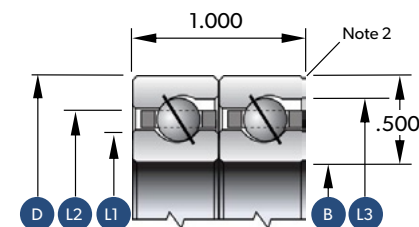

1. Load capacities are not additive
2. The maximum shaft or housing fillet radius that the bearing corners will clear for this series is 0.060"
3. Race Width Tolerance: +0.000 -0.010"

Inch Duplex Type T

Tandem Paired Angular Contact Bearings



SF SERIES 3/4" X 3/4"

SILVERTHIN PART NUMBER	DIMENSIONS IN INCHES					CAPACITIES IN POUNDS				APPROX WEIGHT POUNDS
	BORE DIAMETER "B"	OUTSIDE DIAMETER "D"	LAND DIAMETER "L1"	LAND DIAMETER "L2"	C'BORE DIAMETER "L3"	RADIAL		THRUST		
						STATIC	DYNAMIC	STATIC	DYNAMIC	
SF040TRO	4.000	5.500	4.555	4.945	5.115	10,320	6,070	29,805	13,685	3.80
SF042TRO	4.250	5.750	4.805	5.195	5.365	10,725	6,185	30,955	14,025	4.00
SF045TRO	4.500	6.000	5.060	5.445	5.615	11,520	6,445	33,250	14,705	4.20
SF047TRO	4.750	6.250	5.305	5.695	5.865	11,910	6,555	34,385	15,050	4.40
SF050TRO	5.000	6.500	5.555	5.945	6.115	12,300	6,665	35,540	15,375	4.60
SF055TRO	5.500	7.000	6.055	6.445	6.613	13,505	7,020	38,970	16,350	5.00
SF060TRO	6.000	7.500	6.555	6.945	7.113	14,690	7,360	42,415	17,305	5.40
SF065TRO	6.500	8.000	7.055	7.445	7.613	15,875	7,695	45,860	18,235	5.80
SF070TRO	7.000	8.500	7.555	7.945	8.113	17,080	8,010	49,285	19,125	6.40
SF075TRO	7.500	9.000	8.055	8.445	8.610	17,875	8,205	51,580	19,710	6.80
SF080TRO	8.000	9.500	8.555	8.945	9.110	19,060	8,515	55,025	20,590	7.00
SF090TRO	9.000	10.500	9.555	9.945	10.108	21,435	9,115	61,895	22,265	7.80
SF100TRO	10.000	11.500	10.555	10.945	11.106	23,435	9,570	67,635	23,610	8.60
SF110TRO	11.000	12.500	11.555	11.945	12.106	25,805	10,115	74,505	25,190	9.60
SF120TRO	12.000	13.500	12.555	12.945	13.104	27,790	10,540	80,245	26,470	10.40
SF140TRO	14.000	15.500	14.555	14.945	15.102	32,160	11,450	92,855	29,170	12.00
SF160TRO	16.000	17.500	16.555	16.945	17.098	36,530	12,295	105,445	31,755	14.20
SF180TRO	18.000	19.500	18.555	18.945	19.096	41,290	13,170	119,210	34,465	15.80
SF200TRO	20.000	21.500	20.555	20.945	21.092	45,665	13,910	131,820	36,855	17.80
SF250TRO	25.000	26.500	25.555	25.945	26.085	56,390	15,575	162,825	42,415	21.80
SF300TRO	30.000	31.500	30.555	30.945	31.075	67,505	17,120	194,840	47,825	26.00
SF350TRO	35.000	36.500	35.555	35.945	36.064	78,620	18,495	227,015	52,945	30.20

Brass; circular pocket separator
standard 3/8" balls

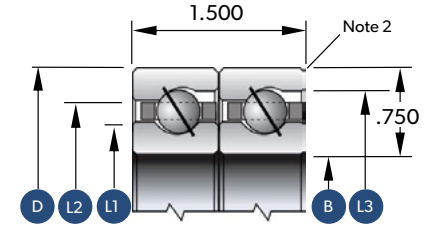

1. Load capacities are not additive
2. The maximum shaft or housing fillet radius that the bearing corners will clear for this series is 0.080"
3. Race Width Tolerance: +0.000 -0.010"

Inch Duplex Type T

Tandem Paired Angular Contact Bearings



SG SERIES 1" X 1"

SILVERTHIN PART NUMBER	DIMENSIONS IN INCHES					CAPACITIES IN POUNDS				APPROX WEIGHT POUNDS
	BORE DIAMETER "B"	OUTSIDE DIAMETER "D"	LAND DIAMETER "L1"	LAND DIAMETER "L2"	C'BORE DIAMETER "L3"	RADIAL		THRUST		
						STATIC	DYNAMIC	STATIC	DYNAMIC	
SG040TRO	4.000	6.000	4.742	5.258	5.491	15,405	10,205	44,460	22,150	7.20
SG042TRO	4.250	6.250	4.992	5.508	5.741	16,170	10,465	46,685	22,895	7.60
SG045TRO	4.500	6.500	5.242	5.758	5.989	16,950	10,660	48,915	23,610	8.00
SG047TRO	4.750	6.750	5.492	6.008	6.239	17,715	10,960	51,125	24,325	8.20
SG050TRO	5.000	7.000	5.742	6.258	6.489	18,475	11,205	53,350	25,025	8.60
SG055TRO	5.500	7.500	6.242	6.758	6.989	20,020	11,685	57,800	26,390	9.40
SG060TRO	6.000	8.000	6.742	7.258	7.489	21,565	12,155	62,240	27,725	10.20
SG065TRO	6.500	8.500	7.242	7.758	7.987	23,110	12,610	66,690	29,040	10.80
SG070TRO	7.000	9.000	7.742	8.258	8.487	24,635	13,055	71,145	30,305	11.60
SG075TRO	7.500	9.500	8.242	8.758	8.987	26,180	13,495	75,580	31,560	12.20
SG080TRO	8.000	10.000	8.742	9.258	9.485	27,725	13,920	80,030	32,795	13.00
SG090TRO	9.000	11.000	9.742	10.258	10.485	30,810	14,745	88,920	35,165	14.40
SG100TRO	10.000	12.000	10.742	11.258	11.483	33,880	15,535	97,810	37,475	15.80
SG110TRO	11.000	13.000	11.742	12.258	12.481	36,970	16,290	106,700	39,715	17.20
SG120TRO	12.000	14.000	12.742	13.258	13.481	40,040	17,030	115,605	41,895	18.60
SG140TRO	14.000	16.000	14.742	15.258	15.478	46,200	18,430	133,380	46,085	21.60
SG160TRO	16.000	18.000	16.742	17.258	17.474	52,360	19,730	151,160	50,100	24.60
SG180TRO	18.000	20.000	18.742	19.258	19.472	58,535	20,965	169,000	53,950	27.40
SG200TRO	20.000	22.000	20.742	21.258	21.468	64,690	22,115	186,715	57,670	31.60
SG250TRO	25.000	27.000	25.742	26.258	26.461	80,080	24,765	231,240	66,495	39.00
SG300TRO	30.000	32.000	30.742	31.258	31.451	95,485	27,115	275,600	74,785	46.60
SG350TRO	35.000	37.000	35.742	36.258	36.440	110,890	29,220	320,125	82,615	54.20

Brass; circular pocket separator
standard 1/2" balls

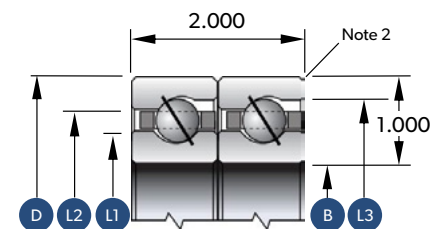

1. Load capacities are not additive
2. The maximum shaft or housing fillet radius that the bearing corners will clear for this series is 0.080"
3. Race Width Tolerance: +0.000 -0.010"

Metric Open Type A

Angular Contact Bearings



In applications with predominant axial or moment loads, angular contact ball bearings are often the appropriate selection. These bearings work well in all loading conditions (radial, axial, moment and combined loads). Type-A bearings are typically used with 2 bearings at a minimum for most applications.

Two Type A bearings are often used as a duplex pair. Different configurations for duplex bearings are shown in the Engineering section of this catalog. Please contact Silverthin™ for application of these bearings.

LOAD CONDITION				
RADIAL	AXIAL	MOMENT	REVERSING AXIAL	COMBINED RADIAL-THRUST
Good	Excellent	Excellent (Use In Pairs)	Excellent (Use In Pairs)	Good

SM08 SERIES 8MM X 8MM

SILVERTHIN PART NUMBER	DIMENSIONS IN MILLIMETERS					CAPACITIES IN NEWTONS				APPROX WEIGHT KG
	BORE DIAMETER "B"	OUTSIDE DIAMETER "D"	LAND DIAMETER "L1"	LAND DIAMETER "L2"	LAND DIAMETER "L3"	RADIAL		THRUST		
						STATIC	DYNAMIC	STATIC	DYNAMIC	
SM02508ARO	25	41	30.9	35.1	37.2	3,645	2,670	10,520	5,495	0.06
SM05008ARO	50	66	55.9	60.1	62.2	6,425	3,605	18,570	8,030	0.08
SM06008ARO	60	76	65.9	70.1	72.2	7,715	4,005	22,285	9,075	0.09
SM07008ARO	70	86	75.9	80.1	82.2	8,785	4,315	25,375	9,895	0.10
SM08008ARO	80	96	85.9	90.1	92.2	9,875	4,605	28,465	10,695	0.12
SM09008ARO	90	106	95.9	100.1	102.2	11,140	4,960	32,180	11,585	0.13
SM10008ARO	100	116	105.9	110.1	112.2	12,210	5,225	35,275	12,320	0.14
SM11008ARO	110	126	115.9	120.1	122.2	13,300	5,495	38,385	13,035	0.15
SM12008ARO	120	136	125.9	130.1	132.2	14,365	5,760	41,480	13,720	0.16
SM13008ARO	130	146	135.9	140.1	142.2	15,655	6,070	45,190	14,525	0.17
SM14008ARO	140	156	145.9	150.1	152.2	16,725	6,315	48,285	15,190	0.18
SM15008ARO	150	166	155.9	160.1	162.2	17,790	6,540	51,375	15,835	0.20
SM16008ARO	160	176	165.9	170.1	172.2	19,080	6,830	55,090	16,590	0.20
SM17008ARO	170	186	175.9	180.1	182.2	20,150	7,050	58,180	17,190	0.21
SM18008ARO	180	196	185.9	190.1	192.2	21,240	7,270	61,270	17,815	0.22
SM19008ARO	190	206	195.9	200.1	202.2	22,505	7,540	64,985	18,525	0.23
SM20008ARO	200	216	205.9	210.1	212.2	23,575	7,760	68,100	19,105	0.23
SM25008ARO	250	266	255.9	260.1	262.2	29,155	8,805	84,180	21,995	0.28
SM30008ARO	300	316	305.9	310.1	312.2	34,940	9,785	100,905	24,820	0.33
SM32008ARO	320	336	325.9	330.1	332.2	37,320	10,185	107,710	25,930	0.36
SM34008ARO	340	356	345.9	350.1	352.2	39,455	10,520	113,890	26,910	0.38
SM36008ARO	360	376	365.9	370.1	372.2	41,810	10,875	120,695	27,980	0.40

Brass; one piece pocket separator
standard 5/32" balls

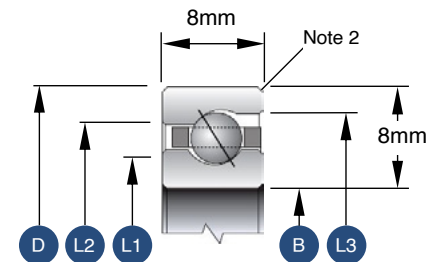

1. Load capacities are not additive
2. The maximum shaft or housing fillet radius that the bearing corners will clear for this series is 0.8mm
3. Race Width Tolerance: +0.000 -0.127mm



SM13 SERIES 13MM X 13MM

SILVERTHIN PART NUMBER	DIMENSIONS IN MILLIMETERS					CAPACITIES IN NEWTONS				APPROX WEIGHT KG
	BORE DIAMETER "B"	OUTSIDE DIAMETER "D"	LAND DIAMETER "L1"	LAND DIAMETER "L2"	LAND DIAMETER "L3"	RADIAL		THRUST		
						STATIC	DYNAMIC	STATIC	DYNAMIC	
SM08013ARO	80	106	89.7	96.3	99.6	15,925	8,965	45,950	20,105	0.26
SM09013ARO	90	116	99.7	106.3	109.6	17,570	9,450	50,705	21,485	0.29
SM10013ARO	100	126	109.7	116.3	119.6	19,215	9,940	55,465	22,795	0.32
SM11013ARO	110	136	119.7	126.3	129.6	20,860	10,410	60,225	24,065	0.35
SM12013ARO	120	146	129.7	136.3	139.6	22,505	10,875	64,965	25,330	0.38
SM13013ARO	130	156	139.7	146.3	149.6	24,710	11,475	71,300	26,955	0.41
SM14013ARO	140	166	149.7	156.3	159.5	26,355	11,920	76,060	28,135	0.44
SM15013ARO	150	176	159.7	166.3	169.5	28,000	12,345	80,820	29,290	0.46
SM16013ARO	160	186	169.7	176.3	179.5	29,645	12,765	85,580	30,445	0.49
SM17013ARO	170	196	179.7	186.3	189.5	31,290	13,165	90,315	31,535	0.52
SM18013ARO	180	206	189.7	196.3	199.5	32,935	13,545	95,075	32,650	0.55
SM19013ARO	190	216	199.7	206.3	209.5	34,585	13,945	99,835	33,715	0.58
SM20013ARO	200	226	209.7	216.3	219.4	36,765	14,480	106,175	35,140	0.61
SM25013ARO	250	276	259.7	266.3	269.4	45,015	16,255	129,950	40,210	0.75
SM30013ARO	300	326	309.7	316.3	319.3	53,800	18,035	155,300	45,280	0.89
SM32013ARO	320	346	329.7	336.3	339.3	57,090	18,680	164,800	47,105	0.95
SM34013ARO	340	366	349.7	356.3	359.2	60,915	19,395	175,895	49,195	1.01
SM36013ARO	360	386	369.7	376.3	379.2	64,230	19,995	185,415	50,950	1.06

Brass; one piece pocket separator
standard 1/4" balls

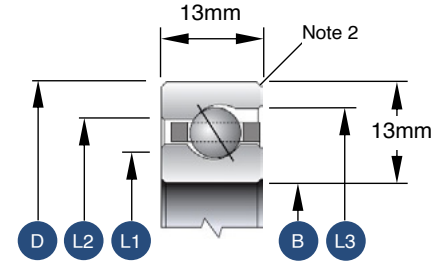

1. Load capacities are not additive
2. The maximum shaft or housing fillet radius that the bearing corners will clear for this series is 1.5mm
3. Race Width Tolerance: +0.000 -0.127mm



SM20 SERIES 20MM X 20MM

SILVERTHIN PART NUMBER	DIMENSIONS IN MILLIMETERS					CAPACITIES IN NEWTONS				APPROX WEIGHT KG
	BORE DIAMETER "B"	OUTSIDE DIAMETER "D"	LAND DIAMETER "L1"	LAND DIAMETER "L2"	LAND DIAMETER "L3"	RADIAL		THRUST		
						STATIC	DYNAMIC	STATIC	DYNAMIC	
SM11020ARO	110	150	125.0	135.0	140.0	34,585	19,660	99,835	44,190	0.94
SM12020ARO	120	160	135.0	145.0	150.0	37,050	20,395	106,975	46,280	1.01
SM13020ARO	130	170	145.0	155.0	160.0	39,520	21,130	114,090	48,305	1.08
SM14020ARO	140	180	155.0	165.0	170.0	41,990	21,840	121,230	50,305	1.15
SM15020ARO	150	190	165.0	175.0	180.0	45,705	22,930	131,930	53,220	1.20
SM16020ARO	160	200	175.0	185.0	190.0	48,170	23,595	139,045	55,110	1.30
SM17020ARO	170	210	185.0	195.0	200.0	50,465	24,265	146,185	56,980	1.40
SM18020ARO	180	220	195.0	205.0	210.0	53,110	24,910	153,300	58,825	1.50
SM19020ARO	190	230	205.0	215.0	220.0	55,580	25,555	160,440	60,625	1.50
SM20020ARO	200	240	215.0	225.0	230.0	59,270	26,530	171,135	63,295	1.60
SM25020ARO	250	290	265.0	275.0	280.0	72,880	29,825	210,370	72,635	2.10
SM30020ARO	300	340	315.0	325.0	330.0	85,225	32,535	246,020	80,620	2.30
SM32020ARO	320	360	335.0	345.0	350.0	91,405	33,870	263,855	84,490	2.42
SM34020ARO	340	380	355.0	365.0	370.0	96,345	34,870	278,110	87,490	2.54
SM36020ARO	360	400	375.0	385.0	390.0	102,505	36,140	295,925	91,205	2.70

Brass; one piece pocket separator
standard 3/8" balls

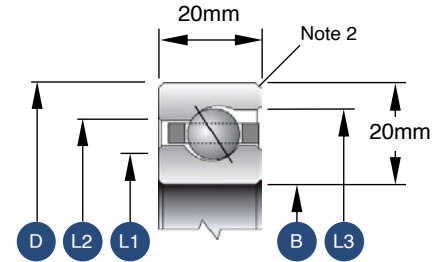

1. Load capacities are not additive
2. The maximum shaft or housing fillet radius that the bearing corners will clear for this series is 1.5mm
3. Race Width Tolerance: +0.000-0.127mm



Metric Open Type C

Radial Contact Bearings



The Type C, radial contact ball bearing is designed with deep ball grooves to withstand high loads. Although this bearing is used primarily in applications with radial loads, it can withstand moderate axial loads, reversing axial loads, and moment loads.

Contact Silverthin™ for radial bearing use with combined radial loads, with axial or moment loading, and for limiting speeds and separator selection.

LOAD CONDITION				
RADIAL	AXIAL	MOMENT	REVERSING AXIAL	COMBINED RADIAL-THRUST
Excellent	Good	Good (Light Loading)	Good (Light Loading)	Good

SM08 SERIES 8MM X 8MM

SILVERTHIN PART NUMBER	DIMENSIONS IN MILLIMETERS				CAPACITIES IN NEWTONS		APPROX WEIGHT KG
	BORE DIAMETER "B"	OUTSIDE DIAMETER "D"	LAND DIAMETER "L1"	LAND DIAMETER "L2"	RADIAL		
					STATIC	DYNAMIC	
SM02508CP0	25	41	30.9	35.1	2,980	2,490	0.06
SM05008CP0	50	66	55.9	60.1	5,450	3,425	0.08
SM06008CP0	60	76	65.9	70.1	6,425	3,760	0.09
SM07008CP0	70	86	75.9	80.1	7,430	4,090	0.10
SM08008CP0	80	96	85.9	90.1	8,430	4,405	0.12
SM09008CP0	90	106	95.9	100.1	9,410	4,695	0.13
SM10008CP0	100	116	105.9	110.1	10,410	4,980	0.14
SM11008CP0	110	126	115.9	120.1	11,385	5,225	0.15
SM12008CP0	120	136	125.9	130.1	12,365	5,495	0.16
SM13008CP0	130	146	135.9	140.1	13,365	5,760	0.17
SM14008CP0	140	156	145.9	150.1	14,365	6,005	0.18
SM15008CP0	150	166	155.9	160.1	15,345	6,250	0.20
SM16008CP0	160	176	165.9	170.1	16,345	6,495	0.20
SM17008CP0	170	186	175.9	180.1	17,325	6,715	0.21
SM18008CP0	180	196	185.9	190.1	18,325	6,960	0.22
SM19008CP0	190	206	195.9	200.1	19,060	7,115	0.23
SM20008CP0	200	216	205.9	210.1	20,060	7,340	0.23
SM25008CP0	250	266	255.9	260.1	25,000	8,360	0.28
SM30008CP0	300	316	305.9	310.1	29,955	9,295	0.33
SM32008CP0	320	336	325.9	330.1	31,935	9,650	0.36
SM34008CP0	340	356	345.9	350.1	33,915	9,965	0.38
SM36008CP0	360	376	365.9	370.1	35,650	10,295	0.40

Brass; snapover separator standard
5/32" balls

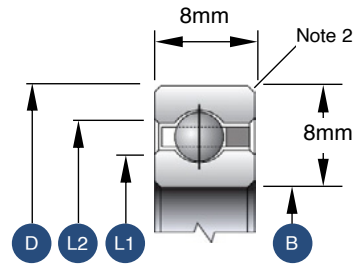

1. Load capacities are not additive
2. The maximum shaft or housing fillet radius that the bearing corners will clear for this series is 0.8mm
3. Race Width Tolerance: +0.000 -0.127mm

SM13 SERIES 13MM X 13MM

SILVERTHIN PART NUMBER	DIMENSIONS IN MILLIMETERS				CAPACITIES IN NEWTONS		APPROX WEIGHT KG
	BORE DIAMETER "B"	OUTSIDE DIAMETER "D"	LAND DIAMETER "L1"	LAND DIAMETER "L2"	RADIAL		
					STATIC	DYNAMIC	
SM08013CPO	80	106	89.7	96.3	13,320	8,450	0.26
SM09013CPO	90	116	99.7	106.3	15,210	9,140	0.29
SM10013CPO	100	126	109.7	116.3	16,480	9,520	0.32
SM11013CPO	110	136	119.7	126.3	18,390	10,140	0.35
SM12013CPO	120	146	129.7	136.3	19,660	10,520	0.38
SM13013CPO	130	156	139.7	146.3	20,930	10,875	0.41
SM14013CPO	140	166	149.7	156.3	22,820	11,455	0.44
SM15013CPO	150	176	159.7	166.3	24,085	11,810	0.46
SM16013CPO	160	186	169.7	176.3	25,355	12,145	0.49
SM17013CPO	170	196	179.7	186.3	27,265	12,700	0.52
SM18013CPO	180	206	189.7	196.3	28,535	13,010	0.55
SM19013CPO	190	216	199.7	206.3	29,800	13,345	0.58
SM20013CPO	200	226	209.7	216.3	31,690	13,835	0.61
SM25013CPO	250	276	259.7	266.3	39,300	15,680	0.75
SM30013CPO	300	326	309.7	316.3	46,280	17,190	0.89
SM32013CPO	320	346	329.7	336.3	49,440	17,880	0.95
SM34013CPO	340	366	349.7	356.3	52,620	18,525	1.01
SM36013CPO	360	386	369.7	376.3	55,780	19,170	1.06

Brass; snapover separator standard
1/4" balls

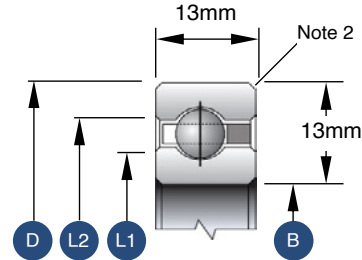

1. Load capacities are not additive
2. The maximum shaft or housing fillet radius that the bearing corners will clear for this series is 1.5mm
3. Race Width Tolerance: +0.000 -0.127mm



SM20 SERIES 20MM X 20MM

SILVERTHIN PART NUMBER	DIMENSIONS IN MILLIMETERS				CAPACITIES IN NEWTONS		APPROX WEIGHT KG
	BORE DIAMETER "B"	OUTSIDE DIAMETER "D"	LAND DIAMETER "L1"	LAND DIAMETER "L2"	RADIAL		
					STATIC	DYNAMIC	
SM11020CP0	110	150	125.0	135.0	28,535	18,435	0.94
SM12020CP0	120	160	135.0	145.0	31,380	19,440	1.01
SM13020CP0	130	170	145.0	155.0	32,805	19,840	1.08
SM14020CP0	140	180	155.0	165.0	35,650	20,795	1.15
SM15020CP0	150	190	165.0	175.0	37,075	21,195	1.20
SM16020CP0	160	200	175.0	185.0	39,920	22,105	1.30
SM17020CP0	170	210	185.0	195.0	42,790	22,485	1.40
SM18020CP0	180	220	195.0	205.0	44,215	23,375	1.50
SM19020CP0	190	230	205.0	215.0	47,060	24,220	1.50
SM20020CP0	200	240	215.0	225.0	48,485	24,575	1.60
SM25020CP0	250	290	265.0	275.0	59,890	27,665	2.10
SM30020CP0	300	340	315.0	325.0	71,300	30,515	2.30
SM32020CP0	320	360	335.0	345.0	75,595	31,515	2.42
SM34020CP0	340	380	355.0	365.0	79,865	32,470	2.54
SM36020CP0	360	400	375.0	385.0	84,155	33,425	2.70

Brass; snapover separator standard
3/8" balls

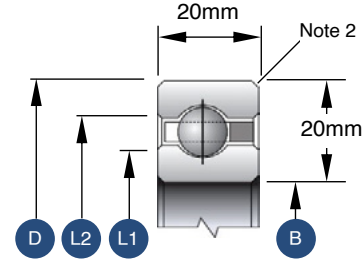

1. Load capacities are not additive
2. The maximum shaft or housing fillet radius that the bearing corners will clear for this series is 1.5mm
3. Race Width Tolerance: +0.000-0.127mm



Metric Open Type X

4-Point Contact Bearings



The Type X, or 4-point contact, ball bearing is ideal for moment loading. Type X bearings are designed with gothic arch raceways creating 4 contact points between the balls and the raceways. This design is excellent for moment loading and reversing axial loading.

The Type X bearing can be used for other light loading conditions, but is not recommended in place of the C- or Type A bearing for pure radial loads. Contact Silverthin™ for information on combined load and limiting speeds.

LOAD CONDITION				
RADIAL	AXIAL	MOMENT	REVERSING AXIAL	COMBINED RADIAL-THRUST
Poor	Good	Excellent	Excellent	Poor

SM08 SERIES 8MM X 8MM

SILVERTHIN PART NUMBER	DIMENSIONS IN MILLIMETERS				CAPACITIES IN NEWTONS						APPROX WEIGHT KG
	BORE DIAMETER "B"	OUTSIDE DIAMETER "D"	LAND DIAMETER "L1"	LAND DIAMETER "L2"	RADIAL		THRUST		MOMENT (N-M)		
					STATIC	DYNAMIC	STATIC	DYNAMIC	STATIC	DYNAMIC	
SM02508XPO	25	41	30.9	35.1	3,270	3,245	7,430	4,605	50	40	0.06
SM05008XPO	50	66	55.9	60.1	5,450	4,515	13,610	6,540	160	100	0.08
SM06008XPO	60	76	65.9	70.1	6,425	4,960	16,100	7,295	220	125	0.09
SM07008XPO	70	86	75.9	80.1	7,430	5,380	18,570	8,030	290	160	0.10
SM08008XPO	80	96	85.9	90.1	8,430	5,805	21,040	8,720	370	190	0.12
SM09008XPO	90	106	95.9	100.1	9,410	6,185	23,530	9,410	460	230	0.13
SM10008XPO	100	116	105.9	110.1	10,385	6,560	26,000	10,050	560	265	0.14
SM11008XPO	110	126	115.9	120.1	11,385	6,940	28,465	10,695	670	305	0.15
SM12008XPO	120	136	125.9	130.1	12,365	7,295	30,960	11,300	790	350	0.16
SM13008XPO	130	146	135.9	140.1	13,365	7,630	33,425	11,875	925	395	0.17
SM14008XPO	140	156	145.9	150.1	14,365	7,960	35,895	12,455	1,065	440	0.18
SM15008XPO	150	166	155.9	160.1	15,345	8,295	38,385	13,035	1,215	490	0.20
SM16008XPO	160	176	165.9	170.1	16,345	8,605	40,855	13,590	1,375	545	0.20
SM17008XPO	170	186	175.9	180.1	17,325	8,920	43,325	14,120	1,545	595	0.21
SM18008XPO	180	196	185.9	190.1	18,325	9,230	45,815	14,655	1,720	650	0.22
SM19008XPO	190	206	195.9	200.1	19,060	9,450	47,660	15,055	1,890	700	0.23
SM20008XPO	200	216	205.9	210.1	20,060	9,720	50,130	15,570	2,085	760	0.23
SM25008XPO	250	266	255.9	260.1	25,000	11,120	62,515	18,035	3,225	1,075	0.28
SM30008XPO	300	316	305.9	310.1	29,955	12,365	74,905	20,350	4,615	1,430	0.33
SM32008XPO	320	336	325.9	330.1	31,935	12,475	79,840	21,240	5,240	1,580	0.36
SM34008XPO	340	356	345.9	350.1	33,915	13,235	84,800	22,105	5,860	1,730	0.38
SM36008XPO	360	376	365.9	370.1	35,675	13,700	89,140	22,840	6,560	1,890	0.40

Brass; snapover separator standard 5/32" balls

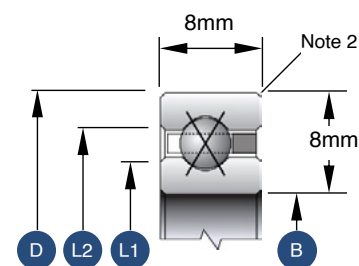

1. Load capacities are not additive
2. The maximum shaft or housing fillet radius that the bearing corners will clear for this series is 0.8mm
3. Race Width Tolerance: +0.000-0.127mm



SM13 SERIES 13MM X 13MM

SILVERTHIN PART NUMBER	DIMENSIONS IN MILLIMETERS				CAPACITIES IN NEWTONS						APPROX WEIGHT KG
	BORE DIAMETER "B"	OUTSIDE DIAMETER "D"	LAND DIAMETER "L1"	LAND DIAMETER "L2"	RADIAL		THRUST		MOMENT (N-M)		
					STATIC	DYNAMIC	STATIC	DYNAMIC	STATIC	DYNAMIC	
SM08013XP0	80	106	89.7	96.3	13,320	11,120	33,270	16,215	620	390	0.26
SM09013XP0	90	116	99.7	106.3	15,210	12,010	38,030	17,725	785	465	0.29
SM10013XP0	100	126	109.7	116.3	16,480	12,545	41,190	18,680	930	530	0.32
SM11013XP0	110	136	119.7	126.3	18,390	13,365	45,950	20,105	1,130	615	0.35
SM12013XP0	120	146	129.7	136.3	19,660	13,880	49,130	21,015	1,305	695	0.38
SM13013XP0	130	156	139.7	146.3	20,930	14,365	52,285	21,905	1,495	770	0.41
SM14013XP0	140	166	149.7	156.3	22,820	15,145	57,045	23,220	1,745	870	0.44
SM15013XP0	150	176	159.7	166.3	24,085	15,610	60,225	24,065	1,965	955	0.46
SM16013XP0	160	186	169.7	176.3	25,355	16,080	63,385	24,910	2,195	1,045	0.49
SM17013XP0	170	196	179.7	186.3	27,265	16,770	68,145	26,155	2,495	1,150	0.52
SM18013XP0	180	206	189.7	196.3	28,535	17,215	71,300	26,955	2,755	1,245	0.55
SM19013XP0	190	216	199.7	206.3	29,800	17,660	74,480	27,735	3,025	1,345	0.58
SM20013XP0	200	226	209.7	216.3	31,690	18,325	79,240	28,910	3,375	1,465	0.61
SM25013XP0	250	276	259.7	266.3	39,300	20,770	98,255	33,360	5,170	2,050	0.75
SM30013XP0	300	326	309.7	316.3	46,280	22,820	115,670	37,210	7,240	2,680	0.89
SM32013XP0	320	346	329.7	336.3	49,440	23,730	123,610	38,900	8,230	2,965	0.95
SM34013XP0	340	366	349.7	356.3	52,620	24,595	131,525	40,520	9,285	3,255	1.01
SM36013XP0	360	386	369.7	376.3	55,780	25,445	139,445	42,145	10,405	3,560	1.06

Brass; snapover separator standard 1/4" balls

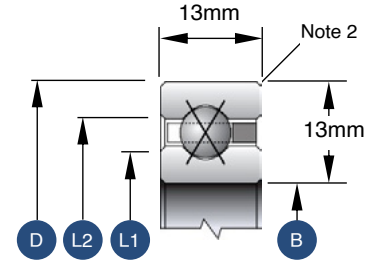

1. Load capacities are not additive
2. The maximum shaft or housing fillet radius that the bearing corners will clear for this series is 1.5mm
3. Race Width Tolerance: +0.000 -0.127mm



SM20 SERIES 20MM X 20MM

SILVERTHIN PART NUMBER	DIMENSIONS IN MILLIMETERS				CAPACITIES IN NEWTONS						APPROX WEIGHT KG
	BORE DIAMETER "B"	OUTSIDE DIAMETER "D"	LAND DIAMETER "L1"	LAND DIAMETER "L2"	RADIAL		THRUST		MOMENT (N-M)		
					STATIC	DYNAMIC	STATIC	DYNAMIC	STATIC	DYNAMIC	
SM11020XP0	110	150	125.0	135.0	28,535	24,175	71,300	35,315	1,855	1,180	0.94
SM12020XP0	120	160	135.0	145.0	31,380	25,530	78,440	37,630	2,195	1,340	1.01
SM13020XP0	130	170	145.0	155.0	32,805	26,090	82,000	38,765	2,460	1,470	1.08
SM14020XP0	140	180	155.0	165.0	35,650	27,375	89,140	40,990	2,850	1,645	1.15
SM15020XP0	150	190	165.0	175.0	37,075	27,890	92,695	42,080	3,150	1,780	1.20
SM16020XP0	160	200	175.0	185.0	39,920	29,135	99,835	44,190	3,595	1,965	1.30
SM17020XP0	170	210	185.0	195.0	42,790	29,645	106,950	46,280	3,930	2,115	1.40
SM18020XP0	180	220	195.0	205.0	44,215	30,825	110,535	47,305	4,420	2,310	1.50
SM19020XP0	190	230	205.0	215.0	47,060	31,960	117,670	49,305	4,940	2,520	1.50
SM20020XP0	200	240	215.0	225.0	48,485	32,450	121,230	50,305	5,335	2,680	1.60
SM25020XP0	250	290	265.0	275.0	59,890	36,585	149,740	57,915	8,085	3,705	2.10
SM30020XP0	300	340	315.0	325.0	71,300	40,390	178,275	65,050	11,410	4,850	2.30
SM32020XP0	320	360	335.0	345.0	75,595	41,720	188,975	67,630	12,850	5,325	2.42
SM34020XP0	340	380	355.0	365.0	79,865	43,035	199,670	70,145	14,375	5,810	2.54
SM36020XP0	360	400	375.0	385.0	84,155	44,300	210,370	72,635	15,985	6,315	2.70

Brass; snapover separator standard
3/8" balls

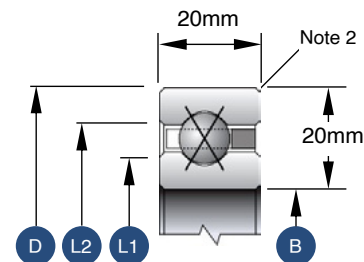

1. Load capacities are not additive
2. The maximum shaft or housing fillet radius that the bearing corners will clear for this series is 1.5mm
3. Race Width Tolerance: +0.000-0.127mm

While Silverthin is the premier source for Made in the USA Thin Section Bearings, sometimes they are just not thin enough. Some applications require even lighter, thinner bearings. In those cases Silverthin Extra Thin Section Bearings represent a unique option. All of these parts are made in the same internal design configurations as Silverthin Thin Section bearings, and all are Made in the USA:

- Type A (Angular Contact – 30°)
- Type C (Radial)
- Type X (Four Point Contact – 30°)

Aside from being Extra Thin, the cross-sections are not square. They come in two constant cross-section, variable ID sizes:

- 2.5mm Wide x 3mm High
- Standard with no cage

These bearings provide a unique solution for small spaces and provide less torque than more common bushing or plain bearings that may be used. It is recommended that Silverthin Engineering be consulted by any designer wanting to use Silverthin Extra Thin Section bearings. Their unique geometry requires extra considerations.



TYPE A - EXTRA THIN BEARINGS

SILVERTHIN PART NUMBER	DIMENSIONS IN MILLIMETERS				CAPACITIES IN NEWTONS			APPROX WEIGHT GRAMS
	BORE DIAMETER "B"	OUTSIDE DIAMETER "D"	LAND DIAMETER "L1"	LAND DIAMETER "L2"	RADIAL		THRUST	
					STATIC	DYNAMIC	STATIC	
SSM03503AS0	35	41	37.2	38.8	385	385	670	5
SSM06003AS0	60	66	62.2	63.8	650	550	690	9
SSM07003AS0	70	76	72.2	73.8	750	610	710	11
SSM07403AS0	74	80	76.2	77.8	800	630	735	11
SSM08003AS0	80	86	82.2	83.8	865	660	775	12
SSM09003AS0	90	96	92.2	93.8	970	715	825	13
SSM10003AS0	100	106	102.2	103.8	1,075	765	865	15

Full complement or spacer balls standard 1/16" balls

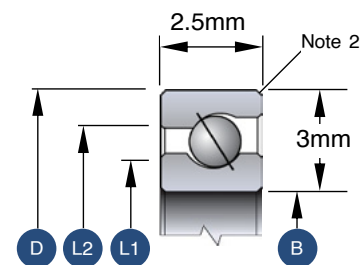

1. Load capacities are not additive
2. The maximum shaft or housing fillet radius that the bearing corners will clear for this series is 0.25mm
3. Race Width Tolerance: +0.000 -0.127mm

TYPE C - EXTRA THIN BEARINGS

SILVERTHIN PART NUMBER	DIMENSIONS IN MILLIMETERS				CAPACITIES IN NEWTONS		APPROX WEIGHT GRAMS
	BORE DIAMETER "B"	OUTSIDE DIAMETER "D"	LAND DIAMETER "L1"	LAND DIAMETER "L2"	RADIAL		
					STATIC	DYNAMIC	
SSM03503CS0	35	41	37.2	38.8	420	420	5
SSM06003CS0	60	66	62.2	63.8	710	605	9
SSM07003CS0	70	76	72.2	73.8	825	670	11
SSM07403CS0	74	80	76.2	77.8	875	690	11
SSM08003CS0	80	86	82.2	83.8	945	725	12
SSM09003CS0	90	96	92.2	93.8	1,060	785	13
SSM10003CS0	100	106	102.2	103.8	1,180	840	15

Full complement or spacer balls standard
1/16" balls

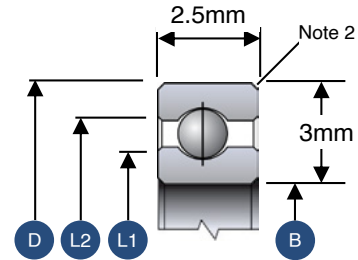

1. Load capacities are not additive
2. The maximum shaft or housing fillet radius that the bearing corners will clear for this series is 0.25mm
3. Race Width Tolerance: +0.000 -0.127mm



TYPE X - EXTRA THIN BEARINGS

SILVERTHIN PART NUMBER	DIMENSIONS IN MILLIMETERS				CAPACITIES IN NEWTONS				APPROX WEIGHT GRAMS
	BORE DIAMETER "B"	OUTSIDE DIAMETER "D"	LAND DIAMETER "L1"	LAND DIAMETER "L2"	RADIAL		THRUST	MOMENT (N-M)	
					STATIC	DYNAMIC	STATIC	STATIC	
SSM03503XS0	35	41	37.2	38.8	710	585	555	7.9	5
SSM06003XS0	60	66	62.2	63.8	1,210	850	575	11.8	9
SSM07003XS0	70	76	72.2	73.8	1,410	935	600	13	11
SSM07403XS0	74	80	76.2	77.8	1,490	965	625	13.4	11
SSM08003XS0	80	86	82.2	83.8	1,605	1,015	645	14	12
SSM09003XS0	90	96	92.2	93.8	1,805	1,095	690	14.9	13
SSM10003XS0	100	106	102.2	103.8	2,005	1,180	735	15.6	15

Full complement or spacer balls standard
1/16" balls

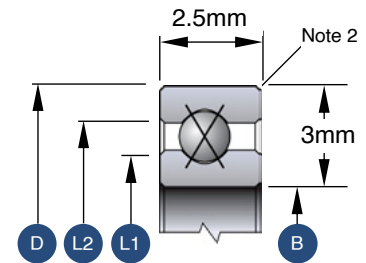

1. Load capacities are not additive
2. The maximum shaft or housing fillet radius that the bearing corners will clear for this series is 0.25mm
3. Race Width Tolerance: +0.000 -0.127mm



Metric Duplex Type B

Back-to-Back Paired Angular Contact Bearings



SM08 SERIES 8MM X 8MM

SILVERTHIN PART NUMBER	DIMENSIONS IN MILLIMETERS				CAPACITIES IN NEWTONS						APPROX WEIGHT KG
	BORE DIAMETER "B"	OUTSIDE DIAMETER "D"	LAND DIAMETER "L1"	LAND DIAMETER "L3"	RADIAL		THRUST		MOMENT (N-M)		
					STATIC	DYNAMIC	STATIC	DYNAMIC	STATIC	DYNAMIC	
SM02508BRO	25	41	30.9	37.2	5,920	4,340	10,520	5,495	95	70	0.12
SM05008BRO	50	66	55.9	62.2	10,440	5,860	18,570	8,030	270	150	0.16
SM06008BRO	60	76	65.9	72.2	12,540	6,510	22,285	9,075	365	190	0.18
SM07008BRO	70	86	75.9	82.2	14,280	7,010	25,375	9,895	470	230	0.20
SM08008BRO	80	96	85.9	92.2	16,050	7,480	28,465	10,695	585	275	0.24
SM09008BRO	90	106	95.9	102.2	18,100	8,060	32,180	11,585	720	320	0.26
SM10008BRO	100	116	105.9	112.2	19,840	8,490	35,275	12,320	860	370	0.28
SM11008BRO	110	126	115.9	122.2	21,610	8,930	38,385	13,035	1,020	420	0.30
SM12008BRO	120	136	125.9	132.2	23,340	9,360	41,480	13,720	1,190	475	0.32
SM13008BRO	130	146	135.9	142.2	25,440	9,860	45,190	14,525	1,375	530	0.34
SM14008BRO	140	156	145.9	152.2	27,180	10,260	48,285	15,190	1,570	590	0.36
SM15008BRO	150	166	155.9	162.2	28,910	10,630	51,375	15,835	1,780	650	0.40
SM16008BRO	160	176	165.9	172.2	31,010	11,100	55,090	16,590	2,000	715	0.40
SM17008BRO	170	186	175.9	182.2	32,740	11,460	58,180	17,190	2,240	780	0.42
SM18008BRO	180	196	185.9	192.2	34,520	11,810	61,270	17,815	2,485	850	0.44
SM19008BRO	190	206	195.9	202.2	36,570	12,250	64,985	18,525	2,750	920	0.46
SM20008BRO	200	216	205.9	212.2	38,310	12,610	68,100	19,105	3,025	990	0.46
SM25008BRO	250	266	255.9	262.2	47,380	14,310	84,180	21,995	4,595	1,385	0.56
SM30008BRO	300	316	305.9	312.2	56,780	15,900	100,905	24,820	6,500	1,820	0.66
SM32008BRO	320	336	325.9	332.2	60,650	16,550	107,710	25,930	7,350	2,010	0.72
SM34008BRO	340	356	345.9	352.2	64,110	17,100	113,890	26,910	8,260	2,200	0.76
SM36008BRO	360	376	365.9	372.2	67,940	17,670	120,695	27,980	9,215	2,395	0.80

Brass; one piece pocket separator
standard 5/32" balls

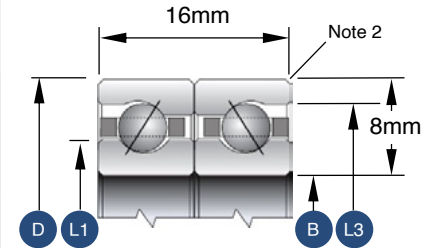

1. Load capacities are not additive
2. The maximum shaft or housing fillet radius that the bearing corners will clear for this series is 0.8mm
3. Race Width Tolerance: +0.000-0.254mm

Metric Duplex Type B

Back-to-Back Paired Angular Contact Bearings



SM13 SERIES 13MM X 13MM

SILVERTHIN PART NUMBER	DIMENSIONS IN MILLIMETERS				CAPACITIES IN NEWTONS						APPROX WEIGHT KG
	BORE DIAMETER "B"	OUTSIDE DIAMETER "D"	LAND DIAMETER "L1"	LAND DIAMETER "L3"	RADIAL		THRUST		MOMENT (N-M)		
					STATIC	DYNAMIC	STATIC	DYNAMIC	STATIC	DYNAMIC	
SM08013BRO	80	106	89.7	99.6	25,880	14,570	45,950	20,105	1,050	595	0.52
SM09013BRO	90	116	99.7	109.6	28,550	15,360	50,705	21,485	1,270	685	0.58
SM10013BRO	100	126	109.7	119.6	31,220	16,150	55,465	22,795	1,515	780	0.64
SM11013BRO	110	136	119.7	129.6	33,900	16,920	60,225	24,065	1,775	880	0.70
SM12013BRO	120	146	129.7	139.6	36,570	17,670	64,965	25,330	2,050	985	0.76
SM13013BRO	130	156	139.7	149.6	40,150	18,650	71,300	26,955	2,350	1,095	0.82
SM14013BRO	140	166	149.7	159.5	42,830	19,370	76,060	28,135	2,665	1,205	0.88
SM15013BRO	150	176	159.7	169.5	45,500	20,060	80,820	29,290	3,000	1,320	0.92
SM16013BRO	160	186	169.7	179.5	48,170	20,740	85,580	30,445	3,355	1,440	0.98
SM17013BRO	170	196	179.7	189.5	50,850	21,390	90,315	31,535	3,730	1,565	1.04
SM18013BRO	180	206	189.7	199.5	53,520	22,010	95,075	32,650	4,125	1,695	1.10
SM19013BRO	190	216	199.7	209.5	56,200	22,660	99,835	33,715	4,540	1,825	1.16
SM20013BRO	200	226	209.7	219.4	59,740	23,530	106,175	35,140	4,970	1,960	1.22
SM25013BRO	250	276	259.7	269.4	73,150	26,410	129,950	40,210	7,430	2,685	1.50
SM30013BRO	300	326	309.7	319.3	87,430	29,310	155,300	45,280	10,400	3,495	1.78
SM32013BRO	320	346	329.7	339.3	92,770	30,360	164,800	47,105	11,735	3,840	1.90
SM34013BRO	340	366	349.7	359.2	98,990	31,520	175,895	49,195	13,155	4,195	2.02
SM36013BRO	360	386	369.7	379.2	104,370	32,490	185,415	50,950	14,655	4,560	2.12

Brass; one piece pocket separator
standard 1/4" balls

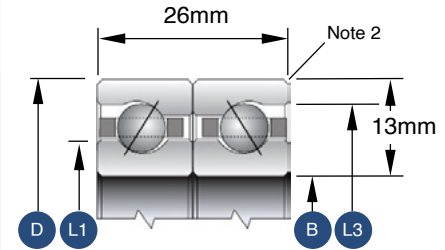

1. Load capacities are not additive
2. The maximum shaft or housing fillet radius that the bearing corners will clear for this series is 1.5mm
3. Race Width Tolerance: +0.000 -0.254mm

Metric Duplex Type B

Back-to-Back Paired Angular Contact Bearings



SM20 SERIES 20MM X 20MM

SILVERTHIN PART NUMBER	DIMENSIONS IN MILLIMETERS				CAPACITIES IN NEWTONS						APPROX WEIGHT KG
	BORE DIAMETER "B"	OUTSIDE DIAMETER "D"	LAND DIAMETER "L1"	LAND DIAMETER "L3"	RADIAL		THRUST		MOMENT (N-M)		
					STATIC	DYNAMIC	STATIC	DYNAMIC	STATIC	DYNAMIC	
SM11020BRO	110	150	125.0	140.0	56,200	31,950	99,835	44,190	3,255	1,860	1.88
SM12020BRO	120	160	135.0	150.0	60,210	33,140	106,975	46,280	3,730	2,055	2.02
SM13020BRO	130	170	145.0	160.0	64,220	34,340	114,090	48,305	4,240	2,260	2.16
SM14020BRO	140	180	155.0	170.0	68,230	35,490	121,230	50,305	4,780	2,475	2.30
SM15020BRO	150	190	165.0	180.0	74,270	37,260	131,930	53,220	5,350	2,690	2.40
SM16020BRO	160	200	175.0	190.0	78,280	38,340	139,045	55,110	5,950	2,920	2.60
SM17020BRO	170	210	185.0	200.0	82,010	39,430	146,185	56,980	6,580	3,150	2.80
SM18020BRO	180	220	195.0	210.0	86,300	40,480	153,300	58,825	7,245	3,390	3.00
SM19020BRO	190	230	205.0	220.0	90,320	41,530	160,440	60,625	7,935	3,635	3.00
SM20020BRO	200	240	215.0	230.0	96,310	43,110	171,135	63,295	8,660	3,885	3.20
SM25020BRO	250	290	265.0	280.0	118,430	48,470	210,370	72,635	12,750	5,225	4.20
SM30020BRO	300	340	315.0	330.0	138,490	52,870	246,020	80,620	17,625	6,710	4.60
SM32020BRO	320	360	335.0	350.0	148,530	55,040	263,855	84,490	19,800	7,335	4.84
SM34020BRO	340	380	355.0	370.0	156,560	56,660	278,110	87,490	22,100	7,985	5.08
SM36020BRO	360	400	375.0	390.0	166,570	58,730	295,925	91,205	24,525	8,645	5.40

Brass; one piece pocket separator
standard 3/8" balls

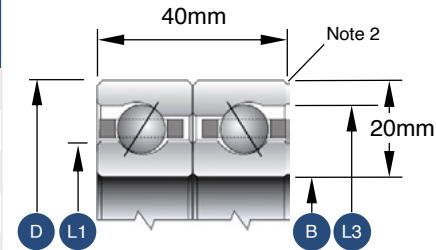

1. Load capacities are not additive
2. The maximum shaft or housing fillet radius that the bearing corners will clear for this series is 1.5mm
3. Race Width Tolerance: +0.000 -0.254mm

Metric Duplex Type F

Face-to-Face Paired Angular Contact Bearings



SM08 SERIES 8MM X 8MM

SILVERTHIN PART NUMBER	DIMENSIONS IN MILLIMETERS				CAPACITIES IN NEWTONS						APPROX WEIGHT KG
	BORE DIAMETER "B"	OUTSIDE DIAMETER "D"	LAND DIAMETER "L1"	LAND DIAMETER "L3"	RADIAL		THRUST		MOMENT (N-M)		
					STATIC	DYNAMIC	STATIC	DYNAMIC	STATIC	DYNAMIC	
SM02508FRO	25	41	30.9	35.1	5,920	4,340	10,520	5,495	340	240	0.12
SM05008FRO	50	66	55.9	60.1	10,440	5,860	18,570	8,030	1,470	840	0.16
SM06008FRO	60	76	65.9	70.1	12,540	6,510	22,285	9,075	2,125	1,125	0.18
SM07008FRO	70	86	75.9	80.1	14,280	7,010	25,375	9,895	2,895	1,440	0.20
SM08008FRO	80	96	85.9	90.1	16,050	7,480	28,465	10,695	3,780	1,775	0.24
SM09008FRO	90	106	95.9	100.1	18,100	8,060	32,180	11,585	4,780	2,140	0.26
SM10008FRO	100	116	105.9	110.1	19,840	8,490	35,275	12,320	5,895	2,530	0.28
SM11008FRO	110	126	115.9	120.1	21,610	8,930	38,385	13,035	7,130	2,945	0.30
SM12008FRO	120	136	125.9	130.1	23,340	9,360	41,480	13,720	8,475	3,385	0.32
SM13008FRO	130	146	135.9	140.1	25,440	9,860	45,190	14,525	9,940	3,845	0.34
SM14008FRO	140	156	145.9	150.1	27,180	10,260	48,285	15,190	11,515	4,330	0.36
SM15008FRO	150	166	155.9	160.1	28,910	10,630	51,375	15,835	13,210	4,840	0.40
SM16008FRO	160	176	165.9	170.1	31,010	11,100	55,090	16,590	15,020	5,365	0.40
SM17008FRO	170	186	175.9	180.1	32,740	11,460	58,180	17,190	16,950	5,915	0.42
SM18008FRO	180	196	185.9	190.1	34,520	11,810	61,270	17,815	18,990	6,485	0.44
SM19008FRO	190	206	195.9	200.1	36,570	12,250	64,985	18,525	21,150	7,075	0.46
SM20008FRO	200	216	205.9	210.1	38,310	12,610	68,100	19,105	23,425	7,690	0.46
SM25008FRO	250	266	255.9	260.1	47,380	14,310	84,180	21,995	36,540	11,015	0.56
SM30008FRO	300	316	305.9	310.1	56,780	15,900	100,905	24,820	52,570	14,755	0.66
SM32008FRO	320	336	325.9	330.1	60,650	16,550	107,710	25,930	59,800	16,350	0.72
SM34008FRO	340	356	345.9	350.1	64,110	17,100	113,890	26,910	67,495	17,995	0.76
SM36008FRO	360	376	365.9	370.1	67,940	17,670	120,695	27,980	75,660	19,690	0.80

Brass; one piece pocket separator
standard 5/32" balls

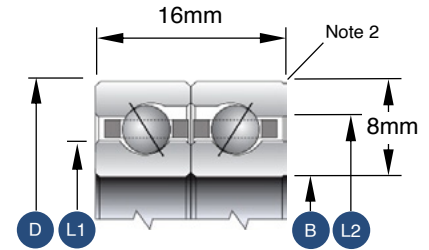

1. Load capacities are not additive
2. The maximum shaft or housing fillet radius that the bearing corners will clear for this series is 0.8mm
3. Race Width Tolerance: +0.000 -0.254mm

Metric Duplex Type F

Face-to-Face Paired Angular Contact Bearings



SM13 SERIES 13MM X 13MM

SILVERTHIN PART NUMBER	DIMENSIONS IN MILLIMETERS				CAPACITIES IN NEWTONS						APPROX WEIGHT KG
	BORE DIAMETER "B"	OUTSIDE DIAMETER "D"	LAND DIAMETER "L1"	LAND DIAMETER "L2"	RADIAL		THRUST		MOMENT (N-M)		
					STATIC	DYNAMIC	STATIC	DYNAMIC	STATIC	DYNAMIC	
SM08013FRO	80	106	89.7	96.3	25,880	14,570	45,950	20,105	5,755	3,190	0.52
SM09013FRO	90	116	99.7	106.3	28,550	15,360	50,705	21,485	7,360	3,885	0.58
SM10013FRO	100	126	109.7	116.3	31,220	16,150	55,465	22,795	9,145	4,620	0.64
SM11013FRO	110	136	119.7	126.3	33,900	16,920	60,225	24,065	11,100	5,395	0.70
SM12013FRO	120	146	129.7	136.3	36,570	17,670	64,965	25,330	13,235	6,205	0.76
SM13013FRO	130	156	139.7	146.3	40,150	18,650	71,300	26,955	15,550	7,055	0.82
SM14013FRO	140	166	149.7	156.3	42,830	19,370	76,060	28,135	18,040	7,940	0.88
SM15013FRO	150	176	159.7	166.3	45,500	20,060	80,820	29,290	20,715	8,865	0.92
SM16013FRO	160	186	169.7	176.3	48,170	20,740	85,580	30,445	23,575	9,825	0.98
SM17013FRO	170	196	179.7	186.3	50,850	21,390	90,315	31,535	26,620	10,820	1.04
SM18013FRO	180	206	189.7	196.3	53,520	22,010	95,075	32,650	29,855	11,855	1.10
SM19013FRO	190	216	199.7	206.3	56,200	22,660	99,835	33,715	33,275	12,920	1.16
SM20013FRO	200	226	209.7	216.3	59,740	23,530	106,175	35,140	36,885	14,020	1.22
SM25013FRO	250	276	259.7	266.3	73,150	26,410	129,950	40,210	57,865	20,005	1.50
SM30013FRO	300	326	309.7	316.3	87,430	29,310	155,300	45,280	83,865	26,760	1.78
SM32013FRO	320	346	329.7	336.3	92,770	30,360	164,800	47,105	95,720	29,660	1.90
SM34013FRO	340	366	349.7	356.3	98,990	31,520	175,895	49,195	108,430	32,670	2.02
SM36013FRO	360	386	369.7	376.3	104,370	32,490	185,415	50,950	122,000	35,780	2.12

Brass; one piece pocket separator
standard 1/4" balls

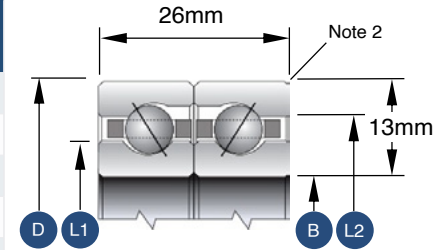

1. Load capacities are not additive
2. The maximum shaft or housing fillet radius that the bearing corners will clear for this series is 1.5mm
3. Race Width Tolerance: +0.000 -0.254mm

Metric Duplex Type F

Face-to-Face Paired Angular Contact Bearings



SM20 SERIES 20MM X 20MM

SILVERTHIN PART NUMBER	DIMENSIONS IN MILLIMETERS				CAPACITIES IN NEWTONS						APPROX WEIGHT KG
	BORE DIAMETER "B"	OUTSIDE DIAMETER "D"	LAND DIAMETER "L1"	LAND DIAMETER "L2"	RADIAL		THRUST		MOMENT (N-M)		
					STATIC	DYNAMIC	STATIC	DYNAMIC	STATIC	DYNAMIC	
SM11020FRO	110	150	125.0	135.0	56,200	31,950	99,835	44,190	16,650	9,515	1.88
SM12020FRO	120	160	135.0	145.0	60,210	33,140	106,975	46,280	19,920	10,980	2.02
SM13020FRO	130	170	145.0	155.0	64,220	34,340	114,090	48,305	23,455	12,510	2.16
SM14020FRO	140	180	155.0	165.0	68,230	35,490	121,230	50,305	27,260	14,110	2.30
SM15020FRO	150	190	165.0	175.0	74,270	37,260	131,930	53,220	31,335	15,770	2.40
SM16020FRO	160	200	175.0	185.0	78,280	38,340	139,045	55,110	35,685	17,500	2.60
SM17020FRO	170	210	185.0	195.0	82,010	39,430	146,185	56,980	40,305	19,290	2.80
SM18020FRO	180	220	195.0	205.0	86,300	40,480	153,300	58,825	45,195	21,140	3.00
SM19020FRO	190	230	205.0	215.0	90,320	41,530	160,440	60,625	50,365	23,050	3.00
SM20020FRO	200	240	215.0	225.0	96,310	43,110	171,135	63,295	55,805	25,020	3.20
SM25020FRO	250	290	265.0	275.0	118,430	48,470	210,370	72,635	87,160	35,735	4.20
SM30020FRO	300	340	315.0	325.0	138,490	52,870	246,020	80,620	125,490	47,765	4.60
SM32020FRO	320	360	335.0	345.0	148,530	55,040	263,855	84,490	142,800	52,915	4.84
SM34020FRO	340	380	355.0	365.0	156,560	56,660	278,110	87,490	161,240	58,245	5.08
SM36020FRO	360	400	375.0	385.0	166,570	58,730	295,925	91,205	180,825	63,750	5.40

Brass; one piece pocket separator
standard 3/8" balls

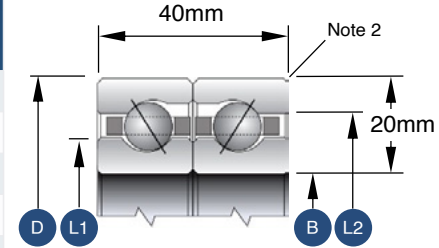

1. Load capacities are not additive
2. The maximum shaft or housing fillet radius that the bearing corners will clear for this series is 1.5mm
3. Race Width Tolerance: +0.000 -0.254mm

Metric Duplex Type T

Tandem Paired Angular Contact Bearings



SM08 SERIES 8MM X 8MM

SILVERTHIN PART NUMBER	DIMENSIONS IN MILLIMETERS					CAPACITIES IN NEWTONS				APPROX WEIGHT KG
	BORE DIAMETER "B"	OUTSIDE DIAMETER "D"	LAND DIAMETER "L1"	LAND DIAMETER "L2"	C'BORE DIAMETER "L3"	RADIAL		THRUST		
						STATIC	DYNAMIC	STATIC	DYNAMIC	
SM02508TRO	25	41	30.9	35.1	37.2	5,925	4,340	17,095	8,930	0.12
SM05008TRO	50	66	55.9	60.1	62.2	10,440	5,860	30,175	13,050	0.16
SM06008TRO	60	76	65.9	70.1	72.2	12,535	6,510	36,215	14,745	0.18
SM07008TRO	70	86	75.9	80.1	82.2	14,275	7,010	41,235	16,080	0.20
SM08008TRO	80	96	85.9	90.1	92.2	16,045	7,485	46,255	17,380	0.24
SM09008TRO	90	106	95.9	100.1	102.2	18,105	8,060	52,295	18,825	0.26
SM10008TRO	100	116	105.9	110.1	112.2	19,840	8,490	57,320	20,020	0.28
SM11008TRO	110	126	115.9	120.1	122.2	21,615	8,930	62,375	21,180	0.30
SM12008TRO	120	136	125.9	130.1	132.2	23,345	9,360	67,405	22,295	0.32
SM13008TRO	130	146	135.9	140.1	142.2	25,440	9,865	73,435	23,605	0.34
SM14008TRO	140	156	145.9	150.1	152.2	27,180	10,260	78,465	24,685	0.36
SM15008TRO	150	166	155.9	160.1	162.2	28,910	10,630	83,485	25,730	0.40
SM16008TRO	160	176	165.9	170.1	172.2	31,005	11,100	89,520	26,960	0.40
SM17008TRO	170	186	175.9	180.1	182.2	32,745	11,455	94,545	27,935	0.42
SM18008TRO	180	196	185.9	190.1	192.2	34,515	11,815	99,565	28,950	0.44
SM19008TRO	190	206	195.9	200.1	202.2	36,570	12,255	105,600	30,105	0.46
SM20008TRO	200	216	205.9	210.1	212.2	38,310	12,610	110,665	31,045	0.46
SM25008TRO	250	266	255.9	260.1	262.2	47,375	14,310	136,795	35,740	0.56
SM30008TRO	300	316	305.9	310.1	312.2	56,780	15,900	163,970	40,335	0.66
SM32008TRO	320	336	325.9	330.1	332.2	60,645	16,550	175,030	42,135	0.72
SM34008TRO	340	356	345.9	350.1	352.2	64,115	17,095	185,070	43,730	0.76
SM36008TRO	360	376	365.9	370.1	372.2	67,940	17,670	196,130	45,470	0.80

Brass; circular pocket separator
standard 5/32" balls

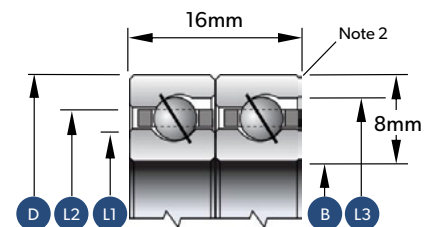

1. Load capacities are not additive
2. The maximum shaft or housing fillet radius that the bearing corners will clear for this series is 0.8mm
3. Race Width Tolerance: +0.000 -0.254mm

Metric Duplex Type T

Tandem Paired Angular Contact Bearings



SM13 SERIES 13MM X 13MM

SILVERTHIN PART NUMBER	DIMENSIONS IN MILLIMETERS					CAPACITIES IN NEWTONS				APPROX WEIGHT KG
	BORE DIAMETER "B"	OUTSIDE DIAMETER "D"	LAND DIAMETER "L1"	LAND DIAMETER "L2"	C'BORE DIAMETER "L3"	RADIAL		THRUST		
						STATIC	DYNAMIC	STATIC	DYNAMIC	
SM08013TRO	80	106	89.7	96.3	99.6	25,880	14,570	74,670	32,670	0.52
SM09013TRO	90	116	99.7	106.3	109.6	28,550	15,355	82,395	34,915	0.58
SM10013TRO	100	126	109.7	116.3	119.6	31,225	16,155	90,130	37,040	0.64
SM11013TRO	110	136	119.7	126.3	129.6	33,900	16,915	97,865	39,105	0.70
SM12013TRO	120	146	129.7	136.3	139.6	36,570	17,670	105,570	41,160	0.76
SM13013TRO	130	156	139.7	146.3	149.6	40,155	18,645	115,865	43,800	0.82
SM14013TRO	140	166	149.7	156.3	159.5	42,825	19,370	123,600	45,720	0.88
SM15013TRO	150	176	159.7	166.3	169.5	45,500	20,060	131,335	47,595	0.92
SM16013TRO	160	186	169.7	176.3	179.5	48,175	20,745	139,070	49,475	0.98
SM17013TRO	170	196	179.7	186.3	189.5	50,845	21,395	146,760	51,245	1.04
SM18013TRO	180	206	189.7	196.3	199.5	53,520	22,010	154,495	53,055	1.10
SM19013TRO	190	216	199.7	206.3	209.5	56,200	22,660	162,230	54,785	1.16
SM20013TRO	200	226	209.7	216.3	219.4	59,745	23,530	172,535	57,105	1.22
SM25013TRO	250	276	259.7	266.3	269.4	73,150	26,415	211,170	65,340	1.50
SM30013TRO	300	326	309.7	316.3	319.3	87,425	29,305	252,365	73,580	1.78
SM32013TRO	320	346	329.7	336.3	339.3	92,770	30,355	267,800	76,545	1.90
SM34013TRO	340	366	349.7	356.3	359.2	98,985	31,515	285,830	79,940	2.02
SM36013TRO	360	386	369.7	376.3	379.2	104,375	32,490	301,300	82,795	2.12

Brass; circular pocket separator
standard 1/4" balls

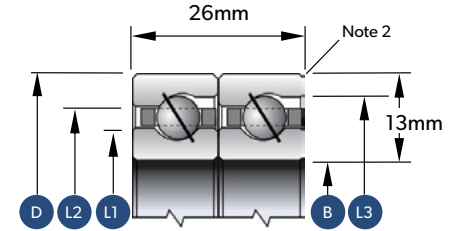

1. Load capacities are not additive
2. The maximum shaft or housing fillet radius that the bearing corners will clear for this series is 1.5mm
3. Race Width Tolerance: +0.000 -0.254mm

SM20 SERIES 20MM X 20MM

SILVERTHIN PART NUMBER	DIMENSIONS IN MILLIMETERS					CAPACITIES IN NEWTONS				APPROX WEIGHT KG
	BORE DIAMETER "B"	OUTSIDE DIAMETER "D"	LAND DIAMETER "L1"	LAND DIAMETER "L2"	C"BORE DIAMETER "L3"	RADIAL		THRUST		
						STATIC	DYNAMIC	STATIC	DYNAMIC	
SM11020TRO	110	150	125.0	135.0	140.0	56,200	31,950	162,230	71,810	1.88
SM12020TRO	120	160	135.0	145.0	150.0	60,205	33,140	173,835	75,205	2.02
SM13020TRO	130	170	145.0	155.0	160.0	64,220	34,335	185,395	78,495	2.16
SM14020TRO	140	180	155.0	165.0	170.0	68,235	35,490	197,000	81,745	2.30
SM15020TRO	150	190	165.0	175.0	180.0	74,270	37,260	214,385	86,485	2.40
SM16020TRO	160	200	175.0	185.0	190.0	78,275	38,340	225,950	89,555	2.60
SM17020TRO	170	210	185.0	195.0	200.0	82,005	39,430	237,550	92,595	2.80
SM18020TRO	180	220	195.0	205.0	210.0	86,305	40,480	249,115	95,590	3.00
SM19020TRO	190	230	205.0	215.0	220.0	90,320	41,525	260,715	98,515	3.00
SM20020TRO	200	240	215.0	225.0	230.0	96,315	43,110	278,095	102,855	3.20
SM25020TRO	250	290	265.0	275.0	280.0	118,430	48,465	341,850	118,030	4.20
SM30020TRO	300	340	315.0	325.0	330.0	138,490	52,870	399,785	131,010	4.60
SM32020TRO	320	360	335.0	345.0	350.0	148,535	55,040	428,765	137,295	4.84
SM34020TRO	340	380	355.0	365.0	370.0	156,560	56,665	451,930	142,170	5.08
SM36020TRO	360	400	375.0	385.0	390.0	166,570	58,730	480,880	148,210	5.40

Brass; circular pocket pocket separator standard 3/8" balls

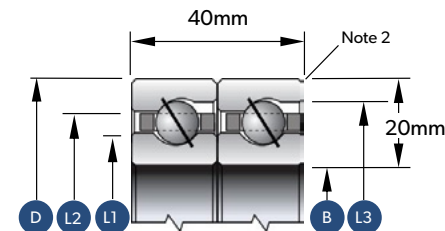

1. Load capacities are not additive
2. The maximum shaft or housing fillet radius that the bearing corners will clear for this series is 1.5mm
3. Race Width Tolerance: +0.000 -0.254mm

Integral Bearing Closures – Seals and Shields

Sometimes it is desirable to have closures on bearings to either prevent or limit contamination from entering the bearing, or lubricant exiting the bearing. For this reason, Silverthin has several standard series of sealed bearings, cross sections JSHA, JSA, JSB and JSU. Other series of Silverthin Thin Section Bearings can also be sealed or shielded, please contact Silverthin Engineering for details.

Seals (Traditional)

Seals are typically a metal backed, molded Buna-N rubber contact seal. In this case the seal lip makes contact with its land-riding surface and makes a positive sealing contact. This type of seal will provide the most effective sealing. The contact pressure can often be reduced or increased if more aggressive sealing or lower torque is desired. Bearings with seals are typically sealed for life, and cannot be relubricated in service. Other materials such as viton or other desirable materials can be used as well. For special application considerations such as high temperatures, chemical exposure, etc. Please contact Silverthin Engineering for details. The graphic below shows a typical cross section using positive-contact seals.

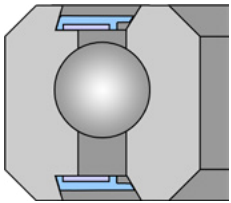

PTFE Coated Tape Seal

This unique sealing solution uses a fiberglass reinforced, PTFE coated sheet material where the sheet is cut, yielding a 'tape seal' to the appropriate inner and outer diameter for insertion into specially machined grooves in the inner and outer ring shoulders of the bearing. This seal provides very low frictional resistance (torque), while providing an effective sealing solution for the bearing in many cases. Silverthin Engineering should be consulted for effective use of this unique option. This seal effectively 'floats' within the groove, providing a labyrinth-style sealing solution.

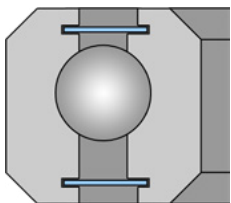

Shields

Shields are a non-contact closure that provide some protection from ingress or egress of contaminants and lubrication, but do not add frictional resistance (torque). Attention to the application and environmental conditions should be paid to ensure that this option is suitable for desired performance results. These are typically manufactured of metal or some other rigid material.

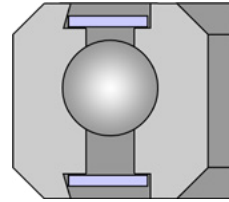

Orientation of Bearings with Closures

Any bearings with closures that are using snapover-type retainers (typically all Type-C and Type-X bearings) are etched with an arrow and the word 'UP' to indicate the recommended mounting orientation. As shown in the diagram below, the arrow should point upward for θ between 0° and 45° . This will help ensure that the retainer rest on the balls, and does not 'hang' from the balls, risking the possibility of the retainer falling from the balls at any time.

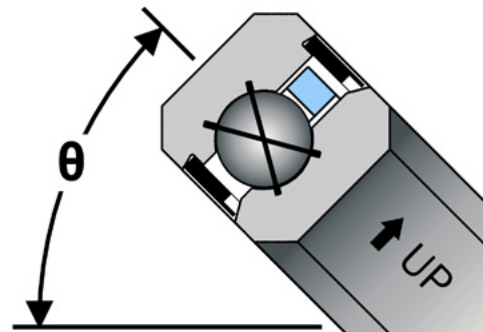

Stainless Steel Bearings (AISI 440C)

Standard base material for Silverthin Thin Section Bearings is the industry standard AISI 52100 Bearing Steel. For applications where the bearing is exposed to corrosive environments Silverthin offers a AISI 440C Stainless Steel as the base material. AISI 440C Stainless Steel offers better resistance to corrosion and is available for each bearing type (Type A, C and X) and both in open and sealed configurations. Overall dimensions and capabilities of AISI 440C Stainless Steel Bearings are identical to those of AISI 52100 Bearing Steel, and same dimension tables can be used for either bearing material. Contact Silverthin Engineering for bearing material recommendations, or for inquiries regarding nonstandard bearing materials.

Other Materials

Depending on the demands of the application, other materials are available. Please consult Silverthin Engineering for bearing material recommendations, or for inquiries regarding nonstandard bearing materials.

Bearing Coatings

Coatings for Silverthin Thin-Section Bearings are available and generally serve one or both of two purposes: corrosion resistance and protection, and lubrication. For a discussion of lubrication, please refer to the Lubrication section of the website and catalog. This section will address corrosion resistance and protection.

Nodular Thin Dense Chrome (NTDC) coating options are available by Silverthin for corrosion resistance whenever 440C Stainless Steel material may not be practical. NTDC coating adheres uniformly to the base metal of a standard Silverthin 52100 Steel bearing via electro-deposited chrome plating and does not chip, crack or peel under severe stress.

NTDC coating offers a uniform coating thickness of approximately 0.0002" and the following characteristics:

- Hardness up to 78 HRC
- Corrosion resistance generally equivalent to 440C Stainless Steel
- FDA Compliance and a blanket food safety approval from the USDA

For torque sensitive applications, NTDC coating may not be advisable, and users should consider using 440C Stainless Steel for corrosion resistance and protection.

While NTDC coating excels in many corrosion sensitive applications, shipboard or coastal salt water or spray exposure, as well as exposure to certain caustic chemicals or gasses, may require special consideration.

Please contact Silverthin Engineering for application review and product suitability.

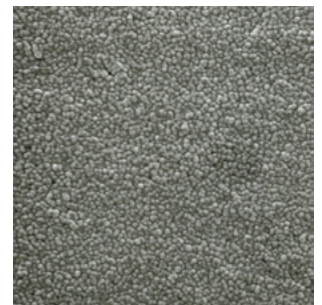
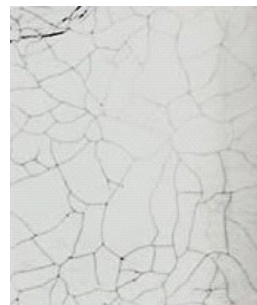

Common Hard Chrome coating (left) is prone to microcracking under stress while NTDC coating (right) microstructure is more resilient to stress.

Hybrid Bearings (Ceramic Balls Si₃N₄)

Silverthin Hybrid Bearings use Ceramic (Silicon Nitride - Si₃N₄) balls to replace traditional AISI 52100 or AISI 440C steel balls. Hybrid bearings typically have reductions in torque, heat generation (greater high speed operation), lubrication requirements and adhesive wear. In many cases lubrication quantity can be reduced while increasing lubrication life.

While Industry Standard catalog Dynamic Load Ratings remain the same for Ceramic and Steel balls, Static Load Ratings must be reduced by approximately 20%. This is because the ceramic ball material is significantly harder than that of a steel ball, and under the same loads will generate a smaller contact footprint and greater contact stress than that of a steel ball. The Silverthin Datasheet Generator discussed on Page 24 will also accept hybrid bearing part numbers and automatically corrects the Static Load Ratings. Add code '-B01' to the end of any Silverthin Datasheet part number to convert it to a hybrid bearing with ceramic balls.

Contact Silverthin Engineering for hybrid bearing application review or recommendations, or for access to the Silverthin Data Generator.



SuperDuplex Thin Section Bearings

If you need a Duplex Pair of Silverthin Thin Section Bearings, you may want to consider a SuperDuplex design.

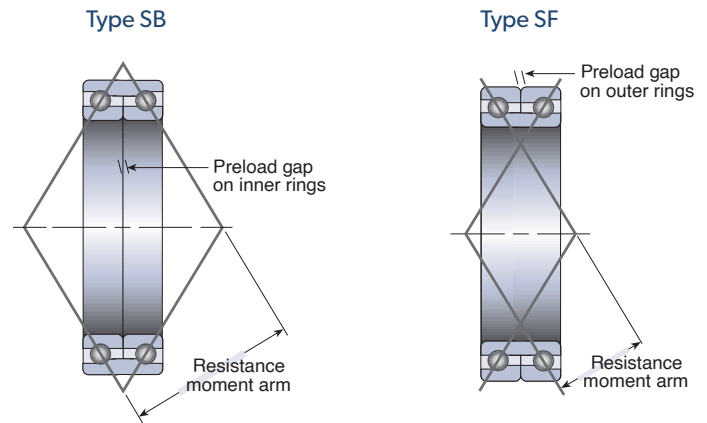

This design provides the exact same technical specifications of a Duplex Pair of Silverthin Type-A (angular contact) bearings, except with a 1-piece outer or inner ring. One of the primary advantages to this design is for ease of assembly into your application. In this case there is no option to space the bearings apart. However, since the two rows of balls share a common outer ring and make up a single assembly, there is no possibility to install the bearing thrust (axial) load orientation improperly. It also may save in assembly time and improved mating component design simplicity. Should greater spacing between the two rows of balls be desired, contact Silverthin Engineering to determine if matched ground spacers from Silverthin are appropriate for your application design and assembly.

Silverthin SuperDuplex Thin Section Bearings come from the factory with your Preload or Clearance specification built in. By clamping the inner rings together, these specifications are achieved.

Refer to the catalog for dimensional tables and part number explanation. It is recommended that Silverthin Engineering be consulted by any designer wanting to use Silverthin SuperDuplex Thin Section bearings.

Custom Bearings or Assemblies

Silverthin is here to translate your specific needs into tangible, high-quality custom solutions.

Why opt for Custom Bearings & Assemblies?

- **Unique Operational Demands:** When off-the-shelf solutions can't meet specialized performance or durability requirements.
- **Space Constraints:** Customized bearings can be designed to fit into spaces with specific dimensions or unusual shapes.
- **Integration with Other Components:** Custom made bearings can be designed to seamlessly integrate with existing systems or assemblies.

Customization

- **For the Aerospace Industry:** We craft bearings that stand up to extreme temperatures, pressures, and vibrations, ensuring resilience in challenging environments.
- **In Medical Equipment:** Precision is paramount. We tailor bearings that align with the meticulous requirements of medical devices and equipment.
- **For Robotics & Automation:** Efficiency and adaptability take center stage. Our custom bearings cater to the dynamic needs of modern automation equipment, ensuring optimal performance.

Our Customization Process

- **Consultation:** A deep dive into your project's requirements, constraints, and desired outcomes.
- **Design & Prototyping:** Crafting initial designs and prototypes for review, ensuring alignment with your vision.
- **Testing & Refinement:** Rigorous tests to validate performance, with iterative refinement based on feedback.
- **Production & Delivery:** Once perfected, your custom bearings or assemblies are produced and delivered, ready to make a positive impact in your equipment.

Contact our Engineers

Let us know about your specific your custom bearing or assembly requirements, and one of our engineers will be happy to review your needs and help you find the product that will best fit your specific application requirements.



Engineering Support

At Silverthin, our goal is to be your complete source for bearing-related engineered solutions to all of your critical application needs. Using the Silverthin Flexible Manufacturing Method, we have the capability and experience to review and analyze your requirements and work with you to develop and optimize bearing needs. While many of these solutions are based at least in part on standard dimensional designs shown in this catalog, Silverthin also provides custom engineered and higher-level assembled solutions and services.

If you are working on an application, contact Silverthin Engineering now for guidance and support at the earliest stage of your efforts.

Common Engineering Support Requests

- Bearing Failure Analysis and Recommendations
- Lubrication Analysis and Recommendations
- Solid modeling and models
- Drawing and Datasheet Generation
- ISO Class 6 Clean Room cleaning, assembly and packaging
- Varied and specialty cages, toroids and slug designs and materials (brass, nylon, phenolic, PEEK, Vespel, stainless steel, etc)
- Varied and specialty seal, shield designs and materials (BunaN, PTFE, Viton, etc)
- Ring base materials of AISI 52100, AISI 440C, Cronidur, 17-4PH, M50 and others
- Rolling element materials of 52100, 440C, Ceramic, 17-4PH, M50 and others
- Special grinding and duplexing, heat treatment / heat stabilization, hardness
- Solid coatings for corrosion resistance as well as lubrication
- Complete Application Review

Complete Design Services:

- Tolerances and Runouts
- Custom diameters and widths
- Special features such as gears or mounting holes
- Mating components and assemblies
- Thin-walled parts
- Special lubricants for all application needs
- Vacuum Impregnation and centrifuge
- Specialty packaging
- Standard and special preload and clearance specifications
- Torque testing including max torque and torque variations
- Custom inner geometries such as conformity, ball path depth, surface finish
- Bearing Life Optimization
- Shaft and housing fit evaluation and recommendations
- Assembly method evaluation and recommendations
- Space Heritage experience

Technical and Analytical Information:

- Estimated bearing torque
- Application Evaluation at wide or extreme temperature ranges
- Bearing Thermal Resistance and Conductivity
- Static and Dynamic Life
- Deflection and Stiffness
- Multiple bearings and bearing type evaluation and analysis
- Impact of changing parameters
- Ball Gapping
- Contact stress evaluation
- Contact ellipse size and truncation evaluation
- Extreme environment evaluation such as Space, Vacuum, Corrosive, Chemical Exposure, Extreme or Varied Temperatures, High Speed, Dithering Motion
- Shaft and Housing Fit Analysis and impact of performance such as Life and Torque

Capacities and Static Safety Factor Calculations

Published Dynamic Capacities

Published Dynamic Capacities are defined as the radial load that when applied to any group of similar bearings will yield one million revolutions of fatigue life for 90% of those bearings. It is important to note that the Dynamic Capacities are not a limitation for applied loads in any manner, but rather should be used solely to estimate expected life of the bearing. They are usually associated with bearings under rotation. For most radial ball bearings these capacities refer only to an Equivalent Radial Load. For Silverthin Thin Section Ball Bearings, all Type-C bearings show only radial capacities. Type-A and Type-X also show thrust capacities. Duplex Type-A and Type-X also show moment capacities. These non-radial capacities are merely a recommendation of loading conditions not to exceed.

Dynamic Life – Published Capacity Approach

The calculation is performed using the following formulas:

$$L_{10} = \left(\frac{C}{P} \right)^3$$

Where:
 L_{10} = Millions of revolutions
 C = Silverthin Dynamic Radial Capacity
 P = Equivalent Radial Load (Effective)

Or, expressed in hours as:

$$L_{10h} = \left(\frac{1,667}{n} \right) \times \left(\frac{C}{P} \right)^3$$

Where:
 L_{10h} = Expected Life in Hours
 n = Rotational Speed in RPM
 C = Silverthin Dynamic Radial Capacity
 P = Equivalent Radial Load (Effective)

For cases with multiple loading conditions (radial, thrust, moment), please consult Silverthin Engineering for additional analysis.

Dynamic Life – Analytical Approach (ISO 16281:2008)

This analytical approach to determining dynamic bearing life looks at the actual contact stress between the rolling elements and the raceways, and considers actual internal geometries which are incorrectly assumed in the Published Capacity Approach. It also considers combined loading conditions (radial, axial, moment), bearing internal fit (clearance or preload), lubrication and lubricant cleanliness, mating components, all materials, temperatures, etc). This methodology will also better determine the Static Safety Factor for the bearings (discussed below) This is a more accurate approach than the Published Capacity Approach noted above. For the Analytical approach, nomenclature for Life is expressed as L10r (millions of revolutions) or L10rh (hours).

Published Static Capacities

Published Static Capacities are defined as “The radial load that when applied to any bearing will yield a permanent deformation (dent) equivalent to 1/10,000th of the diameter of the rolling element”. They are usually associated with (a/the) bearing not rotating, rotating slowly, or making small, intermittent motions. In this case the other capacities mentioned in the section above (thrust and moment) will yield the same contact stress as the definition for static capacity above.

Static Capacity and Static Safety Factor

Published Capacity Approach

The calculation is performed using the following formula:

$$S_0 = \left(\frac{C_0}{P_0} \right)^3$$

Where:
 S_0 = Static Safety Factor
 C_0 = Silverthin Static Capacity
 P_0 = Equivalent Static Load (Effective)

For cases with multiple loading conditions (radial, thrust, moment), please consult Silverthin Engineering for additional analysis.

Static Capacity and Static Safety Factor

Analytical Approach (ISO 10657:1991)

This analytical approach to determining the Static Safety Factor looks at the actual contact stress between the rolling elements and the raceways and considers actual internal geometries which are incorrectly assumed in the Published Capacity Approach. It also considers all loading conditions (radial, axial, moment), bearing internal fit (clearance or preload), mating components, all materials, temperatures, etc.). Lubricant and lubricant cleanliness are not considered for this calculation. This is a more accurate approach than the Published Capacity Approach noted above. For the Analytical approach, nomenclature for the Static Safety Factor is expressed as SF.

For detailed analysis using this method, please contact Silverthin Engineering for assistance.

Speeds

Allowable bearing speeds primarily relate to the amount of heat the bearing will generate during operation. The amount of heat generated and retained during operation is dependent on many factors, including but not limited to:

- Rotational speed.
- Applied Loads (radial, thrust, moment, applied preloads by assembly or spring, etc.).
- Internal bearing loads (preload, applied and/or induced by operating/thermal conditions).
- Type of lubrication. Grease, Oil (bath, mist, coating, etc), Solid Lubricant, other.
- Mating component materials (materials dissipate heat at different rates).
- Mating component design (design features dissipate heat at different rates).
- Flow of fluids through bearings and around mating components (air, lubricants, other fluids).
- Environmental conditions/temperatures.

For Thin Section bearings, the traditional recommendation for maximum allowable speeds has been dependent on a relatively complicated set of catalog-based calculations. These are generic recommendations and do not consider many of the factors noted above. However, by contacting Silverthin Engineering, or using the Silverthin Datasheet Generator, you can find these recommendations with results like the following example:

Example: SB040CP0

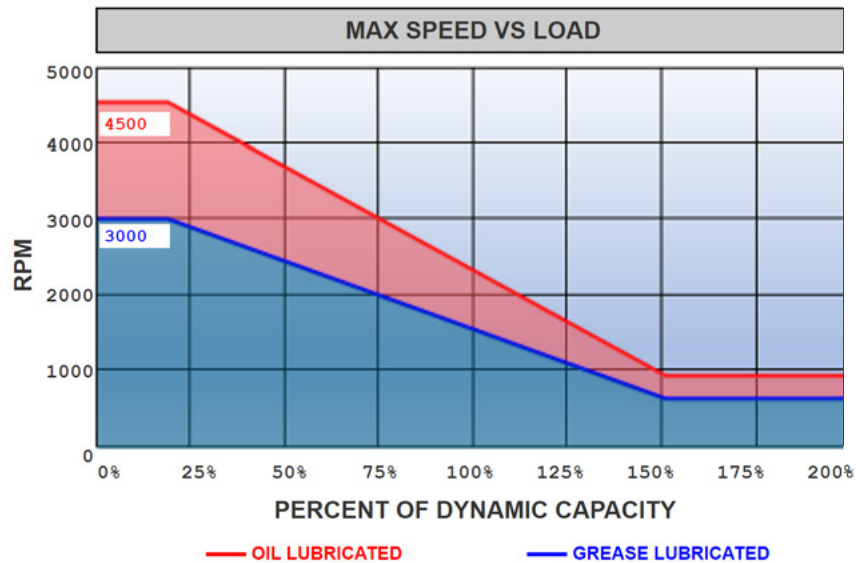

Example: JSB040CP0

(same as SB040CP0 except with 2 seals and grease lubricated for life)

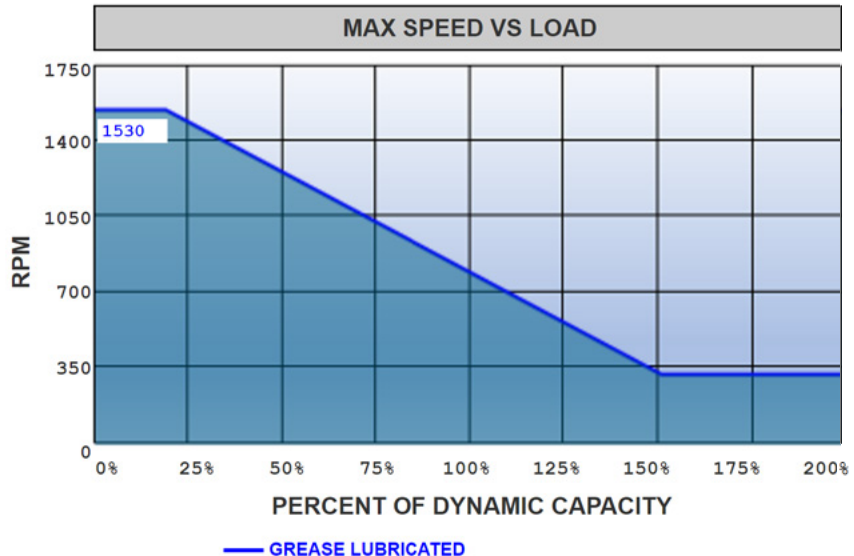

Precision Class and Runout

Precision classifications for Thin Section bearings are governed by ABMA Standard 26.2, with published precision options being ABEC 1F, 3F, 5F and 7F, increasing in precision as the ABEC level increases. Silverthin manufactures bearings as standard to ABEC 1F or greater precision, with all of the other classification available. As the precision classification increases:

- The tolerance range applied to the bearing ID and OD is reduced.
- The maximum runout specification for the Inner and Outer raceways is reduced.

In many applications, higher precision levels for either ID and OD, or for Runouts may be desired. But both may not be necessary. Should only one of these be required, this could improve delivery lead time.

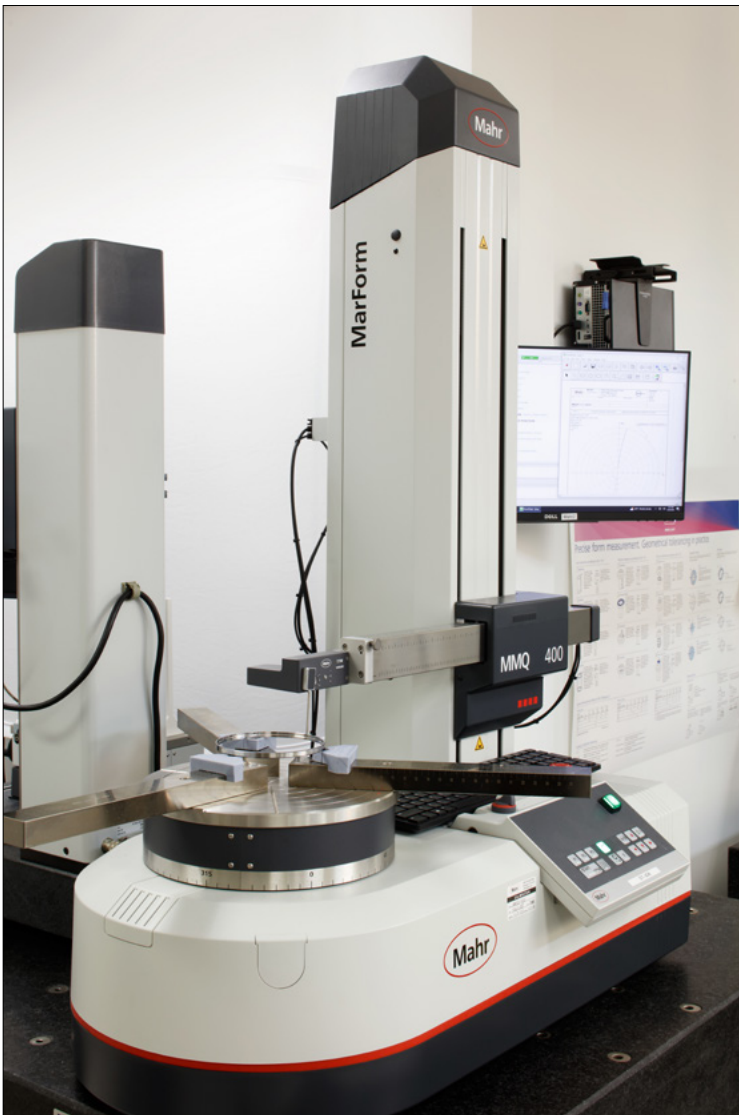



Fits Introductory Statement:

Thin section bearings conform to their mating components and correct tolerancing is both performance critical and application specific. Mating component roundness and flatness should be controlled to half the radial and axial runout tolerance for the bearing selected. The following fit recommendations **should not** be considered for anything other than a starting point, and only valid for shafts & housing of similar materials to the bearing or disparate materials only at stable ambient temperature conditions. Please contact Silverthin Engineering for assistance in selecting shaft and housing fits, especially when:

- Shaft and Housing materials are different than the bearing materials.
- Wide operating temperature ranges are present.
- Bearing rotational torque (friction) is a consideration.

If you are working on an application, contact Silverthin Engineering now for guidance and support at the earliest stage of your efforts.

BEARING SIZE	BEARING DIAMETERS		RADIAL & AXIAL RUNOUT		ROTATING SHAFT OR DUPLEX F MOUNTING		STATIONARY SHAFT OR DUPLEX B MOUNTING				STANDARD BEARING DIAMETRAL CLEARANCE	
	BEARING BORE	BEARING OD	INNER RACE	OUTER RACE	SHAFT DIAMETER	HOUSING BORE	SHAFT DIAMETER		HOUSING BORE		BEFORE INSTALLATION	
	NOMINAL +.0000 (inches)	NOMINAL +.0000 (inches)	RADIAL & AXIAL (inches)	RADIAL & AXIAL (inches)	NOMINAL +.0000 (inches)	NOMINAL +.0000 (inches)	NOMINAL (inches)		NOMINAL (inches)		NOMINAL (inches)	
10	-.0004	-.0005	.0005	.0008	+.0004	+.0005	-.0004	-.0008	-.0005	-.0010	.0010	.0016
15	-.0005	-.0005	.0006	.0008	+.0005	+.0005	-.0005	-.0010	-.0005	-.0010	.0012	.0018
17	-.0006	-.0005	.0008	.0010	+.0006	+.0005	-.0006	-.0012	-.0005	-.0010	.0012	.0024
20	-.0006	-.0005	.0008	.0010	+.0006	+.0005	-.0006	-.0012	-.0005	-.0010	.0012	.0024
25	-.0006	-.0005	.0008	.0010	+.0006	+.0005	-.0006	-.0012	-.0005	-.0010	.0012	.0024
30	-.0006	-.0006	.0008	.0010	+.0006	+.0006	-.0006	-.0012	-.0006	-.0012	.0012	.0024
35	-.0008	-.0006	.0010	.0012	+.0008	+.0006	-.0008	-.0016	-.0006	-.0012	.0016	.0028
40	-.0008	-.0006	.0010	.0012	+.0008	+.0006	-.0008	-.0016	-.0006	-.0012	.0016	.0028
42	-.0008	-.0008	.0010	.0014	+.0008	+.0008	-.0008	-.0016	-.0008	-.0016	.0016	.0028
45	-.0008	-.0008	.0010	.0014	+.0008	+.0008	-.0008	-.0016	-.0008	-.0016	.0016	.0028
47	-.0010	-.0008	.0010	.0014	+.0010	+.0008	-.0010	-.0020	-.0008	-.0016	.0020	.0034
50	-.0010	-.0008	.0012	.0014	+.0010	+.0008	-.0010	-.0020	-.0008	-.0016	.0020	.0034
55	-.0010	-.0010	.0012	.0016	+.0010	+.0010	-.0010	-.0020	-.0010	-.0020	.0020	.0034
60	-.0010	-.0010	.0012	.0016	+.0010	+.0010	-.0010	-.0020	-.0010	-.0020	.0020	.0034
65	-.0010	-.0010	.0012	.0016	+.0010	+.0010	-.0010	-.0020	-.0010	-.0020	.0020	.0034
70	-.0010	-.0012	.0012	.0016	+.0010	+.0012	-.0010	-.0020	-.0012	-.0024	.0020	.0034
75	-.0012	-.0012	.0016	.0018	+.0012	+.0012	-.0012	-.0024	-.0012	-.0024	.0024	.0042
80	-.0012	-.0012	.0016	.0018	+.0012	+.0012	-.0012	-.0024	-.0012	-.0024	.0024	.0042
90	-.0012	-.0012	.0016	.0018	+.0012	+.0012	-.0012	-.0024	-.0012	-.0024	.0024	.0042
100	-.0014	-.0014	.0018	.0020	+.0014	+.0014	-.0014	-.0028	-.0014	-.0028	.0028	.0048
110	-.0014	-.0014	.0018	.0020	+.0014	+.0014	-.0014	-.0028	-.0014	-.0028	.0028	.0048
120	-.0014	-.0014	.0018	.0020	+.0014	+.0014	-.0014	-.0028	-.0014	-.0028	.0028	.0048
140	-.0016	-.0016	.0018	.0020	+.0016	+.0016	-.0016	-.0032	-.0016	-.0032	.0032	.0052
160	-.0018	-.0018	.0018	.0020	+.0018	+.0018	-.0018	-.0036	-.0018	-.0036	.0036	.0056
180	-.0018	-.0018	.0020	.0020	+.0018	+.0018	-.0018	-.0036	-.0018	-.0036	.0036	.0056
200	-.0020	-.0020	.0020	.0020	+.0020	+.0020	-.0020	-.0040	-.0020	-.0040	.0040	.0060
250	-.0030	-.0030	.0020	.0020	+.0030	+.0030	-.0030	-.0060	-.0030	-.0060	.0060	.0080
300	-.0030	-.0030	.0020	.0020	+.0030	+.0030	-.0030	-.0060	-.0030	-.0060	.0060	.0080
350	-.0040	-.0040	.0020	.0020	+.0040	+.0040	-.0040	-.0080	-.0040	-.0080	.0080	.0100

Precision Tolerances & Fits

Inch Series - Type A & X - Precision Class 1 (Ref. ABEC 1F)



BEARING SIZE	BEARING DIAMETERS		RADIAL & AXIAL RUNOUT		ROTATING SHAFT OR DUPLEX F MOUNTING		STATIONARY SHAFT OR DUPLEX B MOUNTING				STANDARD BEARING DIAMETRAL CLEARANCE	
	BEARING BORE	BEARING OD	INNER RACE	OUTER RACE	SHAFT DIAMETER	HOUSING BORE	SHAFT DIAMETER		HOUSING BORE			
	NOMINAL +.0000 (inches)	NOMINAL +.0000 (inches)	RADIAL & AXIAL (inches)	RADIAL & AXIAL (inches)	NOMINAL +.0000 (inches)	NOMINAL +.0000 (inches)	NOMINAL (inches)		NOMINAL (inches)		BEFORE INSTALLATION (inches)	
10	-.0004	-.0005	.0003	.0004	+.0004	+.0005	-.0004	-.0008	-.0005	-.0010	.0010	.0015
15	-.0005	-.0005	.0004	.0004	+.0005	+.0005	-.0005	-.0010	-.0005	-.0010	.0012	.0017
17	-.0006	-.0005	.0005	.0005	+.0006	+.0005	-.0006	-.0012	-.0005	-.0010	.0012	.0022
20	-.0006	-.0005	.0005	.0005	+.0006	+.0005	-.0006	-.0012	-.0005	-.0010	.0012	.0022
25	-.0006	-.0005	.0005	.0005	+.0006	+.0005	-.0006	-.0012	-.0005	-.0010	.0012	.0022
30	-.0006	-.0006	.0006	.0006	+.0006	+.0006	-.0006	-.0012	-.0006	-.0012	.0012	.0022
35	-.0008	-.0006	.0006	.0006	+.0008	+.0006	-.0008	-.0016	-.0006	-.0012	.0016	.0026
40	-.0008	-.0006	.0006	.0006	+.0008	+.0006	-.0008	-.0016	-.0006	-.0012	.0016	.0026
42	-.0008	-.0008	.0008	.0008	+.0008	+.0008	-.0008	-.0016	-.0008	-.0016	.0016	.0026
45	-.0008	-.0008	.0008	.0008	+.0008	+.0008	-.0008	-.0016	-.0008	-.0016	.0016	.0026
47	-.0010	-.0008	.0008	.0008	+.0010	+.0008	-.0010	-.0020	-.0008	-.0016	.0020	.0030
50	-.0010	-.0008	.0008	.0008	+.0010	+.0008	-.0010	-.0020	-.0008	-.0016	.0020	.0030
55	-.0010	-.0010	.0010	.0010	+.0010	+.0010	-.0010	-.0020	-.0010	-.0020	.0020	.0030
60	-.0010	-.0010	.0010	.0010	+.0010	+.0010	-.0010	-.0020	-.0010	-.0020	.0020	.0030
65	-.0010	-.0010	.0010	.0010	+.0010	+.0010	-.0010	-.0020	-.0010	-.0020	.0020	.0030
70	-.0010	-.0012	.0010	.0010	+.0010	+.0012	-.0010	-.0020	-.0012	-.0024	.0020	.0030
75	-.0012	-.0012	.0012	.0012	+.0012	+.0012	-.0012	-.0024	-.0012	-.0024	.0024	.0034
80	-.0012	-.0012	.0012	.0012	+.0012	+.0012	-.0012	-.0024	-.0012	-.0024	.0024	.0034
90	-.0012	-.0012	.0012	.0012	+.0012	+.0012	-.0012	-.0024	-.0012	-.0024	.0024	.0034
100	-.0014	-.0014	.0014	.0014	+.0014	+.0014	-.0014	-.0028	-.0014	-.0028	.0028	.0038
110	-.0014	-.0014	.0014	.0014	+.0014	+.0014	-.0014	-.0028	-.0014	-.0028	.0028	.0038
120	-.0014	-.0014	.0014	.0014	+.0014	+.0014	-.0014	-.0028	-.0014	-.0028	.0028	.0038
140	-.0014	-.0014	.0014	.0014	+.0014	+.0014	-.0014	-.0028	-.0014	-.0028	.0028	.0038
160	-.0016	-.0016	.0016	.0016	+.0016	+.0016	-.0016	-.0032	-.0016	-.0032	.0032	.0042
180	-.0016	-.0016	.0016	.0016	+.0016	+.0016	-.0016	-.0032	-.0016	-.0032	.0032	.0042
200	-.0018	-.0018	.0018	.0018	+.0018	+.0018	-.0018	-.0036	-.0018	-.0036	.0036	.0046
220	-.0018	-.0018	.0018	.0018	+.0018	+.0018	-.0018	-.0036	-.0018	-.0036	.0036	.0046
250	-.0018	-.0018	.0018	.0018	+.0018	+.0018	-.0018	-.0036	-.0018	-.0036	.0036	.0046
300	-.0018	-.0018	.0018	.0018	+.0018	+.0018	-.0018	-.0036	-.0018	-.0036	.0036	.0046
350	-.0020	-.0020	.0020	.0020	+.0020	+.0020	-.0020	-.0040	-.0020	-.0040	.0040	.0050

Precision Tolerances & Fits

Inch Series - Type A, C & X- Precision Class 3 (Ref. ABEC 3F)



BEARING SIZE	BEARING DIAMETERS		RADIAL & AXIAL RUNOUT		ROTATING SHAFT OR DUPLEX F MOUNTING		STATIONARY SHAFT OR DUPLEX B MOUNTING				STANDARD BEARING DIAMETRAL CLEARANCE	
	BEARING BORE	BEARING OD	INNER RACE	OUTER RACE	SHAFT DIAMETER	HOUSING BORE	SHAFT DIAMETER		HOUSING BORE			
	NOMINAL +.0000 (inches)	NOMINAL +.0000 (inches)	RADIAL & AXIAL (inches)	RADIAL & AXIAL (inches)	NOMINAL +.0000 (inches)	NOMINAL +.0000 (inches)	NOMINAL (inches)		NOMINAL (inches)		BEFORE INSTALLATION (inches)	
10	-.0002	-.0003	.0003	.0004	+.0002	+.0003	-.0002	-.0004	-.0003	-.0006	.0007	.0011
15	-.0003	-.0003	.0004	.0004	+.0003	+.0003	-.0003	-.0006	-.0003	-.0006	.0008	.0012
17	-.0004	-.0004	.0004	.0005	+.0004	+.0004	-.0004	-.0008	-.0004	-.0008	.0008	.0018
20	-.0004	-.0004	.0004	.0005	+.0004	+.0004	-.0004	-.0008	-.0004	-.0008	.0008	.0018
25	-.0004	-.0004	.0004	.0005	+.0004	+.0004	-.0004	-.0008	-.0004	-.0008	.0008	.0018
30	-.0004	-.0004	.0004	.0006	+.0004	+.0004	-.0004	-.0008	-.0004	-.0008	.0008	.0018
35	-.0005	-.0004	.0005	.0006	+.0005	+.0004	-.0005	-.0010	-.0004	-.0008	.0010	.0020
40	-.0005	-.0004	.0005	.0006	+.0005	+.0004	-.0005	-.0010	-.0004	-.0008	.0010	.0020
42	-.0005	-.0005	.0005	.0008	+.0005	+.0005	-.0005	-.0010	-.0005	-.0010	.0010	.0020
45	-.0005	-.0005	.0005	.0008	+.0005	+.0005	-.0005	-.0010	-.0005	-.0010	.0010	.0020
47	-.0006	-.0005	.0006	.0008	+.0006	+.0005	-.0006	-.0012	-.0005	-.0010	.0012	.0022
50	-.0006	-.0005	.0006	.0008	+.0006	+.0005	-.0006	-.0012	-.0005	-.0010	.0012	.0022
55	-.0006	-.0006	.0006	.0009	+.0006	+.0006	-.0006	-.0012	-.0006	-.0012	.0012	.0022
60	-.0006	-.0006	.0006	.0009	+.0006	+.0006	-.0006	-.0012	-.0006	-.0012	.0012	.0022
65	-.0006	-.0006	.0006	.0009	+.0006	+.0006	-.0006	-.0012	-.0006	-.0012	.0012	.0022
70	-.0006	-.0007	.0006	.0010	+.0006	+.0007	-.0006	-.0012	-.0007	-.0014	.0014	.0024
75	-.0007	-.0007	.0008	.0010	+.0007	+.0007	-.0007	-.0014	-.0007	-.0014	.0014	.0024
80	-.0007	-.0007	.0008	.0010	+.0007	+.0007	-.0007	-.0014	-.0007	-.0014	.0014	.0024
90	-.0007	-.0007	.0008	.0010	+.0007	+.0007	-.0007	-.0014	-.0007	-.0014	.0014	.0024
100	-.0008	-.0008	.0010	.0012	+.0008	+.0008	-.0008	-.0016	-.0008	-.0016	.0016	.0026
110	-.0008	-.0008	.0010	.0012	+.0008	+.0008	-.0008	-.0016	-.0008	-.0016	.0016	.0026
120	-.0008	-.0009	.0010	.0014	+.0008	+.0009	-.0008	-.0016	-.0009	-.0018	.0018	.0028
140	-.0008	-.0009	.0012	.0014	+.0008	+.0009	-.0008	-.0016	-.0009	-.0018	.0018	.0028
160	-.0009	-.0010	.0014	.0016	+.0009	+.0010	-.0009	-.0018	-.0010	-.0020	.0020	.0030
180	-.0009	-.0010	.0014	.0016	+.0009	+.0010	-.0009	-.0018	-.0010	-.0020	.0020	.0030
200	-.0010	-.0012	.0016	.0018	+.0010	+.0012	-.0010	-.0020	-.0012	-.0024	.0024	.0034

Precision Tolerances & Fits

Inch Series - Type A, C & X - Precision Class 5 (Ref. ABEC 5F)



BEARING SIZE	BEARING DIAMETERS		RADIAL & AXIAL RUNOUT				ROTATING SHAFT OR DUPLEX F MOUNTING		STATIONARY SHAFT OR DUPLEX B MOUNTING				STANDARD BEARING DIAMETRAL CLEARANCE	
	BEARING BORE	BEARING OD	INNER RACE	INNER RACE	OUTER RACE	OUTER RACE	SHAFT DIAMETER	HOUSING BORE	SHAFT DIAMETER	HOUSING BORE	BEFORE INSTALLATION			
	NOMINAL +.0000 (inches)	NOMINAL +.0000 (inches)	RADIAL (inches)	AXIAL (inches)	RADIAL (inches)	AXIAL (inches)	NOMINAL +.0000 (inches)	NOMINAL +.0000 (inches)	NOMINAL (inches)	NOMINAL (inches)	(inches)			
10	-.0002	-.0002	.0002	.0003	.0002	.0003	+.0002	+.0002	-.0002	-.0004	-.0002	-.0004	.0005	.0009
15	-.0002	-.0002	.0002	.0003	.0002	.0003	+.0002	+.0002	-.0002	-.0004	-.0002	-.0004	.0005	.0009
17	-.0003	-.0003	.0002	.0003	.0003	.0004	+.0003	+.0003	-.0003	-.0006	-.0003	-.0006	.0006	.0012
20	-.0003	-.0003	.0002	.0003	.0003	.0004	+.0003	+.0003	-.0003	-.0006	-.0003	-.0006	.0006	.0012
25	-.0003	-.0003	.0002	.0003	.0003	.0004	+.0003	+.0003	-.0003	-.0006	-.0003	-.0006	.0006	.0012
30	-.0003	-.0003	.0002	.0003	.0004	.0005	+.0003	+.0003	-.0003	-.0006	-.0003	-.0006	.0006	.0012
35	-.0003	-.0003	.0003	.0004	.0004	.0005	+.0003	+.0003	-.0003	-.0006	-.0003	-.0006	.0006	.0012
40	-.0003	-.0003	.0003	.0004	.0004	.0005	+.0003	+.0003	-.0003	-.0006	-.0003	-.0006	.0006	.0012
42	-.0003	-.0004	.0003	.0004	.0004	.0005	+.0003	+.0004	-.0003	-.0006	-.0004	-.0008	.0008	.0014
45	-.0003	-.0004	.0003	.0004	.0004	.0005	+.0003	+.0004	-.0003	-.0006	-.0004	-.0008	.0008	.0014
47	-.0004	-.0004	.0003	.0004	.0004	.0005	+.0004	+.0004	-.0004	-.0008	-.0004	-.0008	.0008	.0014
50	-.0004	-.0004	.0003	.0004	.0004	.0005	+.0004	+.0004	-.0004	-.0008	-.0004	-.0008	.0008	.0014
55	-.0004	-.0005	.0003	.0004	.0005	.0006	+.0004	+.0005	-.0004	-.0008	-.0005	-.0010	.0010	.0016
60	-.0004	-.0005	.0003	.0004	.0005	.0006	+.0004	+.0005	-.0004	-.0008	-.0005	-.0010	.0010	.0016
65	-.0004	-.0005	.0003	.0004	.0005	.0006	+.0004	+.0005	-.0004	-.0008	-.0005	-.0010	.0010	.0016
70	-.0004	-.0005	.0003	.0004	.0005	.0006	+.0004	+.0005	-.0004	-.0008	-.0005	-.0010	.0010	.0016
75	-.0005	-.0005	.0004	.0005	.0005	.0006	+.0005	+.0005	-.0005	-.0010	-.0005	-.0010	.0010	.0016
80	-.0005	-.0005	.0004	.0005	.0005	.0006	+.0005	+.0005	-.0005	-.0010	-.0005	-.0010	.0010	.0016
90	-.0005	-.0005	.0004	.0005	.0005	.0006	+.0005	+.0005	-.0005	-.0010	-.0005	-.0010	.0010	.0016
100	-.0005	-.0005	.0005	.0006	.0006	.0007	+.0005	+.0005	-.0005	-.0010	-.0005	-.0010	.0010	.0016
110	-.0005	-.0005	.0005	.0006	.0006	.0007	+.0005	+.0005	-.0005	-.0010	-.0005	-.0010	.0010	.0016
120	-.0005	-.0006	.0005	.0006	.0007	.0008	+.0005	+.0006	-.0005	-.0010	-.0006	-.0012	.0012	.0018
140	-.0006	-.0006	.0005	.0007	.0007	.0008	+.0006	+.0006	-.0006	-.0012	-.0006	-.0012	.0012	.0018
160	-.0006	-.0007	.0007	.0008	.0008	.0009	+.0006	+.0007	-.0006	-.0012	-.0007	-.0014	.0014	.0020
180	-.0006	-.0007	.0007	.0008	.0008	.0009	+.0006	+.0007	-.0006	-.0012	-.0007	-.0014	.0014	.0020
200	-.0007	-.0008	.0008	.0009	.0009	.0010	+.0007	+.0008	-.0006	-.0014	-.0007	-.0016	.0014	.0022

Precision Tolerances & Fits

Metric Series - Type A, C & X- Precision Class 1 (Ref. ABEC 1F)



BEARING SIZE	BEARING DIAMETERS		RADIAL & AXIAL RUNOUT		ROTATING SHAFT OR DUPLEX F MOUNTING		STATIONARY SHAFT OR DUPLEX B MOUNTING				STANDARD BEARING DIAMETRAL CLEARANCE	
	BEARING BORE	BEARING OD	INNER RACE	OUTER RACE	SHAFT DIAMETER	HOUSING BORE	SHAFT DIAMETER		HOUSING BORE			
	NOMINAL +.000 (mm)	NOMINAL +.000 (mm)	RADIAL & AXIAL (mm)	RADIAL & AXIAL (mm)	NOMINAL +.000 (mm)	NOMINAL +.000 (mm)	NOMINAL (mm)		NOMINAL (mm)		BEFORE INSTALLATION (mm)	
20	-.010	-.010	.008	.010	+.010	+.010	-.010	-.020	-.010	-.020	.025	.038
25	-.010	-.010	.008	.010	+.010	+.010	-.010	-.020	-.010	-.020	.025	.038
50	-.012	-.013	.013	.013	+.012	+.013	-.012	-.024	-.013	-.026	.030	.056
60	-.015	-.013	.013	.013	+.015	+.013	-.015	-.030	-.015	-.030	.030	.056
70	-.015	-.015	.015	.015	+.015	+.015	-.015	-.030	-.015	-.030	.030	.056
80	-.015	-.015	.015	.015	+.015	+.015	-.015	-.030	-.015	-.030	.030	.056
90	-.020	-.015	.015	.015	+.020	+.015	-.020	-.040	-.020	-.040	.041	.066
100	-.020	-.015	.015	.015	+.020	+.015	-.020	-.040	-.020	-.040	.041	.066
110	-.020	-.018	.015	.020	+.020	+.018	-.020	-.040	-.020	-.040	.041	.066
120	-.020	-.018	.020	.020	+.020	+.018	-.020	-.036	-.020	-.036	.041	.066
130	-.025	-.018	.025	.025	+.025	+.018	-.025	-.051	-.018	-.036	.051	.076
140	-.025	-.025	.025	.025	+.025	+.025	-.025	-.051	-.025	-.051	.051	.076
150	-.025	-.025	.025	.025	+.025	+.025	-.025	-.051	-.025	-.051	.051	.076
160	-.025	-.025	.025	.025	+.025	+.025	-.025	-.051	-.025	-.051	.051	.076
170	-.025	-.025	.025	.025	+.025	+.025	-.025	-.051	-.025	-.051	.051	.076
180	-.025	-.030	.025	.025	+.025	+.030	-.025	-.051	-.030	-.061	.051	.076
190	-.025	-.030	.025	.025	+.025	+.030	-.025	-.051	-.030	-.061	.051	.076
200	-.030	-.030	.030	.030	+.030	+.030	-.030	-.061	-.030	-.061	.061	.086
250	-.036	-.036	.046	.051	+.036	+.036	-.036	-.071	-.036	-.071	.071	.100
300	-.036	-.036	.046	.051	+.036	+.036	-.036	-.071	-.036	-.071	.071	.100
320	-.036	-.036	.046	.051	+.036	+.036	-.036	-.071	-.036	-.071	.071	.100
340	-.036	-.036	.046	.051	+.036	+.036	-.036	-.071	-.036	-.071	.071	.100
360	-.036	-.036	.046	.051	+.036	+.036	-.036	-.071	-.036	-.071	.071	.100

Precision Tolerances & Fits

Metric Series - Extra Thin Type A, C & X- Precision Class 1 (Ref. ABEC 1F)



BEARING SIZE	BEARING DIAMETERS		RADIAL & AXIAL RUNOUT		ROTATING SHAFT OR DUPLEX F MOUNTING		STATIONARY SHAFT OR DUPLEX B MOUNTING				STANDARD BEARING DIAMETRAL CLEARANCE	
	BEARING BORE	BEARING OD	INNER RACE	OUTER RACE	SHAFT DIAMETER	HOUSING BORE	SHAFT DIAMETER		HOUSING BORE			
	NOMINAL +.000 (mm)	NOMINAL +.000 (mm)	RADIAL & AXIAL (mm)	RADIAL & AXIAL (mm)	NOMINAL +.000 (mm)	NOMINAL +.000 (mm)	NOMINAL (mm)		NOMINAL (mm)		BEFORE INSTALLATION (mm)	
35	-.013	-.013	.010	.010	+.013	+.013	+0.000	-.013	+0.000	-.013	.030	.046
60	-.013	-.013	.013	.013	+.013	+.013	+0.000	-.013	+0.000	-.013	.030	.046
70	-.013	-.013	.015	.015	+.013	+.013	+0.000	-.013	+0.000	-.013	.030	.046
74	-.013	-.013	.015	.015	+.013	+.013	+0.000	-.013	+0.000	-.013	.030	.046
80	-.013	-.013	.015	.015	+.013	+.013	+0.000	-.013	+0.000	-.013	.030	.046
90	-.013	-.013	.015	.015	+.013	+.013	+0.000	-.013	+0.000	-.013	.030	.046
100	-.013	-.013	.015	.015	+.013	+.013	+0.000	-.013	+0.000	-.013	.030	.046

Clearance – Axial vs Radial

Radial and Axial Clearance share a relationship dependent on bearing type. This relationship will be constant within each raceway geometry offering for each series. Axial Clearances for Type C bearings are much greater than that of a same-sized Type X bearing.

See the graphs below which illustrate the relationship between radial and axial clearances by cross section. Please contact Silverthin Engineering for any needed calculations related to your application and design needs.

C-Type Radial vs Axial Clearance by Series¹

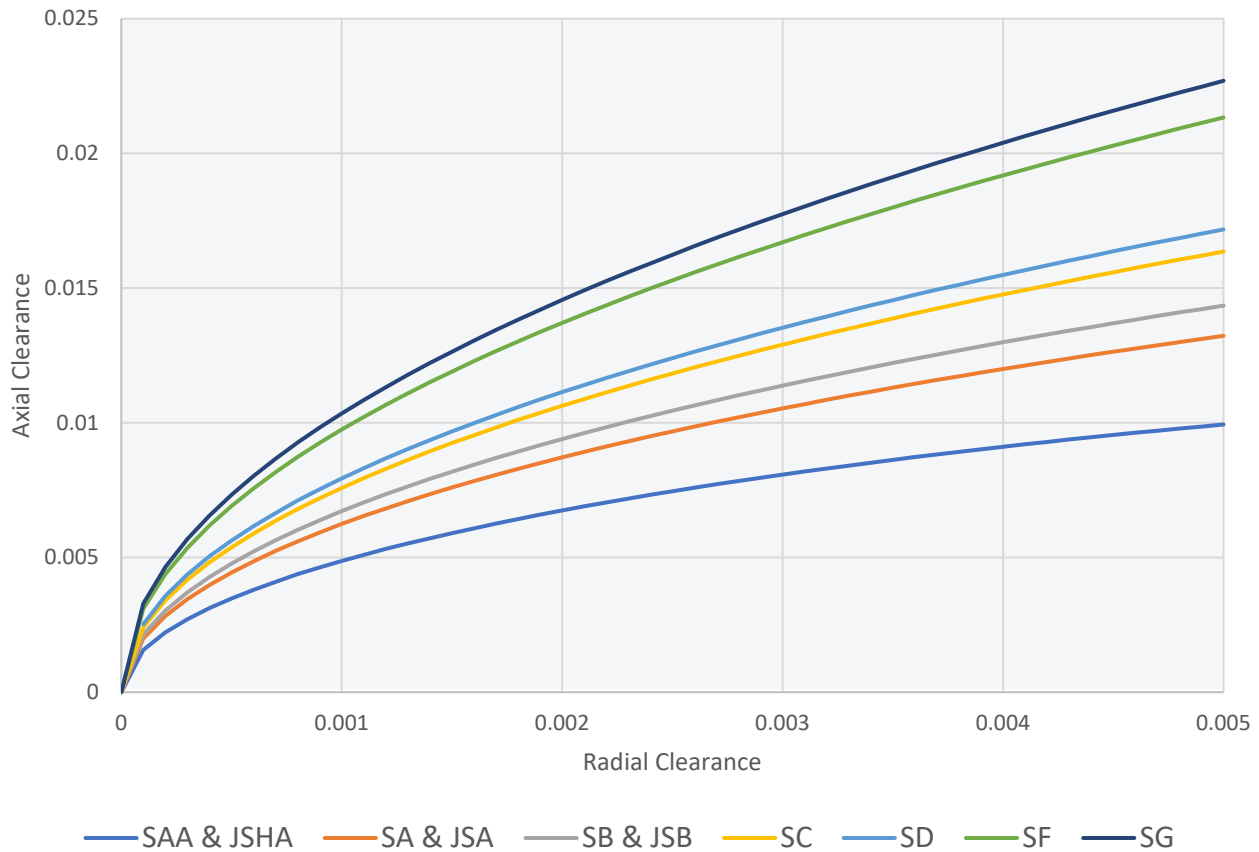

¹ Angular contact bearings have this same relationship, but it is generally only a reference as performance of an angular contact bearing is driven by the desired contact angle.



X-Type Radial vs Axial Clearance by Series

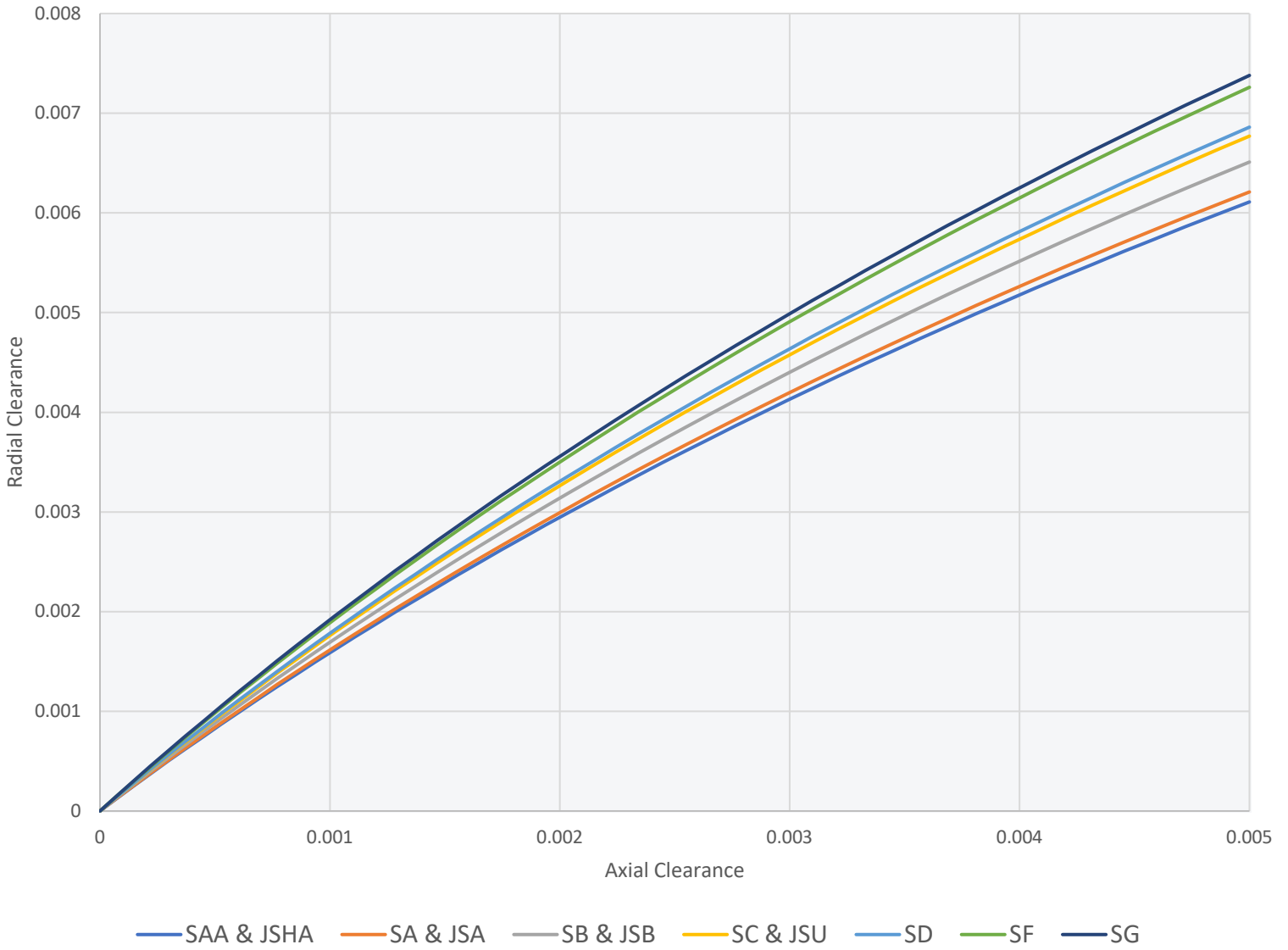



Internal Fits Introductory Statement:

Internal Fit selection is an important part of ensuring proper bearing performance. All Type C and Type X bearings come with a relatively large range of Internal Radial Clearance as Standard unless specified otherwise. This means that there will be free relative movement between the inner and outer rings in the radial, axial and moment directions. Other Internal Radial Clearance and Preload (negative clearance) values can be specified. Either as noted in the table below, or as a special range. Type A bearings can also be pair matched to these same specifications of Clearance or Preload in the axial direction.

For Single Type A bearings, there is no preload or clearance specification and the customer must set those values themselves during their assembly process. However for Duplex Type-A bearings, a preload or clearance specification will be manufactured into the bearings by Silverthin prior to shipment to the customer. Please consult Silverthin Engineering for assistance to identify the optimal specification for your application.

Also note that very light preload values may not be sufficient to properly apply preload to the bearings at assembly, given that a certain minimum preload is necessary to properly seat the balls into the raceways. Failure to impart preload sufficient to seat the balls may result in inadequate application performance such as rough or inconsistent rotation resistance, unanticipated deflections or movement, or other effects.

Internal Fit selection is important when considering:

- Large temperature ranges
- Temperature differences between components
- Dissimilar mating or integral component materials
- Performance such as stiffness, deflection, torque generation

Please contact Silverthin Engineering for assistance in selecting the best internal fit for your application.

Clearance and Preload Part Number Callout

PART NUMBER CALLOUT	INTERNAL FIT TYPE C, X & DUPLXED TYPE A
A	.0000" - .0005" CLEARANCE
B	.0000" - .0010" CLEARANCE
C	.0005" - .0010" CLEARANCE
D	.0005" - .0015" CLEARANCE
E	.0010" - .0020" CLEARANCE
F	.0015" - .0025" CLEARANCE
G	.0020" - .0030" CLEARANCE
H	.0030" - .0040" CLEARANCE
I	.0040" - .0050" CLEARANCE
J	.0050" - .0060" CLEARANCE
K	.0000" - .0005" PRELOAD
L	.0000" - .0010" PRELOAD
M	.0005" - .0010" PRELOAD
N	.0005" - .0015" PRELOAD
P	.0010" - .0020" PRELOAD
Z	SPECIAL

- Diametral Preload or Clearance for Type X or C
- Axial Preload or Clearance for UltraDuplexed Type A

Above internal bearing fits apply to unmounted bearings only. Please contact Silverthin Engineering for installation fits on the above custom clearances and preloads.

Width / Face Flushness Statement:

The width tolerances stated apply to each ring (Inner and Outer) but do not represent Total Bearing Width. For bearings with internal clearance, endplay (axial movement between the inner and outer ring) is impacted by the internal clearance present in each bearing. If the bearing is being used as a locating component or face flushness is otherwise critical, consider a specially ground, or universally ground, bearing. Please contact Silverthin Engineering for assistance.

Minimum Load Requirements

For proper bearing operation, it is necessary to ensure that there is enough load applied to the bearing. This helps to ensure that there is good rotation of the rolling elements, reducing the chance for ball skidding and subsequent heat generation or premature failure. This is especially true for bearings that experience rapid accelerations and decelerations, or operating speeds greater than 50% of the limiting speed for that bearing. This is accomplished either internally by preload, or externally by applied load such as gear loads or the weight of mating components.

A general rule of thumb for ball bearings is that the Minimum Load = $0.01C$ ($0.01 \times$ Dynamic Capacity).

Please contact Silverthing Engineering with any questions.



Duplexing of Silverthin Thin Section Bearings

Silverthin Type A Angular Contact Ball Bearings can be used as single, unmatched bearings. However the overwhelming majority of applications require them to be Duplexed, or Pair Matched (other common terms are Matched Pairs or Matched Sets). The bearing faces are configured in such a way that they can be mounted together to yield a fixed preload or clearance condition. Note that duplexed bearings can consist of more than 2 bearings, such as a Triplex or Quadplex.

The Dynamic Radial Capacity of a set of Duplexed bearings is not as simple as doubling the capacity. Because of load sharing concerns, it is considered that the Dynamic Radial Capacity of two (2) Duplexed bearings is 1.62 times that of a single bearing. For three (3) bearings it is further reduced to 2.16 times that of a single bearing. To simplify, for all bearings of the same specification:

- Single Bearing Radial Dynamic Capacity = C
- Duplex Bearing Radial Dynamic Capacity = C*1.62
- Triplex Bearing Radial Dynamic Capacity = C*2.16

The purpose of Duplexing bearings is to:

- Achieve stiffness, deflection, movement or vibrational performance characteristics.
- Achieve life goals.
- Achieve frictional moment (torque) performance characteristics.
- Accommodate wide and/or extreme temperature ranges.
- Accommodate dissimilar mating component material
- Accommodate reversing thrust and/or moment loading
- Achieve rotational speed goals

Learn more about our SuperDuplex bearings on Page 102.

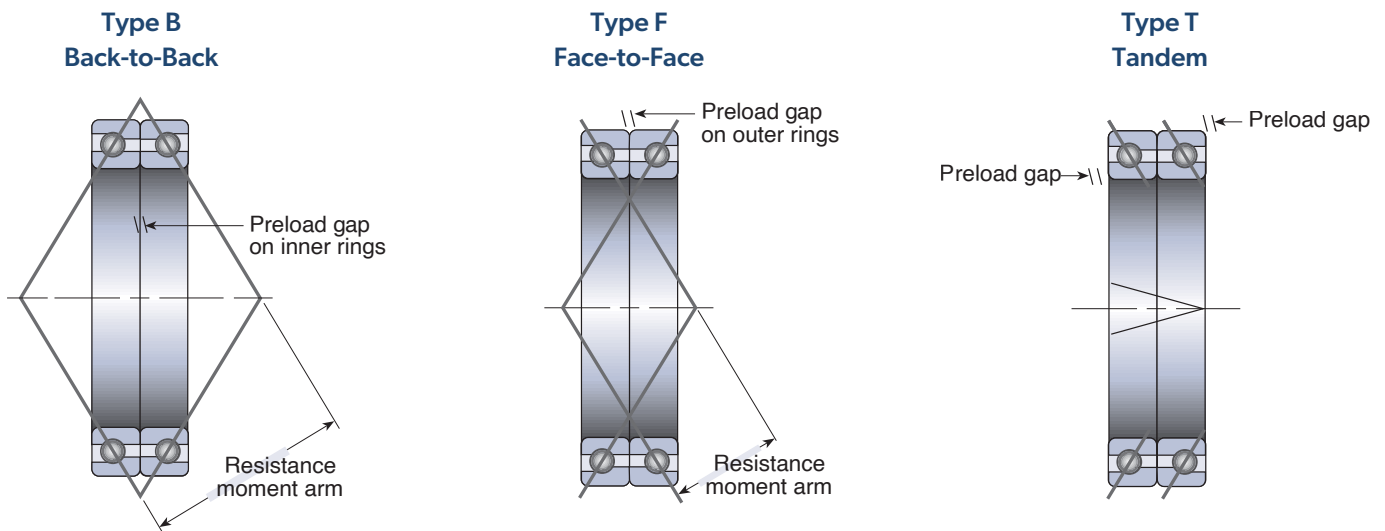

Duplexing of Silverthin Thin Section Bearings - Markings and Orientation

Note that single angular contact ball bearings can only accommodate thrust in one direction. The outer diameter of these bearings is marked with an arrow and the word 'Thrust' to indicate the direction thrust load may be applied. In a Back-to-Back (B) arrangement, these arrows will point away from each other. In a Face-to-Face (F) arrangement, these arrows will point toward each other.

Angular contact bearings purchased as Duplexed Pairs will have a 'V' marking on the OD and ID of the bearing. When the V's are aligned with each other during installation, they are properly oriented. They also represent the location of the high point of radial runout for the duplexed pair. This high point can be aligned with the low point of runout on the mating shaft and housing to reduce overall runout of the assembly.

Correct Orientation

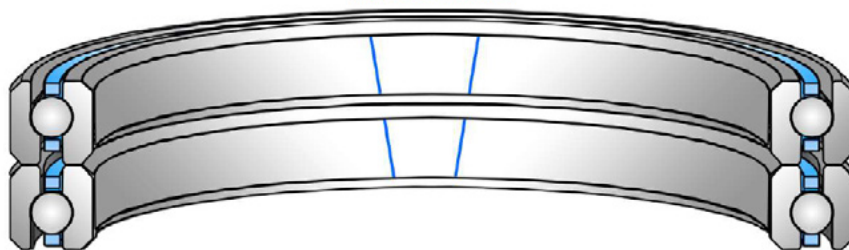

Incorrect Orientation

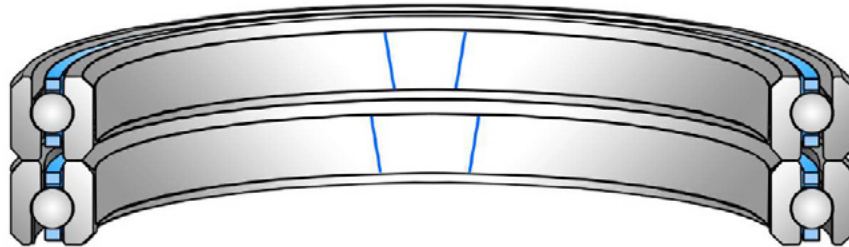



Deflection and Stiffness

As with all bearings, Silverthin Thin Section bearings are subject to the effects of external and internal loads (preload). These performance characteristics are important factors for Designers and Engineers for reasons including:

- Application accuracy
- Movement of components
- Vibration considerations

Deflection is the amount of radial, axial or angular (moment) movement that a bearing will exhibit. If there is clearance in the bearing, the initial amount of loading will consume the clearance, and subsequent loading will deflect the ball and ball path.

Below are typical moment deflection and stiffness curves. In this case for a small duplex pair of Type-A bearings. These curves can also be generated for Radial Load and Axial Load, as well as combined and multiple loading conditions. It is notable that stiffness can sometimes be increased by incorporation of a greater number of small balls.

Silverthin Engineering can provide deflection curves, stiffness curves and a stiffness matrix for each bearing or pair of bearings. Curves will be developed using a range of loads in the axial, radial and moment direction. The stiffness matrix uses specific unchanging loads for each matrix. Separate matrices can be generated for every desired loading condition. These curves are independent of rotational speed.

Contact Silverthin Engineering to request any of these curves for your bearing application, as well as for consultation to provide the best possible solution for your performance requirements.

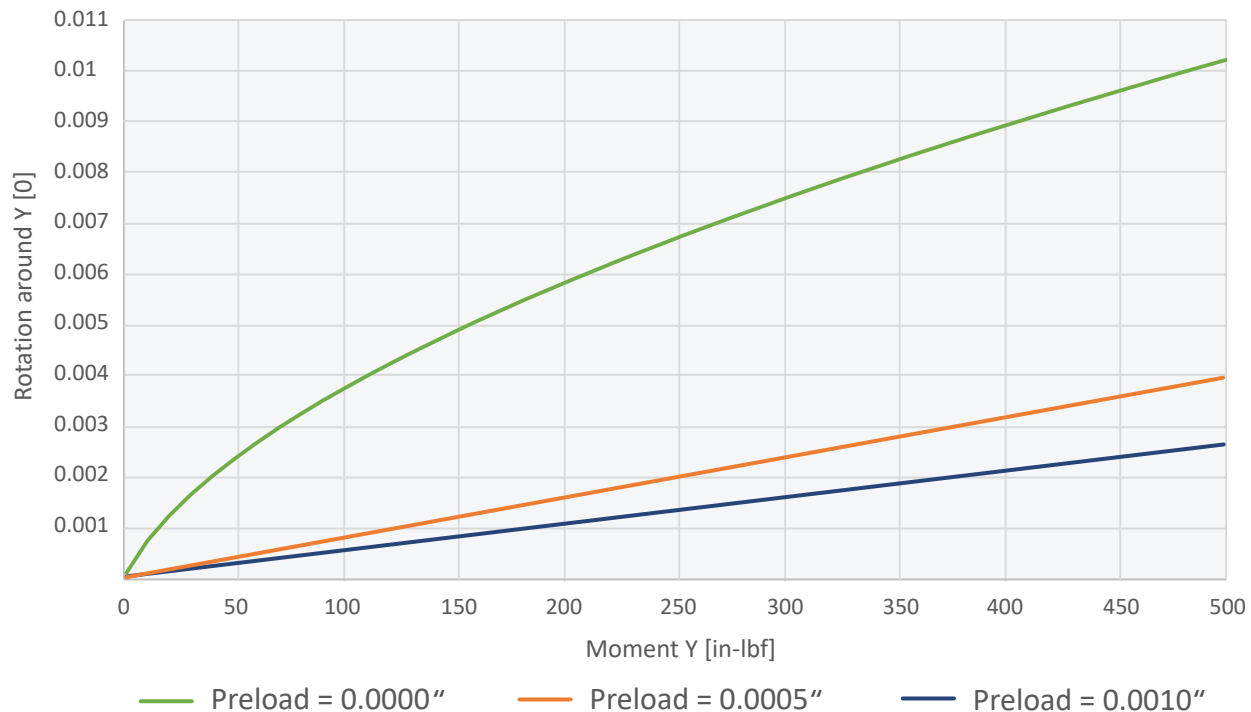

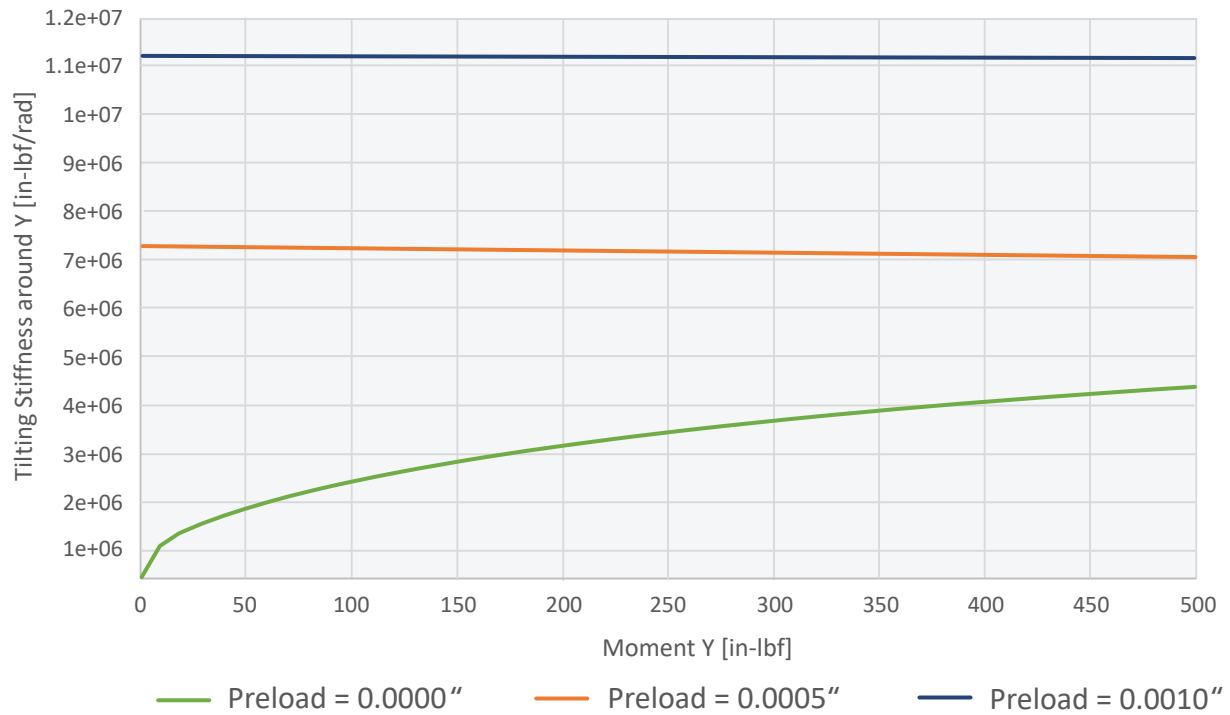

Typical Bearing Stiffness Matrix					
	ux [μin]	uy [μin]	uz [μin]	ry [mrad]	rz [mrad]
FX [LBF]	0.329	-0.583	0.006	113.989	226.192
FY [LBF]	-0.584	1.436	0.004	-152.998	10.589
FZ [LBF]	0.006	0.004	0.592	277.070	152.998
MY [IN-LBF]	0.114	-0.153	0.277	4874.080	-22.877
MZ [IN-LBF]	0.226	0.010	0.153	-22.877	11760.185

Oscillating, Intermittent and Dithering Rotation and Movement

While Silverthin Thin Section Bearings are used in an endless assortment of applications and performance criteria, it is very common to see applications where constant, single-direction movement is either not present or only describes a portion of the performance expectation. This type of rotation and movement presents its own set of considerations such as lubrication, life, loading, contact stress evaluation.

Oscillating, or oscillatory, motion or rotation is the most straightforward to quantify and analyze. In the figure below, the Angle of Oscillation, θ_{osc} , represents the boundaries of the oscillating movement. It is recommended that θ_{osc} be at least 1.5X the ball spacing angle (ψ) to limit the chance for false brinelling. This is commonly referred to as the 'critical angle' ensures that the rolling element contacts override each other.

Intermittent Rotation and Dithering are rotation not necessarily of a constant direction, oscillation angle, or speed, and can involve very small rotations in any direction. All of the variables noted prior can be in a constant state of change or equilibrium.

As stated earlier, for intermittent rotation it is often difficult or impossible to determine an accurate L10 life, therefore other parameters relating to performance are often evaluated, such as:

- Starting Torque ($M_{friction}$). In this case there is typically a maximum allowable torque contributed by the bearings allowed.
- Viscous Torque (M_v). This torque contributor is difficult to calculate with reasonable accuracy, so it is best to determine this value by testing. Certain lubricants are familiar within industries and applications and some generic conclusions as to acceptability can be drawn from experience.
- Static Safety Factor (SF). Typically, it is desirable to have this value be greater than 1.00. A deeper review of contact stress is often helpful in evaluating this parameter.
- Contact Stress (p_{max} , p_{min} , p_{avg}). Many times, contact stress is evaluated to make sure it is not too high.

Contact Silverthin Engineering directly for detailed assistance and recommendations for your application.

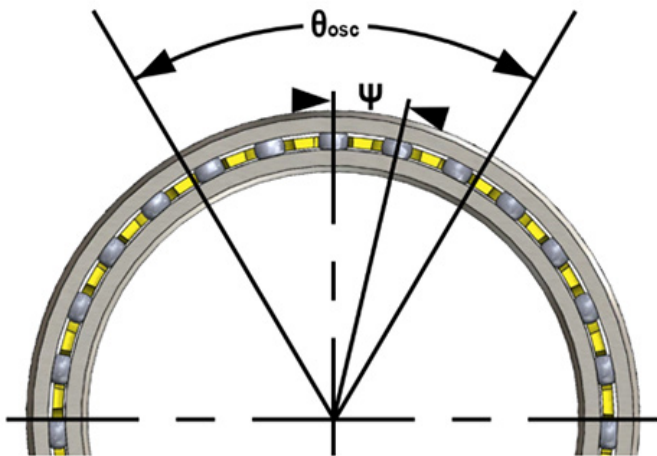

Note that the equivalent speed for oscillation, n_{osc} , can be calculated as follows:

$$n = n_{osc} * \theta_{osc} / 180 \text{degrees}$$

where:

n = Oscillation Speed (rpm)

n_{osc} = Rotational speed over the angle of oscillation

θ_{osc} = Angle of Oscillation

Note: ψ is the angular spacing between balls.

Operating Temperature Range and Mating Components

Temperature range for bearings and their mating components becomes very significant, especially if that range is more than just a few degrees and materials with dissimilar Coefficients of Thermal Expansion (CTE) are used (referred to as 'CTE Mismatch'). The greater the difference between Bearing CTE and Shaft and Housing CTE, the more potentially detrimental the impact on Bearing Preload and Torque. The table below shows CTE examples of common Bearing, Shaft and Housing Materials. Steel Bearings and Aluminum mating components, which are common especially in aerospace applications, can result in the most significant impact to the Bearing, especially at larger diameters:

	in/in-°F	m/m-°C
Steel	6.4×10^{-6}	11.5×10^{-6}
AISI 52100 Steel	6.1×10^{-6}	11.5×10^{-6}
AISI 440C SS	5.6×10^{-6}	10.1×10^{-6}
Aluminum	12.4×10^{-6}	22.3×10^{-6}
Si3N4	1.8×10^{-6}	3.2×10^{-6}
ZrO2	5.7×10^{-6}	10.3×10^{-6}
17-4PH SS	6.0×10^{-6}	10.8×10^{-6}
300 SS	9.6×10^{-6}	17.3×10^{-6}

The larger the dimension, the larger the resultant growth or shrinkage of that dimension due to temperature changes. Larger bearings will experience greater changes than smaller bearings. Additionally, the initial temperature is often the ambient temperature of the environment at assembly of the bearing into the application. This temperature is typically controlled to 68°F (20°C). The final temperature is often the Operating Temperature condition, typically evaluated at the extreme cold and/or extreme hot conditions of the Operating Temperature Range.

The impact of **Shaft and Housing Wall Thickness** becomes more significant as:

- CTE Mismatch becomes larger
- Operating Temperature Ranges become larger

The thinner the Shaft and Housing wall thickness, the less the effect of the shaft expanding the inner ring, and the housing compressing the outer ring, resulting in reduced clearance and possible increased preload. **Increase in preload will result in an increase in Bearing Torque.** An example of the impact of shaft wall thickness is illustrated in the graph below.

The formula for growth or shrinkage of a dimension due to temperature changes is as follows:

$$\Delta \text{ Dimension} = (T_1 - T_2) \times \text{Nominal Dimension} \times \text{CTE}$$

Example of Wall Thickness and CTE Mismatch Effects on Torque
52100 bearing rings and balls with Aluminum Shaft and Housing

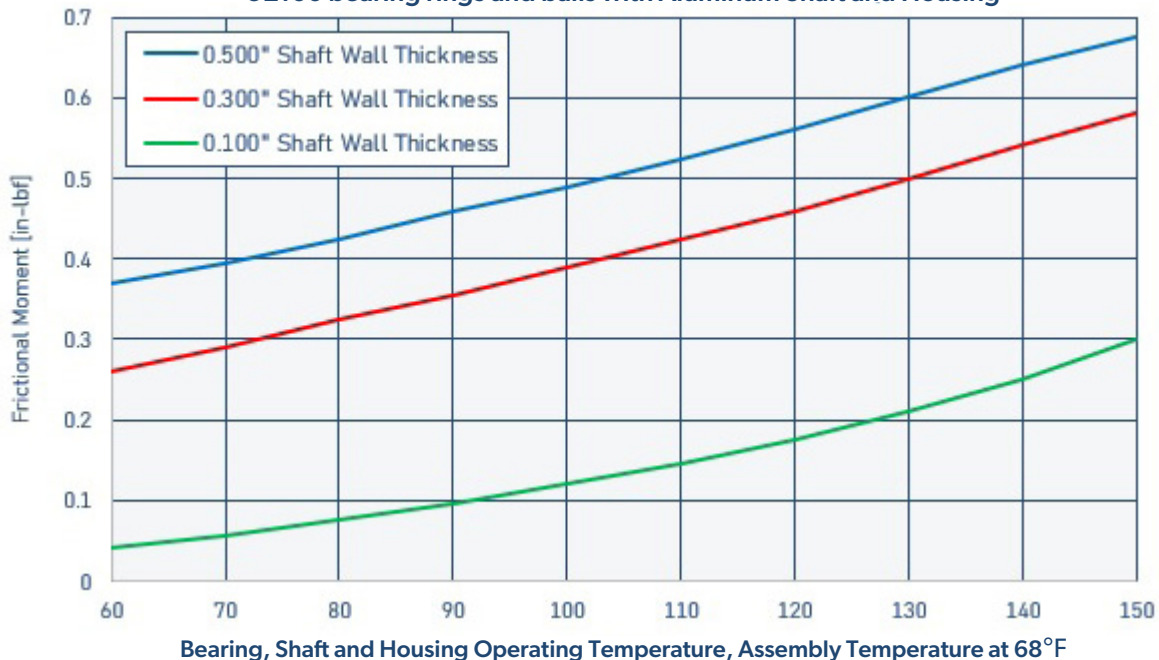

The graph below illustrates how different shaft and housing materials can impact resulting bearing torque over a temperature range from cold to hot. While in this example the shaft and housing wall thicknesses are fixed, you can see from the prior graph that increasing or reducing the wall thicknesses will impact the internal bearing fit, and thus, bearing torque.

CTE Mismatch Effect of Different Materials

52100 Bearing Rings/Balls, 1/4" Thick Shaft and Housing Wall - Torque by Material

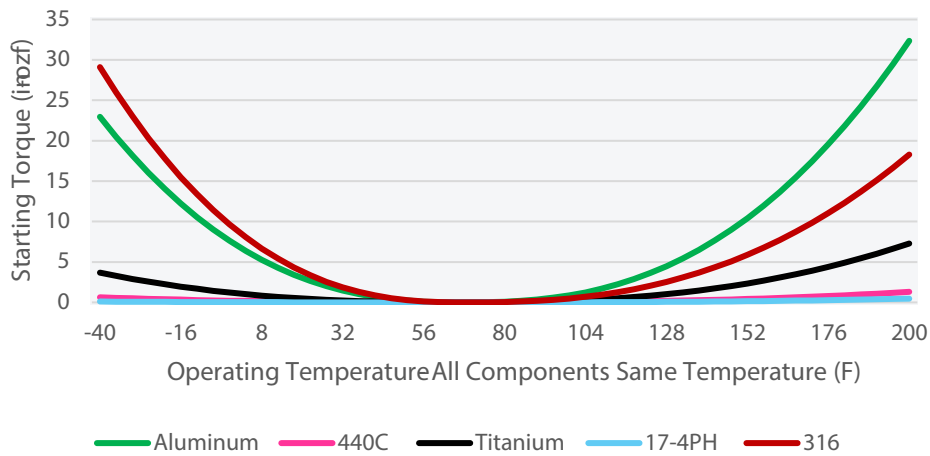

Often, especially in the case of larger bearing diameters, the CTE Mismatch effect on Bearing Torque can be very significant. In such cases it may require additional design considerations to maintain operational preload without exceeding bearing torque limits for a given application. Using sleeves in a manner similar to that shown in Graphic A below, where the sleeve CTE is closer to that of the Bearing Rings, can significantly reduce the CTE Mismatch effect discussed above. By adding sleeves, you can see in Graph B below that the impact of CTE Mismatch is greatly reduced.

Graph B: CTE Mismatch Effect using Sleeves to Reduce

52100 Bearing Rings/Balls, 1/4" Thick Wall Aluminum vs Steel Sleeved Aluminum Shaft and Housing

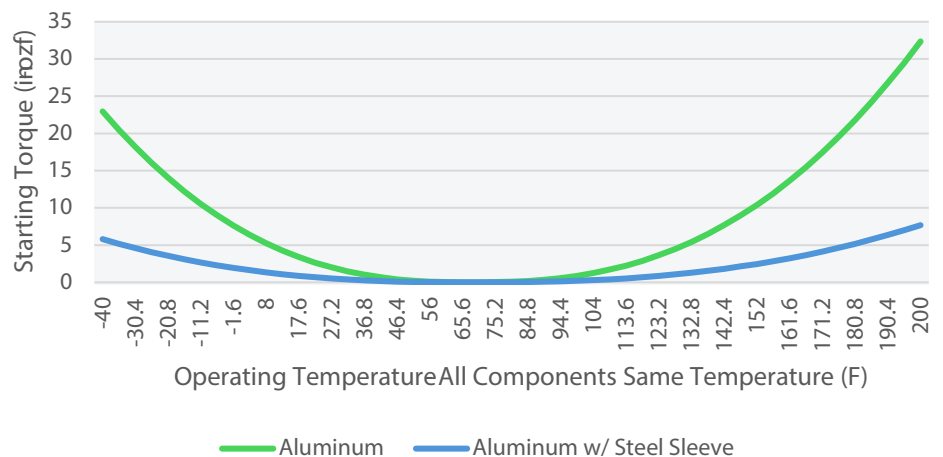
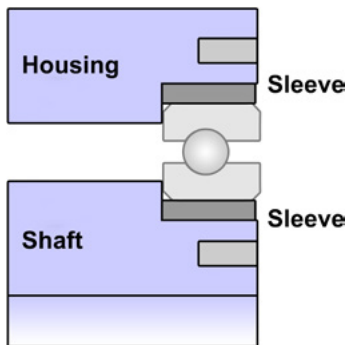

Torque Considerations

Bearing Torque is referred to in many terms including Rotational Resistance and Frictional Moment. This section expands the discussion of torque started in the Rotation and Movement section earlier. The primary drivers of torque in a bearing that Silverthin evaluates are primarily, but not limited to, Load Dependencies. Typically only the loading of the bearing is generally considered in calculations for resulting bearing torque. However, lubrication contribution can be loosely estimated via calculation, but is more accurately understood with testing. This loading can be both external (applied radial, thrust or moment loads to the system) and internal (bearing preload either built-in or induced by application conditions).

Design considerations for torque are as often as follows:

- Bearing Type, Size and Materials
- Operating Temperature Range
- Shaft and Housing (Mating Components) materials
- Shaft and Housing geometry (wall thickness)
- Desired Deflection (movement) of the bearings
- Desired Stiffness of the bearings
- Method of Bearing Installation and Retention
- External Loading
- Internal Loading (preload or clearance)
- Vibration and Impact
- Lubrication Type and Method

Bearing Type and Size are also significant contributors to resulting Bearing Torque. As seen in the diagram below a single Type-C bearing and a duplex pair of Type-A bearings of the same size have relatively similar torque values due to preload. A single Type-X bearing contributes significantly more torque under the same preload. Note that these values below are only for Preload Induced Torque. Any additional external loading will increase the torque values.

The graph below shows a general representation of how torque generation varies by Bearing Type and Cross Section Series. In this case a 10" ID bearing was used.

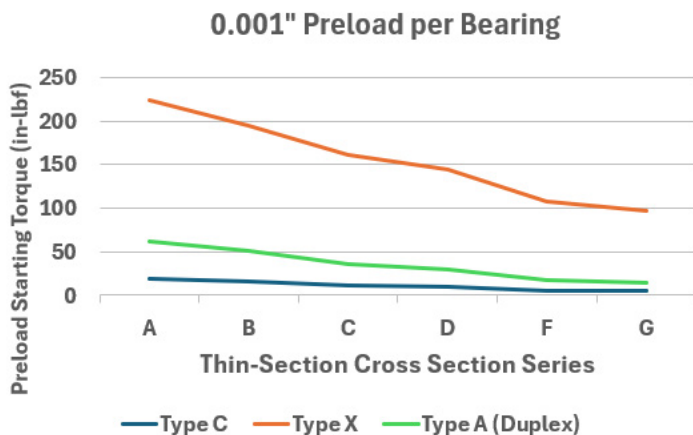

Below is an example of a preload vs torque curve for a Duplex Pair of Type-A bearings. Silverthin Engineering can provide detailed analysis of expected bearing torque for a given preload and provided loading conditions.

Please contact Silverthin Engineering with questions and requests for these technical documents and specifications.

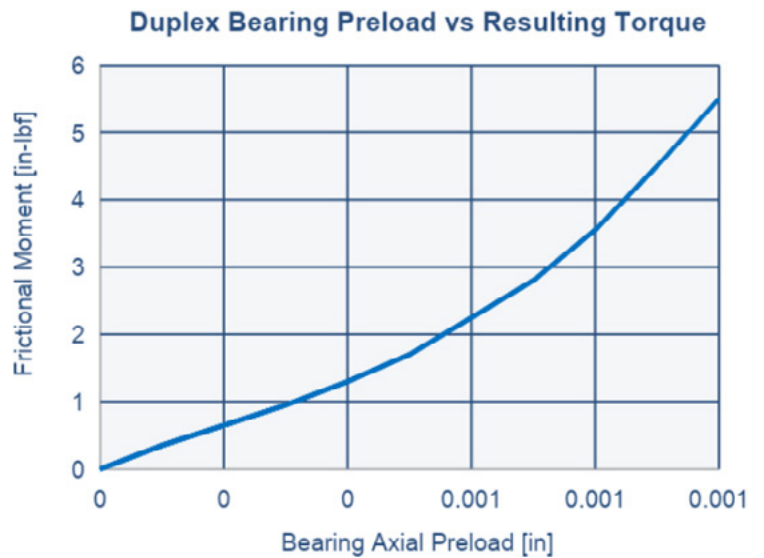

Considerations for the graph above:

- Viscous torque due to lubrication is not calculated.
- Bearings are at room temperature (68°F).
- Typically, not more than 10% of a group of bearings will have torque results greater than those shown for that bearing specification.

Please contact Silverthin Engineering for any needed analysis regarding preload and load effects on resulting torque for bearings suitable for your application as this is a good starting point for applications where low torque requirements are required.

Inspection and Mating Component Design

Silverthin Thin Section bearings are unique for many reasons, and their usage considerations are stricter than standard heavier section bearings. The bearings are designed to save space and weight, and have thinner rings, smaller balls and a greater ball complement compared to bearings of similar diameter. Thin section bearings will be more sensitive to the geometry of mating components as their shape is greatly impacted by their thin design. These bearings will also tend to conform to their mating components, as such it is important that attention is paid to both roundness and flatness of the shaft and housing.

Inspection

Due to the flexibility of thin section bearings, traditional measuring techniques will not yield accurate results. For example, bearing inner and outer diameters cannot be measured with calipers, micrometers or other 2-point measuring methods. In a free state the bearing rings are not perfectly round and must be measured at multiple locations with the values averaged to determine a diameter. Instead, a CMM, air gage, or other multiple position measuring method is required.

This is also true of bearing runout. Runout for Silverthin Thin Section bearings is the deviation of the measurement between the ball path and the inner or outer diameter of the bearing. ABMA 26.2 defines runout of thin section bearings as the raceway to bore or outer diameter thickness variation (radial runout) or the raceway to face parallelism (axial runout).

The graphic below demonstrates the measurement methodology for determining runout for Silverthin Thin Section Bearings.

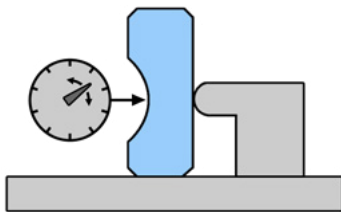

Mating Component Design

Tolerancing of the shaft and housing features are critical for optimal performance of Silverthin Thin Section bearings. This is because the thin nature of the bearing rings will tend to conform to those features. The following recommendations, or better, should be applied to the design:

Flatness Tolerance of the bearing seat that contacts the bearing face should not exceed the bearings Axial Runout specification.

- Flatness \square A for the outer ring housing/outer ring bearing face interface
- Flatness \square B for the inner ring shaft/inner ring bearing face interface

Roundness Tolerance of the bearing seat that contacts the bearing ID or OD should not exceed the bearings Radial Runout specification.

- Roundness \circ C for the outer ring housing ID
- Roundness \circ D for the inner ring shaft ID

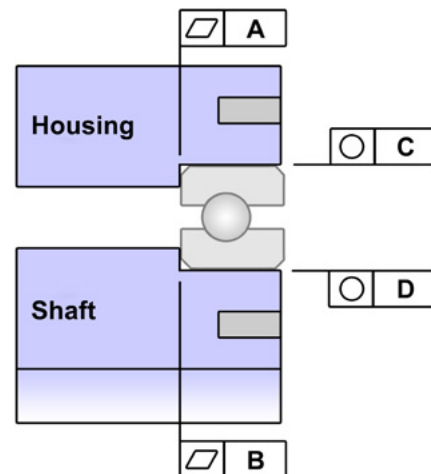

Installation

For interference fits heating and cooling should be used as appropriate to install the bearings onto shafts and into housings. Note that all components should be at room temperature before tightening clamps. If a heating and cooling process is impractical due to the assembly process, bearings may be pressed into the assembly. Press force should only be applied through the bearing ring that is being installed. Installing a bearing inner ring onto a shaft requires pressing bearing inner ring face onto the shaft and installing the bearing outer ring into housing requires pressing bearing outer ring face into the housing.

Clamping of the bearings into place is recommended. Relying solely on a press fit to secure the bearings is insufficient. There should be positive clamping where the face of the ring being clamped protrudes slightly above the clamping face. For even clamping force many fasteners should be used and tightened in a star pattern.

Mounting - Shaft and Housing Interfaces

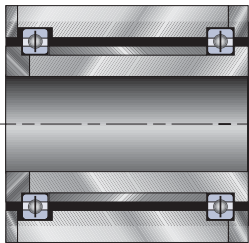

"C" Type radial loading with one floating bearing

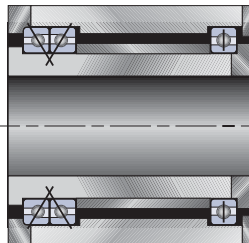

"A" Type "F" pair & floating "C" type mounting

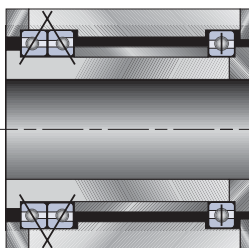

"A" Type "B" pair "C" Type radial thrust floating

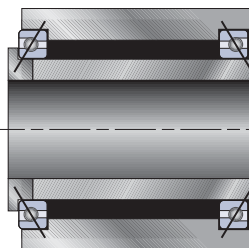

Back-to-Back mounting

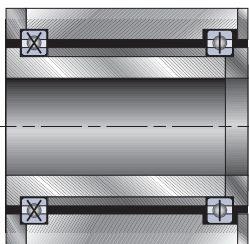

"X" Type & floating "C" Type mounting reversing thrust load & radial loads

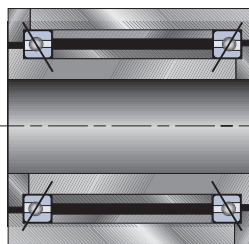

Face-to-Face mounting

Shaft and Housing Fit Recommendations

In the tolerance tables, as well as on the datasheets produced using the Silverthin Datasheet Generator, there are 'standard' recommendations for shaft and housing tolerances which vary depending on bearing type and rotating conditions. Note that these are suggestions, but not firm rules. Additionally, these recommendations are generally for steel shaft and housing materials and standard clearance bearings. For other conditions, please contact Silverthin Engineering for assistance.

There are many factors that often must be considered when selecting appropriate shaft and housing fits, including:

- Assembly method
 - Is a slip fit preferred?
- Disassembly requirements
 - Does the assembly need to be taken apart for future use?
- Bearing torque
 - How will the fits impact bearing torque based on changes to preload or clearance when mounting and during operation?
- Clamping method
 - Is the clamping sufficient to prevent fretting on the shaft or in the housing?
- Overall positioning and rotational accuracy

Bearing lubrication is primarily intended to reduce friction and wear of the bearing, but also serves a variety of other purposes such as heat dissipation and corrosion protection. There are three main categories of lubrication: grease, oil, and dry-film lubricants.

Grease is the appropriate choice of lubricant for most applications. Grease has less tendency for migration which allows for a simpler/lower profile design and often allows bearings to be “lubed for life”. Silverthin sealed bearings are always supplied with grease.

Oil can support much higher bearing speeds, but usually requires a more involved lubrication system. The general rule is that the bearing should not be fully submerged and that the oil level should only reach the midpoint of the lowest rolling element.

Dry-Film Lubricants are typically considered only when environmental considerations prevent grease or oil from being appropriate. Dry-Film Lubricants commonly used include dicronite (WS2), graphite and MoS₂ platings. Dry-Film lubricants have drawbacks of excessive particulate generation and outgassing which may cloud optics or other sensitive components if not taken into consideration.

Selection of the correct lubricant is entirely application driven and should consider the following:

- Desired bearing speeds
- Bearing loads
- Limiting torque development
- Intended service intervals
- Dithering or oscillating rotation
- Environment considerations such as:
 - Temperature extremes
 - Vacuum applications
 - External Radiation
 - Chemical interactions
 - Water washout or miscibility with other liquids

Open Bearings shipped without grease are coated with a MIL-PRF-6085 preservative oil. This is intended to protect Silverthin bearings from corrosion but is not intended for operation. Silverthin recommends that bearings be cleaned and relubricated prior to use.

Sealed Bearings are shipped ready for installation with the external surfaces of the bearing protected using a light layer of the grease used for lubrication. Unless otherwise requested sealed bearings are greased with a 20-30% fill of MIL-G-81322 general purpose grease. Shelf life for sealed bearings is generally 2 years, after which the bearings should be serviced or returned to Silverthin for relubrication.

Silverthin bearings can be shipped with alternative lubricants and custom fill amounts to support your application. In addition to customized bearing lubrication Silverthin on-site assembly processes can control cleanliness and perform other specialized lubrication processed such as:

- Cleaning & relubrication to either refresh or change lubricant
- Processing in a ISO Class 6 clean room environment
- Grease plating
- Vacuum impregnation of ball retainers

Lubricant selection can have a large impact on performance, cost, and lead time. Please contact Silverthin Engineering for lubricant review and product suitability.

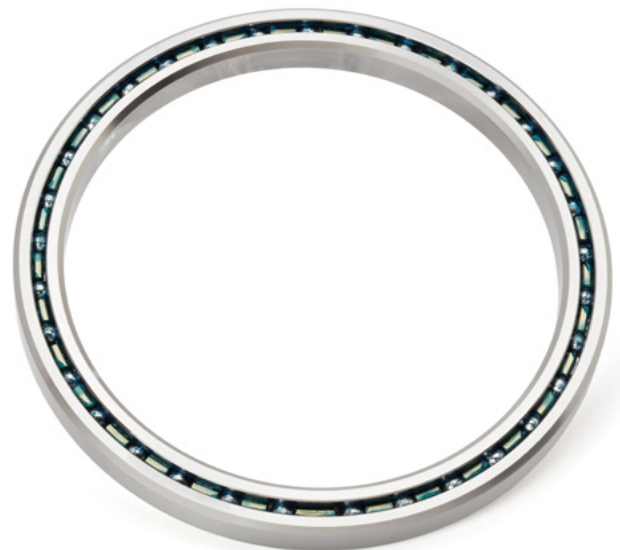

Type C and Type X Bearings, Snapover



- N = Nylon, segmented
- P = Brass
- L = Nylon, one piece
- D = Phenolic, one piece
- T = Stainless steel, one piece



Type A Bearings, Circular Pocket



- R = Brass, one piece
- G = Nylon
- H = Phenolic, one piece
- U = Stainless steel, one piece



- F = Full complement, no retainer, filling slot required for C & X
- S = Spacer Ball, no retainer, filling slot required for C & X

- Z = Other
- ZL = PTFE Slugs (C & X Type Only)
- ZS = Spacer Balls (No Cage)
- ZT = Toroid Spacers (A & Duplex Only)

Note: ZL, ZS and ZT are codes only usable by the Datasheet Generator (Actual Part Number is Z)





At Silverthin, we specialize in catering to unique applications by offering special widths for both thin section bearings and slewing rings as precision shouldn't be a one-size-fits-all solution.

The Significance of Special Widths

- **Unique Operational Needs:** Certain applications demand bearings with non-standard widths to fit seamlessly and deliver optimal performance.
- **Enhanced Load Distribution:** A change in width can influence the bearing's load distribution, potentially improving lifespan and efficiency.
- **Space Constraints:** In tight or uniquely designed spaces, a special width bearing can be the difference between a perfect fit and an operational challenge.

Silverthin's Expertise in Crafting Special Widths

- **Assessment:** We begin by thoroughly understanding your application's demands and the specific challenges associated with it.
- **Design & Craftsmanship:** Our team of experts then crafts bearings with widths tailored to those specifications, ensuring a perfect fit and enhanced performance.
- **Validation:** Each bearing of special or customer specified width is rigorously tested to guarantee it meets both Silverthin's high standards and your operational requirements.
- **Versatility in Application**

Our special width services cater to a wide range of applications:

- **Aerospace:** For equipment where every millimeter of space is accounted for.
- **Medical Instruments:** Where precision and fit can influence patient outcomes.
- **Robotics:** Ensuring seamless integration in automated systems.
- **Heavy Machinery:** Catering to the varying demands of large-scale operations.

At Silverthin, we specialize in catering to special application requirements for:

Space

- **Harsh Space Environments:** Space is a challenging environment with extremes of temperature, radiation, vacuum, and lack of serviceability. Silverthin bearings are engineered to withstand these harsh conditions, providing durability and reliability over the course of a space mission.
- **Reducing Vibration:** Vibrations at launch or in operation negatively impact the performance of spacecraft instruments. Silverthin bearings, with their precise construction and damping properties, help mitigate vibrations, ensuring the stability of sensitive equipment and scientific instruments on board.
- **Customization for Space Applications:** Silverthin bearings can be customized to meet the specific requirements of space missions. This adaptability is essential in the space industry, where each mission may have unique demands based on the intended objectives and environmental conditions.
- **Long-Term Performance:** Space missions often involve extended durations, and the components used must demonstrate long-term performance without the opportunity for maintenance. Silverthin's bearings are designed to provide reliable performance over the lifespan of the mission.

Aerospace

- Silverthin customized bearings range from specialty coatings and lubrications to endure the harsh environment of aerospace and defense.
- Expertise in solving the delicate balance between saving weight and space, limiting torque, providing precise positioning and engineering performance for any mission.

Gimbals

- At Silverthin we bridge the gap between stability, precision, and groundbreaking technology, serving diverse industries that revolve around gimbal technology. In mission-critical applications – from surveillance and security for military and civilian sectors to satellite communications, targeting systems, entertainment lighting, and metrology – we are your cornerstone, offering unparalleled thin section and slewing ring bearing solutions.
- Expertise in solving the delicate balance between saving weight and space, limiting torque, providing precise positioning and engineering performance for any mission.

SLEWING RING OVERVIEW & SELECTION GUIDE

Exemplifying precision and ingenuity, Silverthin Slewing Ring Bearings redefine engineering excellence. Departing from the ordinary, these exceptional components usher in a spectrum of features uniquely tailored to the world of slewing rings. With an unwavering focus on weight reduction, space optimization, and friction minimization, our Slewing Ring Bearings set new standards for efficiency.

Thriving under the most demanding conditions, our Slewing Ring Bearings excel in the face of demanding challenges, consistently surpassing industry expectations. Demonstrating their prowess in industrial equipment, cranes, medical systems, robotics, semiconductors, renewable energy and other demanding applications.

Our Slewing Rings showcase a diverse range of options for your application encompassing various materials, mounting holes configurations, cross-sectional profiles, clearances, special corrosion-resistant coatings, lubricants and more, all highlighting the customizable nature of our products. The pinnacle of our effort is our ability to craft tailored solutions, shaping Slewing Ring Bearings to your exact performance requirements.



Slewing Ring Bearing Types

Rectangular Standard Capacity Slewing Ring - STO & STE Series



Silverthin™ Slewing Ring Bearings are designed to accommodate significant radial, thrust and moment loads with options for non-gear or external gear. rectangular 4-point contact slewing ring offers several benefits due to its design. It provides improved load distribution, higher load-carrying capacity, and enhanced stability compared to other slewing ring configurations.



The four-point contact design allows for higher radial, axial, and moment load capacities while maintaining a relatively compact size. This is accomplished in most cases by the unique four point contact raceway geometry, which is similar in concept to Silverthin™ Type X Thin Section bearings. This type of slewing ring is suitable for applications that require smooth rotation, precise positioning, and the ability to handle heavy loads without sacrificing performance.



STO Non-Gear Series



- Rectangular cross-section
- Four-point contact ball
- Non-gear
- Double Sealed
- Clearance
- Dimensions up to 72" OD



STE External Gear Series

- Rectangular cross-section
- Four-point contact ball
- External gear, AGMA 8 quality minimum
- Double Sealed
- Clearance
- Dimensions up to 72" OD

Rectangular High Capacity Slewing Rings - STO-X & STE-X Series

The Silverthin rectangular high capacity slewing ring boasts several features that make it a versatile choice for various high capacity applications. Its design includes a larger ball diameter and optimized internal structure. This results in higher load-carrying capacity, improved stiffness, and greater durability.



STO-X Non-Gear Series

- Rectangular cross-section
- Four-point contact ball
- Larger ball diameter
- Optimized internal structure
- Non-gear
- Double Sealed
- Clearance
- Dimensions up to 72" OD



STE-X External Gear Series

- Rectangular cross-section
- Four-point contact ball
- Larger ball diameter
- Optimized internal structure
- External gear, AGMA 8 quality minimum
- Double Sealed
- Clearance
- Dimensions up to 72" OD

Flanged Slewing Rings - SK6 Series



The Silverthin SK6 Flanged Slewing Ring Bearings simplify mounting, enhance load distribution, and offer controlled rotation options. The inclusion of gears, whether internal or external, adds the ability to transmit power efficiently, making these designs valuable across a wide range of industries and applications.

Flanged Slewing Ring Bearings come in non-gear, internal gear and external gear configurations that allow a single bearing to accommodate all three loading scenarios moment, thrust and radial. This is accomplished in most cases by the unique four point contact raceway geometry, which is similar in concept to Silverthin™ Type X Thin Section bearings.



Flanged SK6 PZ Non-Gear

- Flanged cross-section
- Four-point contact ball
- Non-gear
- Double Sealed
- Clearance
- Dimensions up to 60" OD

Flanged SK6 NZ Internal Gear

- Flanged cross-section on outer ring
- Four-point contact ball
- Internal gear, AGMA 8 quality minimum
- Double Sealed
- Clearance
- Dimensions up to 60" OD

Flanged SK6 EZ External Gear

- Flanged cross-section on inner ring
- Four-point contact ball
- External gear, AGMA 8 quality minimum
- Double Sealed
- Clearance
- Dimensions up to 60" OD

STE SERIES - External Gear Slewing Ring

Standard Capacity Rectangular Cross Section



STE SERIES EXTERNAL GEAR

- Four-point contact ball
- Rectangular cross section
- External gear, AGMA 8 quality
- Internal clearance
- Dimensions up to 72" OD

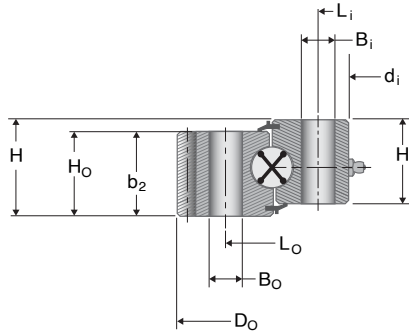

LOAD CONDITION		
MOMENT	THRUST	RADIAL
900,000 ft-lbs to 980,000 ft-lbs	1,150,000 ft-lbs to 1,380,000 ft-lbs	250,000 lbs to 250,000 lbs

SILVERTHIN PART NUMBER	OVERALL DIMENSION (INCH)				APPROX WEIGHT (LBS)	GEAR DATA (A = 20°)					MOUNTING HOLES					MOMENT RATING (FT-LBS)	
	D _o	d _i	H	H _i /H _o		TOOTH FORM	D ₂ (INCH)	GEAR PITCH P _d (INCH)	MAX TOOTH LOAD F ₂ (LBS)	# OF TEETH Z ₂	INNER RING			OUTER RING			
											L _i (INCH)	# HOLES n _i	B _i (INCH)	L _o (INCH)	# HOLES n _o		B _o (INCH)
STE-145	12.286	5.709	1.968	1.732	38	FS	12	5/7	7,140	60	6.890	16	0.562	10.630	16	0.562	18,700
STE-145T	12.286	5.709	1.968	1.732	38	FS	12	5/7	7,140	60	6.890	16	5/8-11	10.630	16	5/8-11	18,700
STE-210	14.686	8.268	1.575	1.496	38	FS	14.4	5/7	5,810	72	9.449	20	0.562	13.190	16	0.562	23,690
STE-210T	14.686	8.268	1.575	1.496	38	FS	14.4	5/7	5,810	72	9.449	20	5/8-11	13.190	16	5/8-11	23,690
STE-265	17.086	10.433	1.968	1.732	57	FS	16.8	5/7	7,330	84	11.614	24	0.562	15.354	18	0.562	40,940
STE-265T	17.086	10.433	1.968	1.732	57	FS	16.8	5/7	7,330	84	11.614	24	5/8-11	15.354	18	5/8-11	40,940
STE-324T	20.486	12.750	2.062	2.022	105	FS	20.2	5/7	8,700	101	14.375	20	5/8-11	18.875	20	5/8-11	62,130
STE-415	24.650	16.250	2.375	2.063	132	SD	24.25	4	10,420	97	17.750	20	0.813	22.250	16	0.813	101,370
STE-415T	24.650	16.250	2.375	2.063	132	SD	24.25	4	10,420	97	17.750	20	3/4-10	22.250	16	3/4-10	101,370
STE-470	26.900	18.500	2.375	2.063	147	SD	26.5	4	10,460	106	20.000	24	0.813	24.500	18	0.813	125,300
STE-470T	26.900	18.500	2.375	2.063	147	SD	26.5	4	10,460	106	20.000	24	3/4-10	24.500	18	3/4-10	125,300
STE-540	29.650	21.250	2.375	2.063	163	SD	29.25	4	10,520	117	22.750	28	0.813	27.250	24	0.813	157,590
STE-540T	29.650	21.250	2.375	2.063	163	SD	29.25	4	10,520	117	22.750	28	3/4-10	27.250	24	3/4-10	157,590
STE-590	33.534	23.125	2.875	2.563	283	SD	33	3	17,290	99	24.875	24	0.938	30.625	18	0.938	213,320
STE-590T	33.534	23.125	2.875	2.563	283	SD	33	3	17,290	99	24.875	24	7/8-9	30.625	18	7/8-9	213,320
STE-705	38.201	27.750	2.875	2.563	325	SD	37.667	3	17,390	113	29.500	28	0.938	35.250	24	0.938	371,940
STE-705T	38.201	27.750	2.875	2.563	325	SD	37.667	3	17,390	113	29.500	28	7/8-9	35.250	24	7/8-9	371,940
STE-730	41.850	28.750	3.250	2.880	491	SD	41.2	2.5	21,290	103	31.000	24	1.063	38.000	20	1.063	468,100
STE-730T	41.850	28.750	3.250	2.880	491	SD	41.2	2.5	21,290	103	31.000	24	8-1	38.000	20	8-1	468,100
STE-870	47.444	34.250	4.250	3.875	771	SD	46.8	2.5	31,620	117	36.250	28	1.188	43.875	24	1.188	920,970
STE-870T	47.444	34.250	4.250	3.875	771	SD	46.8	2.5	31,620	117	36.250	28	11/8-7	43.875	24	11/8-7	920,970



STO SERIES - No Gear Slewing Ring

Standard Capacity Rectangular Cross Section



STO SERIES No Gear Slewing Ring

- Four-point contact ball
- Rectangular cross section
- Non-gear
- Internal clearance
- Dimensions up to 72" OD

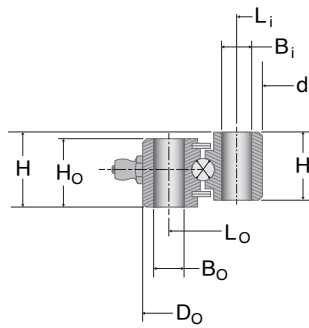

* STO-050 & STO-065 only

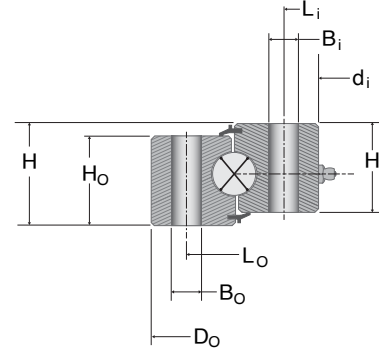

* STO-122 and larger

SILVERTHIN PART NUMBER	OVERALL DIMENSION (INCH)				APPROX WEIGHT (LBS)	MOUNTING HOLES						MOMENT RATING (FT-LBS)
	D _o	d _i	H	H _i /H _o		INNER RING			OUTER RING			
						L _i (INCH)	# HOLES n _i	B _i (INCH)	L _o (INCH)	# HOLES n _o	B _o (INCH)	
STO-050	4.331	1.968	0.787	0.728	2	2.480	8	0.26	3.818	8	0.26	515
STO-050T	4.331	1.968	0.787	0.728	2	2.480	8	M6	3.818	8	M6	515
STO-065	5.315	2.559	0.866	0.787	4	3.149	8	0.354	4.724	8	0.354	910
STO-065T	5.315	2.559	0.866	0.787	4	3.149	8	M8	4.724	8	M8	910
STO-122	8.898	4.803	1.339	1.142	13	5.512	12	0.354	8.189	12	0.354	5,700
STO-122T	8.898	4.803	1.339	1.142	13	5.512	12	M8	8.189	12	M8	5,700
STO-143	9.803	5.630	1.339	1.142	15	6.496	12	0.433	8.937	12	0.433	7,080
STO-143T	11.811	5.709	1.339	1.142	15	6.496	12	M10	8.937	12	M10	7,080
STO-145	11.811	5.709	1.968	1.732	37	6.890	16	0.565	10.630	16	0.565	19,050
STO-145T	12.286	5.709	1.968	1.732	37	6.890	16	5/8-11	10.630	16	5/8-11	19,050
STO-170	12.205	6.693	1.811	1.614	33	7.874	12	0.512	11.024	12	0.512	17,080
STO-170T	14.370	8.268	1.811	1.614	33	7.874	12	M12	11.024	12	M12	17,080
STO-210	14.370	8.268	1.575	1.496	38	9.449	20	0.562	13.190	16	0.562	24,170
STO-210T	14.686	8.268	1.575	1.496	38	9.449	20	5/8-11	13.190	16	5/8-11	24,170
STO-265	16.535	10.433	1.968	1.732	54	11.614	24	0.562	15.354	18	0.562	41,770
STO-265T	17.086	10.433	1.968	1.732	54	11.614	24	5/8-11	15.354	18	5/8-11	41,770
STO-324T	20.486	12.770	2.062	2.022	105	14.375	20	5/8-11	18.875	20	5/8-11	63,390

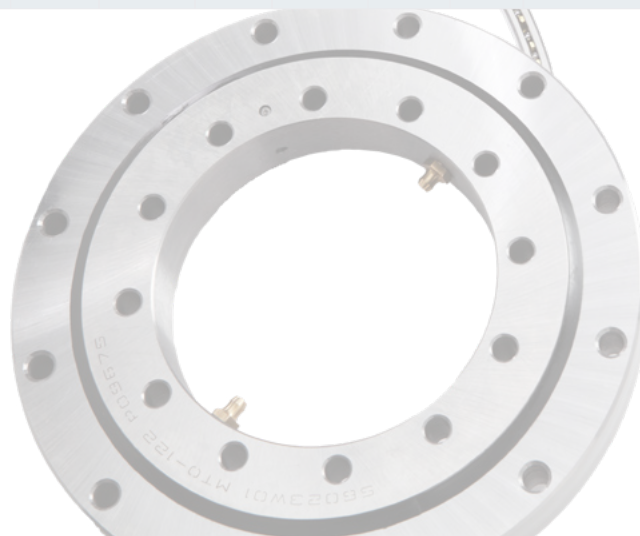

STE-X SERIES - External Gear Slewing Ring

High Capacity Rectangular Cross Section



STE-X HIGH CAPACITY EXTERNAL GEAR

- Four-point contact ball
- Rectangular cross section
- External gear, AGMA 8 quality
- Internal clearance
- Dimensions up to 72" OD

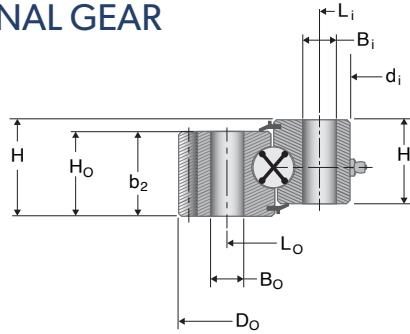

LOAD CONDITION		
MOMENT	THRUST	RADIAL
10,000,000 ft-lbs	6,000,000 lbs	1,300,000 lbs

SILVERTHIN PART NUMBER	OVERALL DIMENSION (INCH)				APPROX WEIGHT (LBS)	GEAR DATA (A = 20°)					MOUNTING HOLES						MOMENT RATING (FT-LBS)
	D _o	d _i	H	H _i /H _o		TOOTH FORM	D ₂ (INCH)	GEAR PITCH P _d (INCH)	MAX TOOTH LOAD F ₂ (LBS)	# OF TEETH Z ₂	INNER RING			OUTER RING			
											L _i (INCH)	# HOLES n _i	B _i (INCH)	L _o (INCH)	# HOLES n _o	B _o (INCH)	
STE-145X	12.286	5.709	1.968	1.732	38	FS	12.0	5/7	7,140	60	6.890	16	0.594	10.630	16	0.594	21,430
STE-210X	14.686	8.268	1.968	1.732	44	FS	14.4	5/7	7,290	72	9.449	20	0.594	13.190	16	0.594	30,720
STE-265X	17.086	10.433	1.968	1.732	57	FS	16.8	5/7	7,330	84	11.614	24	0.594	15.354	18	0.594	47,700
STE-324X	20.486	12.770	2.375	2.063	105	FS	20.2	5/7	8,863	101	14.375	20	0.688	18.875	20	0.688	73,750



STO-X SERIES - No Gear Slewing Ring

High Capacity Rectangular Cross Section



STO-X HIGH CAPACITY NO GEAR

- Four-point contact ball
- Rectangular cross section
- Non-gear
- Internal clearance
- Dimensions up to 72" OD

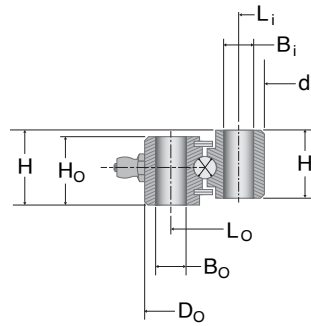

* STO-050 & STO-065 only

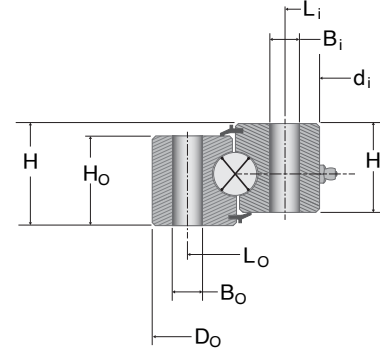

* STO-122 and larger

SILVERTHIN PART NUMBER	OVERALL DIMENSION (INCH)				APPROX WEIGHT (LBS)	MOUNTING HOLES						MOMENT RATING (FT-LBS)
	D _o	d _i	H	H/H _o		INNER RING			OUTER RING			
						L _i (INCH)	# HOLES n _i	B _i (INCH)	L _o (INCH)	# HOLES n _o	B _o (INCH)	
STO-145X	12.205	6.693	1.968	1.732	41	6.890	16	0.594	10.630	16	0.594	21,800
STO-210X	16.535	10.433	1.968	1.732	48	11.614	20	0.594	13.190	16	0.594	31,330
STO-265X	20.486	12.770	1.968	1.732	61	11.614	24	0.594	15.354	18	0.594	48,670
STO-324X	14.686	8.268	2.375	2.063	105	14.375	20	0.688	18.875	20	0.688	75,200

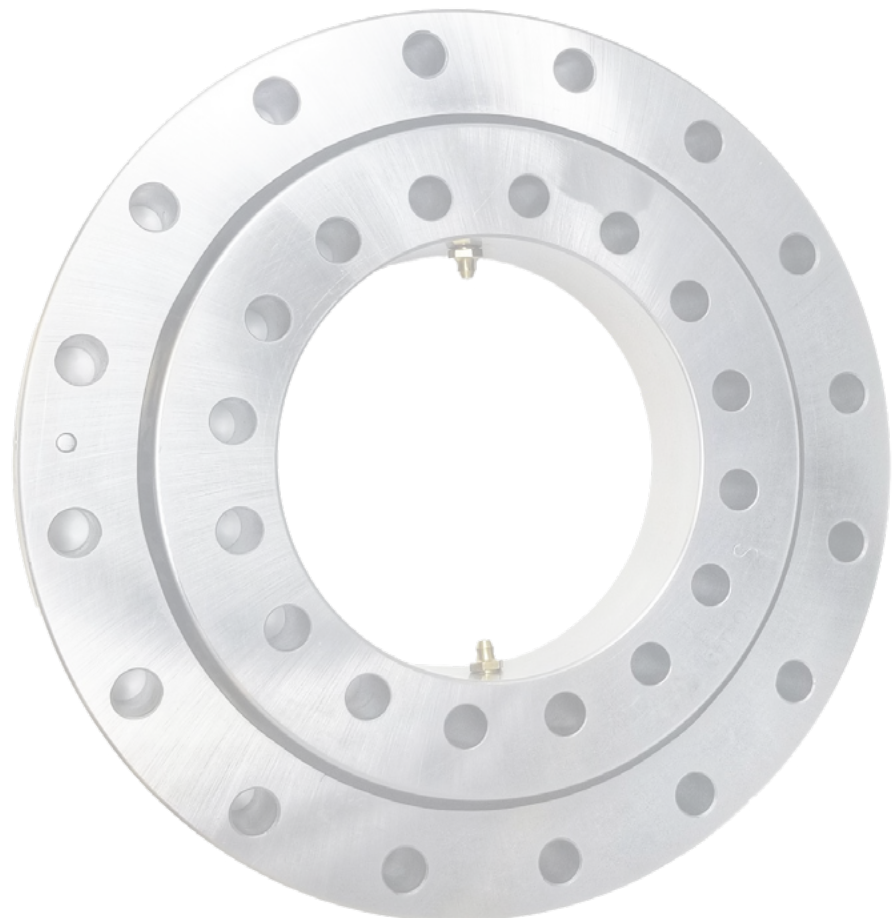

SK6 SERIES - Flanged Slewing Ring

Internal Gear



SK6 NZ - INTERNAL GEAR

- Four-point contact ball
- Flanged cross-section on non-gearred rings
- Internal gear, AGMA 8 quality
- Internal clearance
- Dimensions up to 60" OD

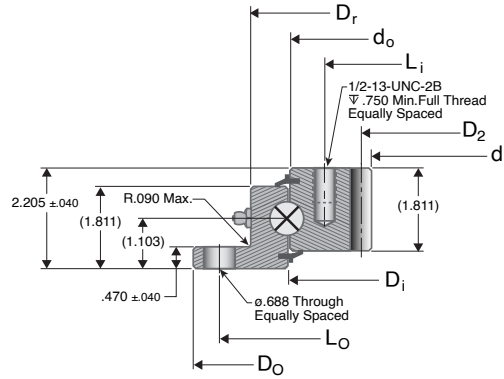

LOAD CONDITION		
MOMENT	THRUST	RADIAL
141,000 ft-lbs to 180,000 ft-lb	175,000 ft-lbs to 223,000 ft-lbs	35,000 lbs to 45,000 lbs

SILVERTHIN PART NUMBER	OVERALL DIMENSION (INCH)						APPROX WEIGHT (LBS)	GEAR DATA (A = 20°)				MOUNTING HOLES				MOMENT RATING (FT-LBS)
	D _o	D _i	D _r	d _i	d _r	d _o		D ₂ (INCH)	GEAR PITCH P _d (INCH)	MAX TOOTH LOAD F ₂ (LBS)	# OF TEETH Z ₂	INNER RING		OUTER RING		
												L _i (INCH)	# HOLES n _i	L _o (INCH)	# HOLES n _o	
SK6-16NZ	20.390	16.339	17.870	12.850	-	16.260	65	13.250	4	6,800	53	14.880	12	19.250	8	23,300
SK6-22NZ	25.510	21.340	22.990	17.600	-	21.260	90	18.000	4	6,530	72	19.630	15	24.380	10	33,630
SK6-25NZ	29.450	25.280	26.930	21.600	-	25.200	106	22.000	4	6,400	88	23.630	18	28.380	12	50,150
SK6-29NZ	33.390	29.213	30.870	25.600	-	29.134	121	26.000	4	6,300	104	27.630	18	32.250	15	53,100
SK6-33NZ	37.320	33.150	34.800	29.133	-	33.070	148	29.667	3	8,520	89	31.500	18	36.250	18	57,400
SK6-37NZ	41.260	37.090	38.740	33.133	-	37.007	165	33.667	3	8,420	101	35.500	20	40.130	18	65,000
SK6-43NZ	47.170	43.071	44.650	39.133	-	42.992	188	39.667	3	8,340	119	41.500	24	46.000	18	74,900

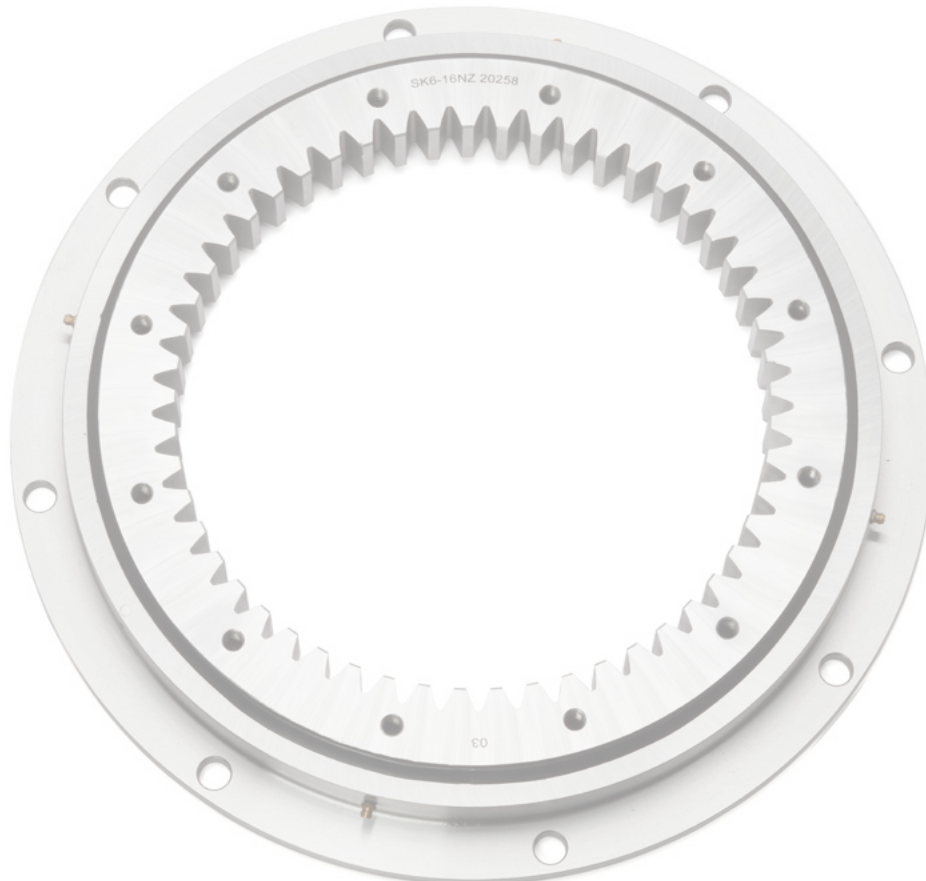

SK6 SERIES - Flanged Slewing Ring

No Gear



SK6 PZ - NO GEAR

- Four-point contact ball
- Flanged cross-section on non-gear rings
- Non-gear
- Internal clearance
- Dimensions up to 60" OD

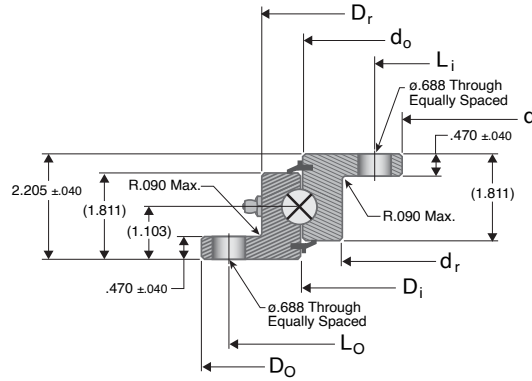

SILVERTHIN PART NUMBER	OVERALL DIMENSION (INCH)						APPROX WEIGHT (LBS)	GEAR DATA (A = 20°)				MOUNTING HOLES				MOMENT RATING (FT-LBS)
	D _o	D _i	D _r	d _i	d _r	d _o		D ₂ (INCH)	GEAR PITCH P _d (INCH)	MAX TOOTH LOAD F ₂ (LBS)	# OF TEETH Z ₂	INNER RING		OUTER RING		
												L _i (INCH)	# HOLES n _i	L _o (INCH)	# HOLES n _o	
SK6-16PZ	20.390	16.220	17.870	11.970	14.490	16.142	58	-	-	-	-	13.130	12	19.250	8	23,300
SK6-22PZ	25.510	21.340	22.990	17.090	19.610	21.260	76	-	-	-	-	18.130	15	24.380	12	33,630
SK6-25PZ	29.450	25.280	26.930	21.030	23.550	25.200	89	-	-	-	-	22.130	18	28.380	12	50,150
SK6-29PZ	33.390	29.212	30.870	24.970	27.490	29.134	104	-	-	-	-	26.130	18	32.250	15	53,100
SK6-33PZ	37.320	33.150	34.800	28.900	31.420	33.070	118	-	-	-	-	30.000	18	36.250	18	57,400
SK6-37PZ	41.260	37.090	38.740	32.840	35.360	37.010	132	-	-	-	-	34.000	20	40.130	18	65,000
SK6-43PZ	47.170	43.000	44.650	38.750	41.270	42.913	153	-	-	-	-	39.880	24	46.000	18	74,900

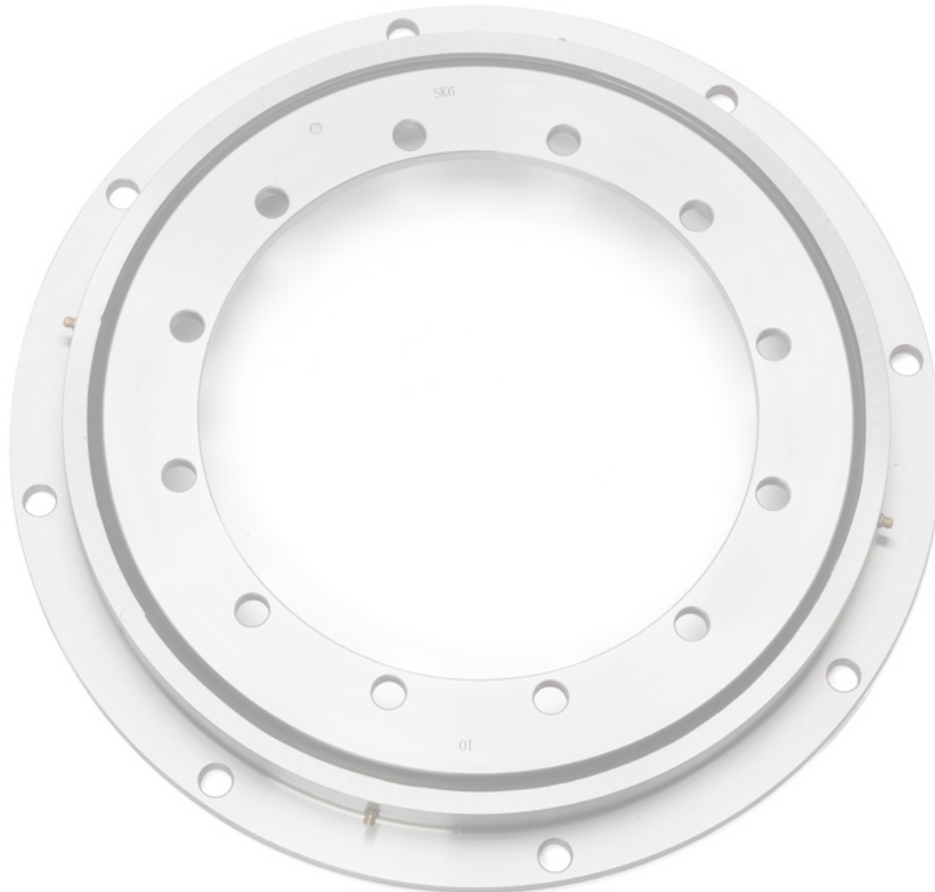

SK6 SERIES - Flanged Slewing Ring

External Gear Slewing Ring



SK6 EZ - EXTERNAL GEAR

- Four-point contact ball
- Flanged cross-section on non-gearred rings
- External gear, AGMA 8 quality
- Internal clearance
- Dimensions up to 60" OD

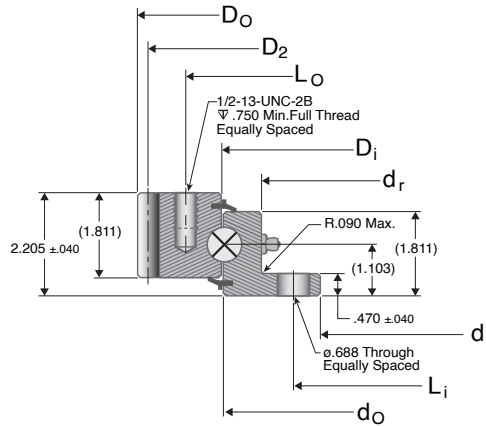

LOAD CONDITION		
MOMENT	THRUST	RADIAL
141,000 ft-lbs to 180,000 ft-lb	175,000 ft-lbs to 223,000 ft-lbs	35,000 lbs to 45,000 lbs

SILVERTHIN PART NUMBER	OVERALL DIMENSION (INCH)						APPROX WEIGHT (LBS)	GEAR DATA (A = 20°)				MOUNTING HOLES				MOMENT RATING (FT-LBS)
	D _o	D _i	D _r	d _i	d _r	d _o		D ₂ (INCH)	GEAR PITCH P _d (INCH)	MAX TOOTH LOAD F ₂ (LBS)	# OF TEETH Z ₂	INNER RING		OUTER RING		
												L _i (INCH)	# HOLES n _i	L _o (INCH)	# HOLES n _o	
SK6-16EZ	19.900	16.220	-	11.970	14.490	16.142	72	19.500	4	5,560	78	13.130	12	18.000	8	23,300
SK6-22EZ	25.150	21.340	-	17.090	19.610	21.260	96	24.750	4	5,650	99	18.130	15	23.250	12	33,630
SK6-25EZ	29.150	25.280	-	21.030	23.550	25.200	115	28.750	4	5,700	115	22.130	18	27.250	15	50,150
SK6-29EZ	32.900	29.220	-	24.970	27.490	29.134	128	32.500	4	5,740	130	26.130	18	31.000	18	53,100
SK6-33EZ	37.200	33.150	-	28.900	31.420	33.070	152	36.667	3	7,580	110	30.000	18	35.000	18	57,400
SK6-37EZ	41.200	37.090	-	32.840	35.360	37.008	172	40.667	3	7,620	122	34.000	20	38.879	18	65,000
SK6-43EZ	46.867	42.992	-	38.750	41.270	42.193	189	46.333	3	7,680	139	39.880	24	44.750	20	74,900



NOTE: The load curves in this section reflect a generic curve for both the STO and STE Series Slewing Ring bearings. The load capacities for the STO Series is actually slightly greater than is shown in the curves in this section. As noted earlier in the Service Factor section of this catalog, if the actual loading, adjusted with an applicable service factor, falls near or below the appropriate curve, please contact Silverthin™ Engineering for a more precise curve.

ST Series

- A. STO-143
- B. STO-122

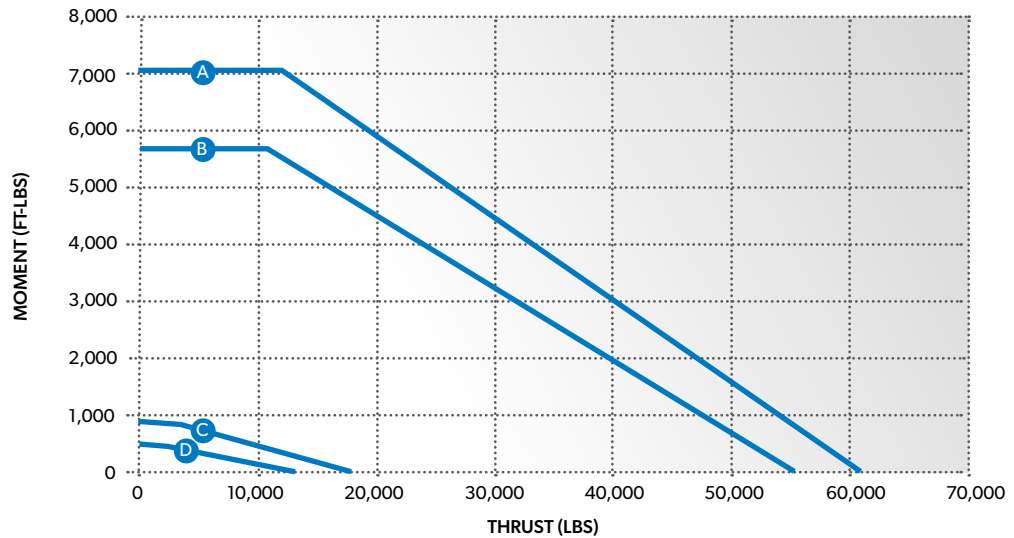

- C. STO-065
- D. STO-050

- E. STO/STE-324X
- F. STO/STE-324T
- G. STO/STE-265X
- H. STO/STE-265
- I. STO/STE-210X
- J. STO/STE-210
- K. STO/STE-170
- L. STO/STE-145X
- M. STO/STE-145

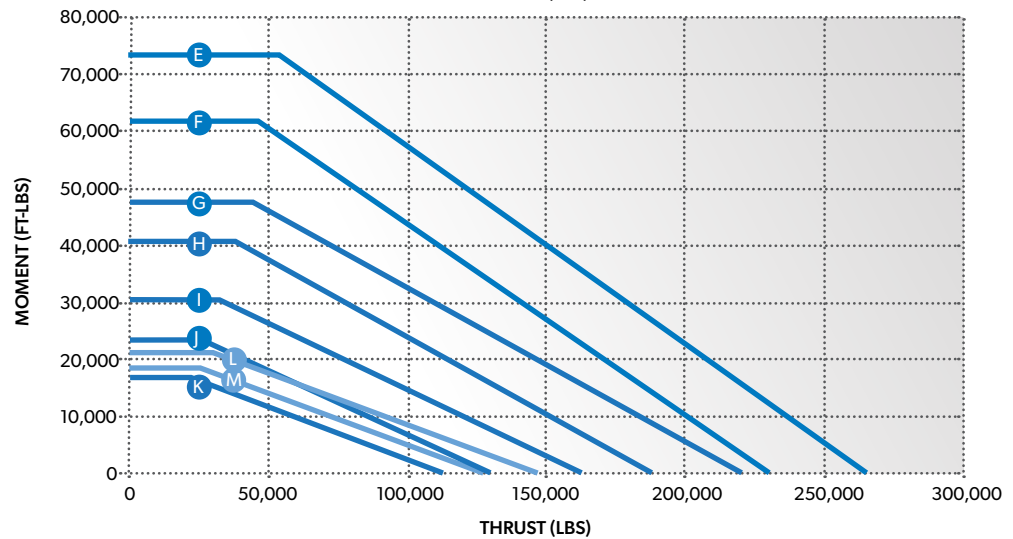

- N. STE-870

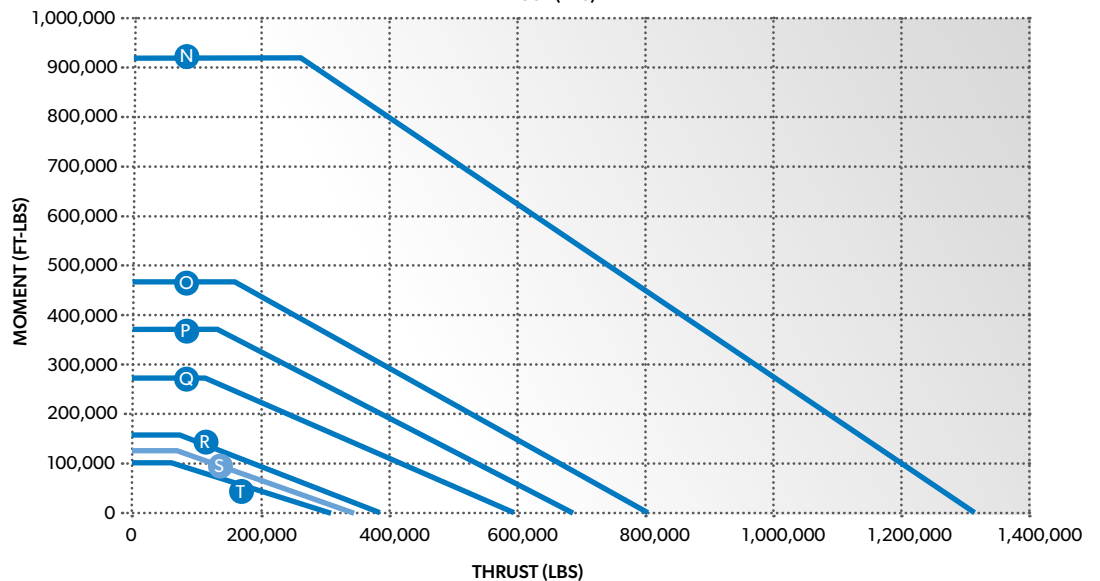

- O. STE-730
- P. STE-705
- Q. STE-590
- R. STE-540
- S. STE-470
- T. STE-415

NOTE: As noted earlier in the Service Factor section of this catalog, if the actual loading, adjusted with an applicable service factor, falls near or below the appropriate curve, please contact Silverthin™ Engineering for a more precise curve.

SK6 Series

- A. SK6-43
- B. SK6-37
- C. SK6-33
- D. SK6-29
- E. SK6-25

- F. SK6-22
- G. SK6-16

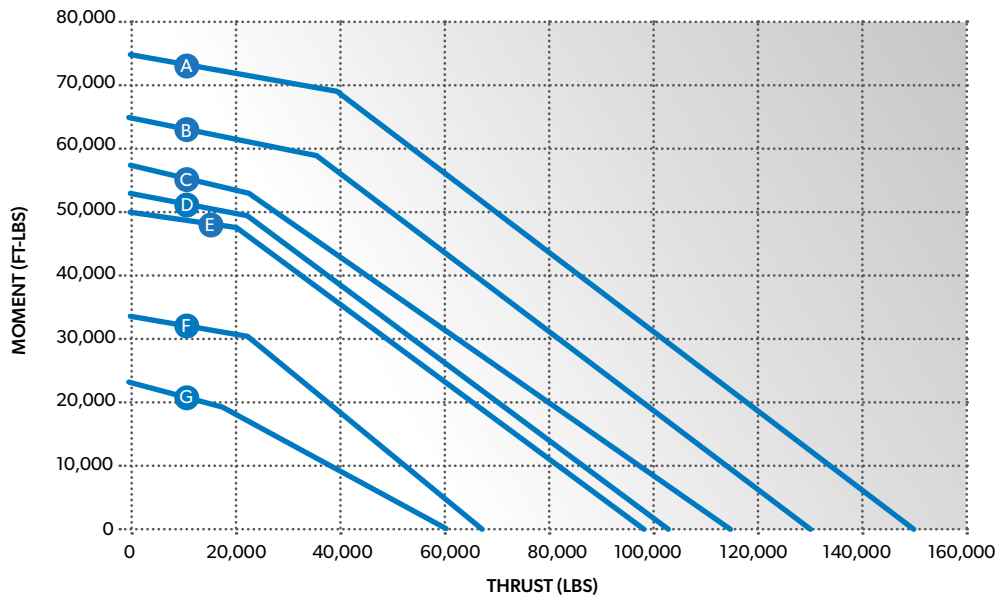

Silverthin is pleased to offer standard, high quality mating pinions from stock for our ST and SK series slewing ring bearings. These pinions are made of AISI 4140 steel and are hardened to have a surface hardness of 55-60 HRC. See below for dimensional data.

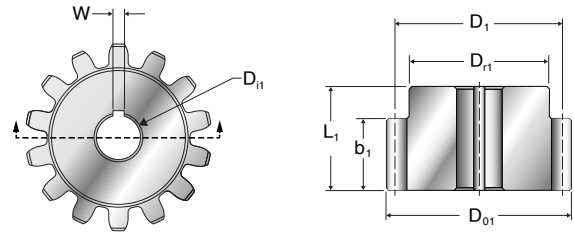

Mating Pinions for SK6 Series Slewing Rings

PINION PART NUMBER	BEARING PART NUMBER	GEAR DATA (A = 20°)				OUTLINE DIMENSIONS						APPROX WEIGHT (LBS)
		TOOTH FORM	TEETH Z ₁	P _d (IN)	b ₁ (INCH)	L ₁ (INCH)	D ₁ (INCH)	D _{o1} (INCH)	D _{r1} (INCH)	D _{i1} (INCH)	w (INCH)	
SP1629-14	SK6-16 THRU SK6-29	SD	14	4	2	2.88	3.5	3.9	2.88	1	1/4	6.4
SP1629-17	SK6-16 THRU SK6-29	SD	17	4	2	2.88	4.25	4.65	3.63	1	1/4	10
SP3343-14	SK6-33 THRU SK6-43	SD	14	3	2	2.88	4.667	5.2	3.88	1.25	5/16	11.4
SP3343-17	SK6-33 THRU SK6-43	SD	17	3	2	2.88	5.667	6.2	4.88	1.25	5/16	18.3
TOLERANCES				REF.	+/-0.015	+/-0.015	REF.	+0.000/-0.010	REF.	+0.002/-0.000		

Mating Pinions for STE Series Slewing Rings

PINION PART NUMBER	BEARING PART NUMBER	GEAR DATA (A = 20°)				OUTLINE DIMENSIONS						APPROX WEIGHT (LBS)
		TOOTH FORM	TEETH Z ₁	P _d (IN)	b ₁ (INCH)	L ₁ (INCH)	D ₁ (INCH)	D _{o1} (INCH)	D _{r1} (INCH)	D _{i1} (INCH)	w (INCH)	
SP145324-14	STE-145 THRU STE-324	FS	14	5/7	2.25	2.88	2.8	3.086	2.206	1	1/4	3.9
SP145324-17	STE-145 THRU STE-324	FS	17	5/7	2.25	2.88	3.4	3.686	2.806	1	1/4	6.6
SP415540-14	STE-415 THRU STE-540	SD	14	4	2	2.88	3.5	3.9	2.88	1	1/4	6.4
SP415540-17	STE-415 THRU STE-540	SD	17	4	2	2.88	4.25	4.65	3.63	1	1/4	10
SP590705-14	STE-590 THRU STE-705	SD	14	3	2	2.88	4.667	5.2	3.88	1.25	5/16	11.4
SP590705-17	STE-590 THRU STE-705	SD	17	3	2	2.88	5.667	6.2	4.88	1.25	5/16	18.3
SP870-17	STE-870	SD	17	2.5	4.3	5.825	6.8	7.44	5.51	2.500	5/8	46.2
TOLERANCES				REF.	+/-0.015	+/-0.015	REF.	+0.000/-0.010	REF.	+0.002/-0.000		



Pinion/Gear Backlash

Backlash, sometimes referred to as play, is the amount of clearance between mating gears. (See Figure Below). For our purposes, the backlash would be between the slewing ring gear and mating pinion. This feature is often controlled by the center distance between the slewing ring and pinion, which can be either fixed or adjustable depending on the demands of the application. See typical backlash ranges table.

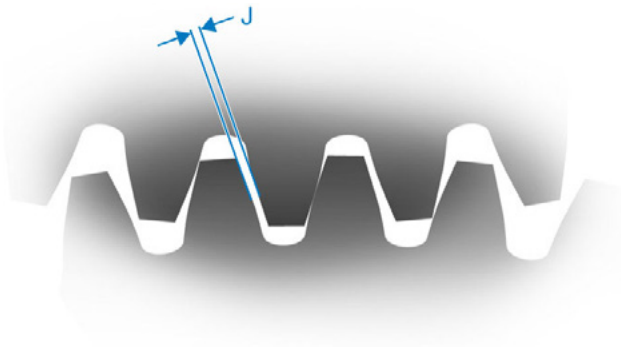

TYPICAL BACKLASH RANGES						
GEAR PITCH DIA D ² (IN)	MIN BACKLASH J (IN)	1.5	1.75	2	2.5	3,4,5
20	0.014	0.029	0.027	0.025	0.023	0.022
30	0.015	0.030	0.028	0.026	0.024	0.023
40	0.016	0.031	0.029	0.027	0.025	0.024
60	0.018	0.033	0.031	0.029	0.027	0.026
80	0.020	0.035	0.033	0.031	0.029	0.028
100	0.022	0.037	0.035	0.033	0.03	0.030
120	0.024	0.039	0.037	0.035	0.033	0.032

Custom Slewing Ring Bearing Options

In addition to our standard slewing ring configurations Silverthin™ offers a wide range of custom options for specialty applications. Custom slewing rings can be modified versions of standard slewing ring bearings, or completely custom. Customizations include but are not limited to:

- Special overall dimensions and tolerances (ID, OD, Widths, Offsets, Special Cross Sections)
- Special internal geometry optimization (increased load capacity, increased precision and runouts).
- Special internal fit (preload or clearance).
- Lube holes and grease fittings (additions, subtractions, locations (ID, OD, Face mounted, recessed), sizes).
- Special gear geometries, gear precision, gear hardness.
- Special hole patterns, sizes, configurations such as:
 - Locating features for mounting such as pilots, locating pins and holes.
 - Special sealing configurations and materials.
 - Accommodate higher speeds and/or constant rotation. Separator (cage) instead of spacers.
 - Mating pinions in standard and custom offerings.
 - Numerous grease and solid lubricant options available. Standard is NLGI 2 Lithium Base Complex grease.
 - Corrosion Resistance:
 - o Special NTDC coatings for rings, equivalent to 440C corrosion resistance, short lead time.
 - o Extra special NTDC processing and coatings for severe corrosive, coastal or ship-board applications.
 - o Stainless steel rings, balls, lube zerks available.
 - o Black phosphorous

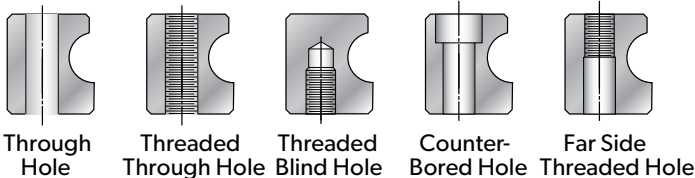

Contact our Engineers

Let us know about your specific your custom bearing or assembly requirements, and one of our engineers will be happy to review your needs and help you find the product that will best fit your specific application requirements.



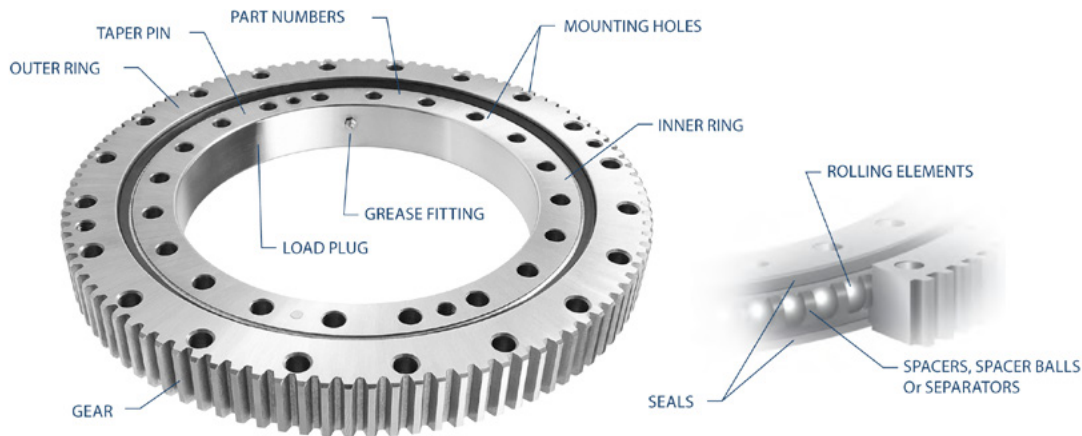

Inner Ring and Outer Ring

The bearings are comprised of two rings, each of which contains a precision raceway that is induction hardened on the surface to a specified depth. Each ring is made from a medium carbon steel forging. Silverthin SK and ST Series bearings have raceways constructed in a four-point contact configuration, with 45° contact angles as standard. Other raceway configurations are available, such as crossed roller and eight-point contact. These other options are often considered in cases where very high loads or special stiffness requirements are needed.

Rolling Elements

Precision rolling elements (specifically hardened chrome alloy steel balls for Silverthin™ SK and ST Series bearings) facilitate relative ring rotation between the inner and outer rings. Rollers as rolling elements are also often used.

Spacers, Spacer Balls & Separators

Spacers, typically made from a plastic material, are commonly used to separate balls to prevent them from rubbing directly against each other. Sometimes spacer balls are utilized instead of spacers. In this case these are balls that are slightly smaller than the load carrying balls, placed between each load carrying ball. Occasionally, application parameters warrant the use of a separator.

Mounting Holes

Mounting holes are generally spaced around the faces of the inner and outer ring along a uniform bolt circle and equal spacing. These holes can be thru holes, tapped holes, blind tapped holes, counter-bored holes, etc. Sometimes bolt circle or spacing requirements need to be customized to meet the demands of a specific application, in which case custom options are available.

In the case of either the standard part numbers listed in this catalog, or other custom versions provided by Silverthin™, the equipment designer, manufacturer, or user is responsible to determine that the mounting design is adequate.

Taper Pin

Secures load plug to the inner or outer ring.

Seals

Seals are provided on each side of the bearing, with their primary functions being grease retention and prevention of some contamination such as dust and debris from entering the bearing. The seals are typically made from an extruded Buna-N rubber strip, and in smaller sizes are a metallic non-contact shield.

Load Plug

Due to the nature of the race hardening process, there is a gap in the race hardness of each race. In that location for the non-gearing ring, or the outer ring for ungeared bearings, a hole is drilled to permit the loading of balls into the final slewing ring assembly. This hole is plugged and secured with a taper pin.

Note that for the ring where a load plug is not present, an 'S' is stamped on the face of that ring at the location of the unhardened gap in the race (also known as the soft spot). Removal of the load plug voids the warranty.

Gear

Slewing ring bearings can be supplied as ungeared, or with gears on either the ID of the inner ring or the OD of the outer ring. Gears are typically a standard stub involute spur gear with backlash provisions and AGMA Q8 quality minimum. Details for each bearing can be found in the enclosed dimensional tables, and drawings are available from Silverthin™ Engineering. Custom gear configurations are also available

Grease Fitting

At least one grease fitting is included in one of the rings. The quantity may increase with the diameter of the bearing. For bearings with gears, the grease fitting(s) are located on either the ID or OD of the ungeared ring. For ungeared bearings, Silverthin™ ST and SK Series slewing rings come equipped to accommodate grease fittings on either the inner or outer ring. Custom quantities, locations and configurations for grease fittings are available.

Part Numbers

Part numbers and serial numbers are etched on one of the faces of the bearing.



To determine if a Silverthin™ Slewing Ring bearing is appropriate for an application, a SERVICE FACTOR is applied. Refer to the table below for a guide to the service factor to apply to your application. The load rating curves shown in this catalog are approximate and represent an application service factor of 1.00. To determine the required bearing rating, multiply the applicable service factor by the applied loads on the bearing, and compare the resultant loads to the load rating curves.

Class of Service	Typical Considerations	Application Examples	Minimum Service Factor
LIGHT	Well defined loading	Tire mounted light duty construction	1.00
	Loading well below capacity	Light duty index table	1.00
	Rotation slow, < 10% of time and intermittent	Light duty industrial manipulator / robot	1.00
		Light duty hand operated mechanism	1.00
		Light duty medical devices	1.00
		Light duty aerial platforms	1.00
		Welding positioners	1.00
		Rotating signs / displays	1.00
MEDIUM	Well defined loading	Track mounted light duty construction	1.00
	Loading near or below capacity	Scrap yard construction	1.00
	Rotation slow, < 30% of time and intermittent	Medium duty industrial manipulator / robot	1.10
		Conveyors	1.25
		Rotary tables	1.25
		Capstans and turnstiles	1.10
Wastewater treatment	1.10		
HEAVY	Loading not well defined	Forestry handling equipment	1.50
	Loading beyond machine capacity	Heavy duty index tables and turntables	1.50
	Shock loading can occur	Excavators	1.50

If you require any assistance in determining an applicable service factor, or would like a more detailed load rating curve (recommended if your service factor adjusted applied loads fall close to, or beyond, the load rating curves shown in this catalog), please contact Silverthin™ Engineering for assistance. Please note that the equipment designer is responsible for determining the correct service factor, often validated by testing.

Typical Application

“Typical application” of Silverthin™ Slewing Ring Bearings will exhibit the conditions listed below. Special consideration must be given to bearing selection and features whenever the application conditions differ from those considered “typical”.

Those typical application conditions are:

- Vertical axis of rotation. Essentially, the bearing mounted “flat”.
- Compressive thrust and moment loads being predominant compared to tension loading.
- Radial load limited to less than 10% of the thrust load.
- For single row bearings, intermittent rotation (not continuous) should not exceed a pitch-line velocity of 500 feet/minute.
- Operating temperature between -40°F to +140°F.
- Mounting surface geometry and installation procedures to assure roundness and flatness of both races. An example approach would be to apply a centered thrust load while tightening the bolts using the alternating star pattern method.
- Periodic checking of mounting bolts to verify proper tension is provided for.
- Periodic lubrication is provided for.

Load Capability

Silverthin Slewing Ring Bearings are designed to accommodate significant radial, thrust and moment loads as shown below:

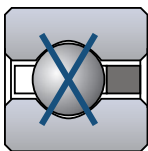
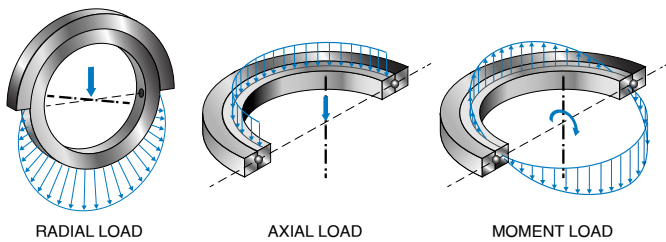

This is accomplished in most cases by the unique four point contact raceway geometry, which is similar in concept to Silverthin™ Type X Thin Section bearings. This allows a single bearing to accommodate all three loading scenarios noted above, either individually or a combination thereof.

Speed

Silverthin Slewing Ring Bearings are used most commonly where rotation is slow, oscillating, and/or intermittent. Maximum speed is recommended not to exceed 500 feet/minute measured at the pitch diameter of the bearing. For constant rotation use and speed limitation calculations, please contact Silverthin Engineering.

Accuracy

Silverthin slewing ring bearings are not typically provided with overall dimensional tolerances in the catalog, however these are available upon request. Some slewing ring applications require a higher degree of accuracy, and the following options are available. Please contact Silverthin Engineering to discuss your requirements:

- Preload versus clearance
- Increased runout or dimensional accuracy
- Locating features such as pins or pilots
- Increased gear accuracy

Environment

Silverthin Slewing Ring Bearings are often used outdoors where exposure to moisture and significant contamination is possible. Normal temperature ranges -40F to +140F (-40C to +60C) are standard. For harsher environments where corrosion resistance is required or desirable, Silverthin offers Nodular Thin Dense Chrome coating options. Some environments where this should be considered would be for coastal and ocean-going vessel applications. Please consult Silverthin Engineering for assistance.

Mounting – Tension versus Compression

As mentioned earlier, it is best to mount the bearings in “compression” as shown below. This ensures that the load is carried by the balls, which is represented in the load curve provided. Tension mounting has significantly less capacity, as then the bolt strength becomes the primary consideration for capacity.

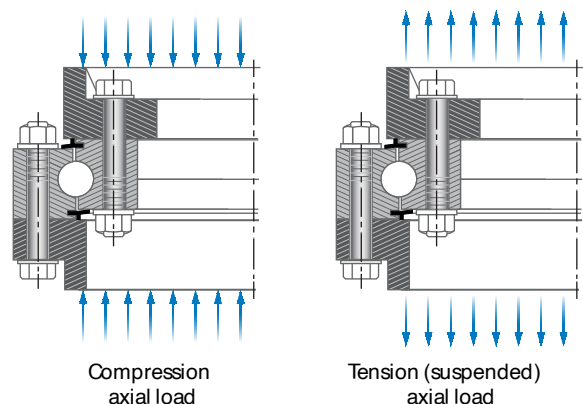

Mounting

Mounting surfaces need to be machined accurately for proper function of the bearing. Where standard bolt patterns cannot be accommodated, contact Silverthin Engineering for alternative options. Consideration must be given to mounting in tension or compression. In tension, BOLT strength becomes the limiting load consideration, the load curve no longer applies, and special considerations must be made. See additional guidelines in the section below.

Minimum Mounting Structure Guidelines

Generally, this rule of thumb will provide adequate structural integrity.

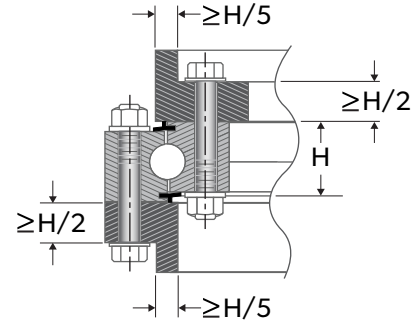

Flatness & Mounting Surface Dish (Mounting Surface)

Flatness of the bearing mounting surface is critical to optimal performance. Frequently mounting structures are welded or worked in a way to induce stress into the structure. These stresses must be relieved, following which the bearing mounting surface must be machined flat. Flatness must be considered:

- Circumferential Direction (δr): The amount of out-of-flatness allowable in the circumferential direction for four-point ball bearings is shown in the figure below. This amount of out-of-flatness must not be exceeded in a span less than 90° , and not more than once in span not more than 180° .
- Allowable Dish or Perpendicularity Deviation in the Radial direction (δp): For four-point contact ball bearing designs, this amount of dish allowable can be approximated using the formula:

$$\delta p \approx 0.001 \times D_w \times P$$

Where: P = radial dim of the mounting structure face (in)
Dw = rolling element diameter (in)

Note that if an application requires greater precision or low rotational torque, it may be necessary to reduce the values of δr and δp . For roller bearings, the amount of flatness allowable is approximately 2/3 of that for an equivalent sized four-point contact ball bearing.

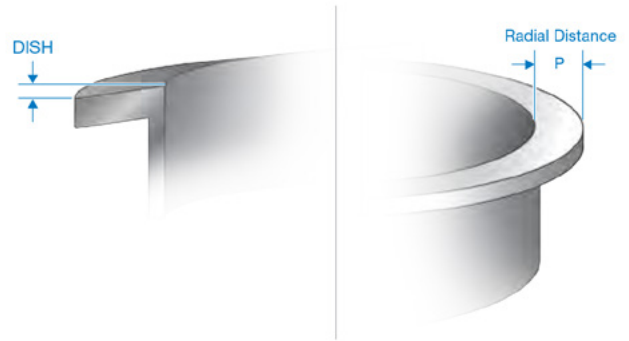

Allowable Deflection vs Raceway Diameter

Must not occur within 90° nor more than once in 180° of circumferential travel

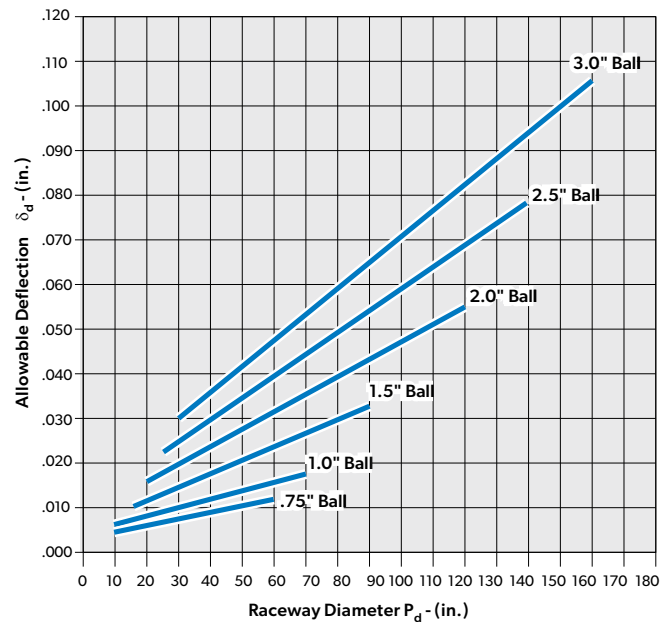

Lubrication

Grease is the most common lubricant used in slewing ring bearings and gear applications. Regular lubrication through provided grease fitting or grease holes is required for proper operation on standard and custom slewing rings. Silverthin bearings can generally be lubricated by the user with an NLGI 2 grease with a Lithium Complex Thickener without special cleaning or compatibility considerations. In many intermittent operating applications, grease is often introduced into the bearing while the bearing is manually rotated to distribute the grease, until it begins to slightly purge from the seals.

Please contact Silverthin Engineering for lubricant recommendations, relubrication intervals and relubrication volumes.

Friction Moment (Rotation Torque)

The Friction Moment can be estimated for a slewing ring bearing using the formula noted below. The resulting values assume that the bearing is mounted according to the guidelines outlined in this catalog.

This estimate only applies when load is applied to an unloaded condition. Also not considered are frictional torque generated by the lubricant, seals and weight of the components. This does however provide a starting point, and with additional experience adjustments can be made in the assembly to accommodate for additional torque.

$$\text{Where: } M_f = \frac{\mu \times (4.4M + F_a D_{pw} + 2.2F_r D_{pw})}{2}$$

- M_f = Bearing starting torque under load (ft-lbs)
- μ = Coefficient of friction (0.006 typically)
- M = Moment load (ft-lbs)
- F_a = Axial load (lbs)
- F_r = Radial load (lbs)
- D_{pw} = Bearing pitch diameter (ft)

Bolts

It is always suggested that bolts be selected with the advice and assistance of a fastening hardware supplier. Bolt quality, pretensioning procedures, and maintenance can vary widely.

The optimal bolting arrangement has a bolt circle in both the inner and outer races with equally spaced fasteners. This results in a more uniform mounting arrangement, yielding the best performance between the bearing and the fasteners. This is not always possible due to mounting structure arrangements, and holes may be shifted accordingly. In these cases testing is recommended to determine actual bolt loads, validate joint configuration and assembly procedure.

As a starting point to determine the approximate load on the heaviest loaded bolt, the following formula can be used. Please note that Silverthin makes no warranty, expressed or implied, regarding bolt adequacy. It is strongly recommended that testing be performed to determine the actual load, as this is the only reliable way to be certain.

$$RB = \left(\frac{12 \times M \times r}{BC \times n} \right) \pm \frac{F_a}{n}$$

Where:

- RB = Total load on heaviest loaded bolt (lbs)
- M = Moment load (ft-lbs)
- R = Rigidity factor. Use 3 for bearings and support structures of average stiffness
- F_a = Axial load (lbs)
 - If F_a is in tension use +
 - If F_a is in compression use -
 - Refer to section "Mounting – Tension versus Compression"
- BC = Bolt circle diameter (in)
- n = Total number of equally distributed bolts
- S_f = Bolt factor of Safety. Minimum recommended value = 3. See formula below:

$$S_f = (\text{Bolt Proof Load Rating}) / RB$$

BOLT DIAMETER (INCH)	PROOF LOAD (LBS)
1/2	17,000
5/8	27,100
3/4	40,100
7/8	55,400
1	72,700
1 1/8	91,600
1 1/4	116,300
1 1/2	168,600

Other Bolting Recommendations:

1. Use hexagon head high strength bolts with coarse threads according to SAE J429, Grade 8 or ASTM A490/A490M or ISO 898-1, Grade 10.9 tensioned to 70% of their yield strength.
2. Use hexagon head coarse thread nuts where applicable according to SAE J995, Grade 8 or ASTM A563, Grade DH or ISO 898-2, Class 10.
3. For optimal bolt tension, the ratio of the distance from the bottom of the bolt head to the first thread of engagement should be 3.5 or greater. Testing is required for validation.
4. All mounting bolts in each ring should have equal clamp length.
5. The distance between the head of the bolt and the bolt threads should be at least equal to the bolt body diameter.
6. The length of the thread engagement of the bolt in the mating steel structure should be at least 1.25 times the bolt diameter.
7. Bench tests are recommended to validate that the bolt tensioning method achieves desired results prior to equipment testing.

Securing Bearing to the Mounting Surface

When installing the bearing, it is important to ensure that the bearing is as round as possible. This will optimize load distribution and promote the smoothest operation. The following procedures are recommended as an aid. Use hardened round flat steel washers in accordance with ASTM F436 under the head of the bolt, and also the nut. Lockwashers, and locking compounds on the thread, are not recommended. Install the washers, nuts and bolts in the bearing and supporting structure and hand tighten. Do not distort the bearing in order to install bolts. Apply a moderate centered thrust load to the bearing. Tighten the bolts to the equipment designer's specifications. A common approach is to use a star pattern to tighten the bolts, sequenced as shown in the diagram below. The pattern is usually done in 3 steps at approximately 30%, 80% and 100% of the final bolt torque or tension level specified by the equipment designer.

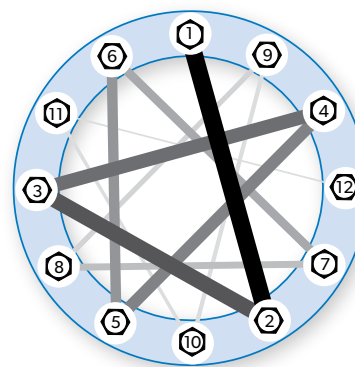

Loss of proper tension can lead to premature bolt failure, failure of the bearing and structure, damage to components, and fatality or injury to anyone in the vicinity. The bolts require frequent inspection for proper tension, which is commonly accomplished by measuring torque of the bolt.

Warning Signs for Bearing Failure

It is good practice to always be aware of the operating condition of your slewing ring bearings. Failure to ensure good condition can result in equipment failure, result in bodily injury or death. It is important that regular maintenance intervals and checks are established and performed to help ensure sound and safe operating conditions. Cease using any slewing ring bearings where the following observations or experiences, or any other suspicious performance or exposure experiences occur. In such cases the bearings should be evaluated for suitability for continued use.

- Visible damage to the bearing such as nicks, gouges, dents, broken seals, cracked rings, damaged gear teeth, damaged holes or any other suspicious visible defects.
- The bearing has extremely rough or increasingly difficult bearing rotation.
- The bearing has limited rotation, seizure, and exhibits vibration or noise that is not typical.
- The bearing is approaching its life expectancy.
- The bearing has been exposed to high vibration.
- The bearing has not been lubricated according to recommendations or shows excessive leakage of lubricant.
- The bearing has been exposed to temperatures in excess of 200F (93C).
- The bearing mating components and hardware exhibit looseness, damage, fracture or is not present or in notable poor condition.



8152 304th Ave. SE
PO Box 5012
Preston, WA 98050
1.425.222.5900

MECHATRONICS CORPORATION is a privately held marketing, distribution, and manufacturing company founded in 1979. Today, the corporation is comprised of five operating groups located near Seattle, WA.

NATIONAL PRECISION

Bearing and Motion Solutions

National Precision distributes bearings to the Aerospace, Medical, Defense, and Industrial markets.

www.nationalprecision.com
Tel: 800-426-8038



MECHATRONICS FAN GROUP

Mechatronics Fan Group manufactures AC, DC & EC cooling fans, blowers and accessories for the Electronic, Food Handling, Medical and HVAC industries.

www.mechatronics.com
Tel: 800-453-4569



SILVERTHIN

Thin, Slewing & Custom Bearing Mfg

Silverthin manufactures thin section ball bearings, slewing ring bearings and custom bearings for Industrial and Defense applications.

www.silverthin.com
Tel: 866-294-5841



MECHCONNECT

Custom Harness & Cable Assembly

MechConnect manufactures cable assemblies, complex wire harnesses, and box builds for Aerospace, Medical, Industrial, Electronic, and Food Service industries.

www.mechconnect.com
Tel: 425-441-1237



K&E AERO TOOLS

Bearing Installation, Test & Removal

K&E AERO TOOLS is a USA manufacturer of bearing installation/removal tools, proof load testing and go kits for the Aerospace market.

www.kandetools.com
Tel: 800-426-8038

